

AIR-COOLED INVERTER CHILLER FOR OUTDOOR INSTALLATION**WSAT-XIN 21-171**

Dear Customer,

We congratulate you on choosing this product

For many years Clivet has been offering systems that provide maximum comfort, together with high reliability, efficiency, quality and safety.

The aim of the company is to offer advanced systems, that assure the best comfort, reduce energy consumption and the installation and maintenance cost for the life cycle of the system.

The purpose of this manual is to provide you with information that is useful from reception of the equipment, through installation, operational usage and finally disposal so that this advanced system offers the best solution.

Yours faithfully,

CLIVET Spa

The data contained in this manual is not binding and may be changed by the manufacturer without prior notice.

Reproduction, even in part, is FORBIDDEN © Copyright - CLIVET S.p.A. - Feltre (BL) - Italia

Index of contents

		4
1	Installation quick guide	5
2	General description	6
3	Reception	8
4	Positioning	10
5	Water connections	12
6	Electrical connections	15
7	Start-up	23
8	Control	29
9	Maintenance	40
10	Alarms - Status	45
11	Accessories	47
12	Decommissioning	52
13	Residual risks	53
14	Technical information	54
15	Dimensional drawings	57

Pagina intenzionalmente bianca – Page intentionally left blank

1 Installation quick guide

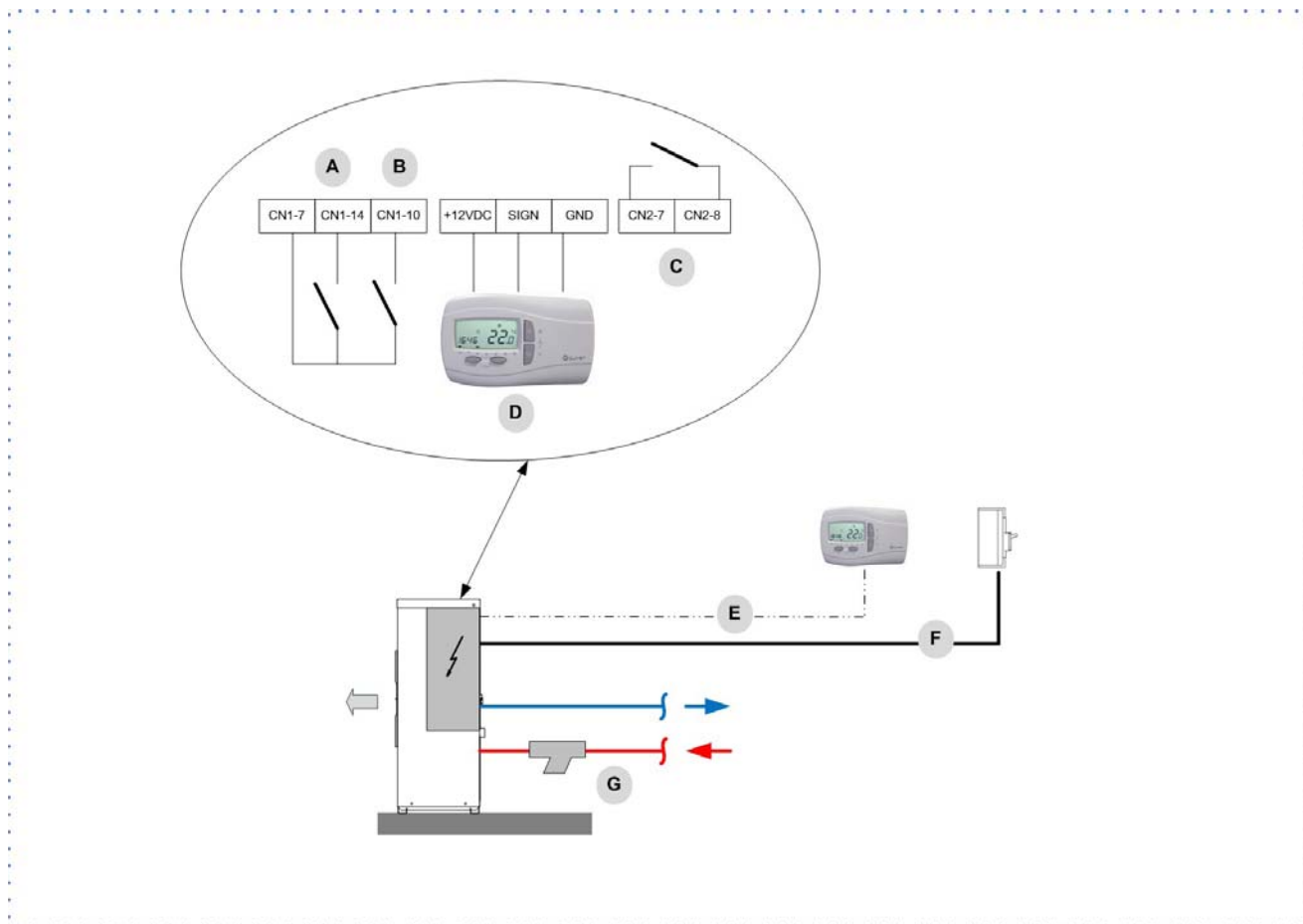

		chapter / page
A	On/Standby	6.7 SA1 = On / Standby remote p. 22
B	SA3: 2° set point	6.6 Connections performer by customer p. 20
C	Remote alarm signal	6.6 Connections performer by customer p. 20
D	Remote control	11.1 RCTX - Remote control p. 47
E	BUS connection, 100m.	11.1 RCTX - Remote control p. 47
F	Power supply	6.4 Power input p. 16
G	Water filter	5.7 Water filter p. 13
	Weight and dimensions	15 Dimensional drawings p. 57

2 General description

2.1 Manual

The manual provides correct unit installation, use and maintenance.

Pay particular attention to:



Warning, identifies particularly important operations or information.



Prohibited operations that must not be carried out, that compromise the operating of the unit or may cause damage to persons or things.

- It is advisable to read it carefully so you will save time during operations.
- Follow the written indications so you will not cause damages to things and injuries people.

2.2 Preliminaries

Only qualified personnel can operate on the unit, as required by the regulation in force.

2.3 Risk situations



The unit has been designed and created to prevent injuries to people.

During designing it is not possible to plane and operate on all risk situation.

Read carefully "Residual risk" section where all situation which may cause damages to things and injuries to people are reported.

Installation, starting, maintenance and repair required specific knowledge; if they are carried out by inexperienced personnel, they may cause damages to things and injuries people.

2.4 Intended use

Use the unit only:

- cooling water or a water and glycol mix for air-conditioning
- Keep to the limits foreseen in the technical schedule and in this manual

The manufacturer accepts no responsibility if the equipment is used for any purpose other than the intended use.

2.5 Installation



The positioning, hydraulic system, refrigerating, electrics and the ducting of the air must be determined by the system designer in accordance with local regulations in force.

Follow local safety regulations.

Verify that the electrical line characteristics are in compliance with data quotes on the unit serial number label.

2.6 Maintenance

Plan periodic inspection and maintenance in order to avoid or reduce repairing costs.



Turn the unit off before any operation.

2.7 Modification



All unit modifications will end the warranty coverage and the manufacturer responsibility.

2.8 Breakdown/Malfuction

Disable the unit immediately in case of breakdown or malfunction.

Contact a certified service agent.

Use original spares parts only.

Using the unit in case of breakdown or malfunction:

- voids the warranty
- it may compromise the safety of the unit
- may increase time and repair costs

2.9 User training



The installer has to train the user on:

- Start-up/shutdown
- Set points change
- Standby mode
- Maintenance
- What to do / what not to do in case of breakdown

2.10 Data update

Continual product improvements may imply manual data changes.

Visit manufacturer web site for updated data.

2.11 Indications for the User



Keep this manual with the wiring diagram in an accessible place for the operator.

Note the unit data label so you can provide them to the assistance centre in case of intervention (see “Unit identification” section).

Provide a unit notebook that allows any interventions carried out on the unit to be noted and tracked making it easier to suitably note the various interventions and aids the search for any breakdowns.

In case of breakdown or malfunction:

- Immediately deactivate the unit
- Contact a service centre authorized by the manufacturer



The installer must train the user, particularly on:

- Start-up/shutdown
- Set points change
- Standby mode
- Maintenance
- What to do / what not to do in case of breakdown

2.12 Unit identification

The serial number label is positioned on the unit and allows to identify all the unit features.

The matriculation plate shows the indications foreseen by the standards, in particular:

- unit type
- serial number (12 characters)
- year of manufacture
- wiring diagram number
- electrical data
- type of refrigerant
- refrigerant charge
- manufacturer logo and address



The matriculation plate must never be removed.



It contains fluorinated greenhouse gases

Type of refrigerant: R410A

2.13 Serial number

It identifies uniquely each unit.

Must be quoted when ordering spare parts.

2.14 Assistance request

Note data from the serial number label and write them in the chart on side, so you will find them easily when needed.

Series
Size
Serial number
Year of manufacture
Electrical wiring diagram

3 Reception

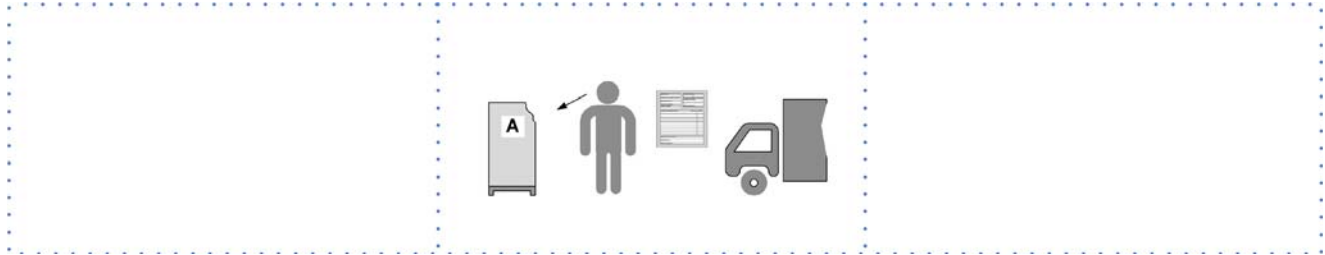

You have to check before accepting the delivery:

- That the unit hasn't been damaged during transport
- That the materials delivered correspond with that indicated on the transport document comparing the data with the identification label positioned on the packaging.

In case of damage or anomaly:

- Write down on the transport document the damage you found and quote this sentence: "Conditional acceptance clear evidence of deficiencies/damages during transport"
- Contact by fax and registered mail with advice of receipt to supplier and the carrier.



Any disputes must be made within 8 days from the date of the delivery. Complaints after this period are invalid.

3.1 Storage

Observe external packaging instructions.

3.2 Handling

1. Verify unit weight and handling equipment lifting capacity.
2. Identify critical points during handling (disconnected routes, flights, steps, doors).
3. Suitably protect the unit to prevent damage.
4. Before starting the handling, make sure that the unit is stable.
5. Start hoisting the unit.
6. Remove screws

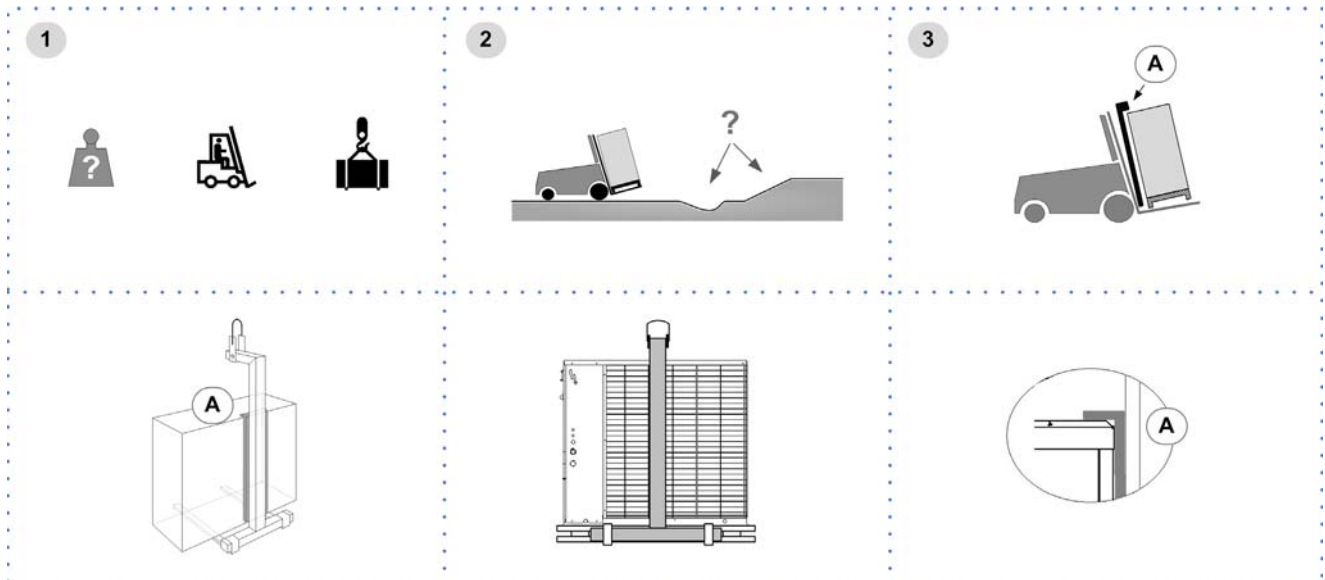

A - Protections

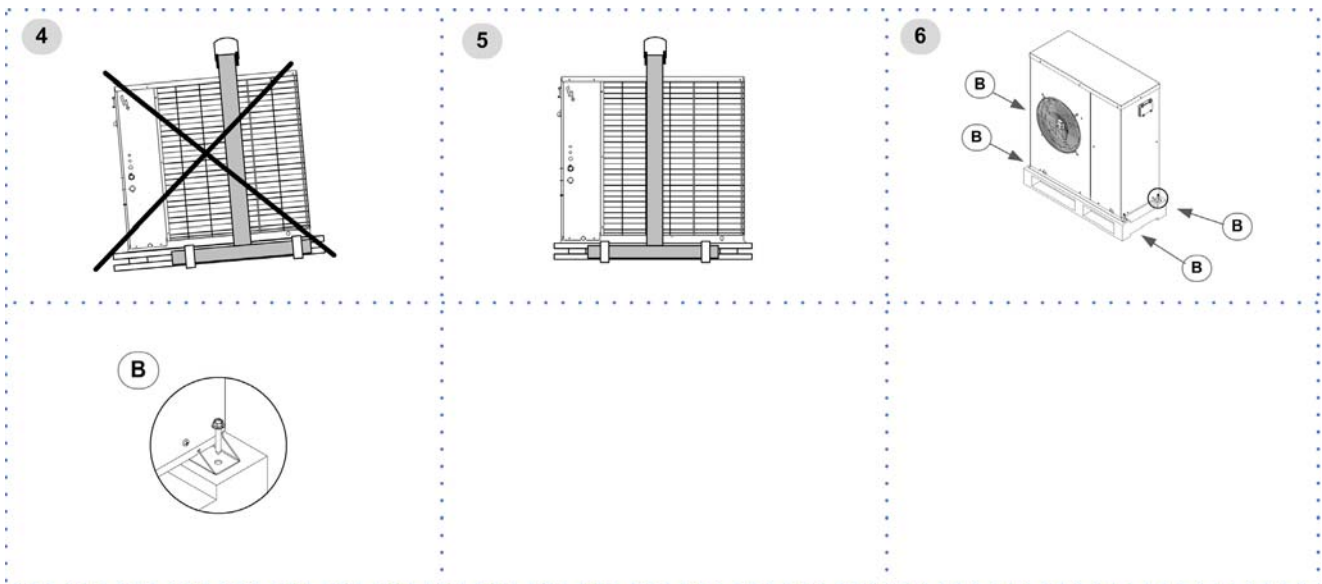

B - Screws

3.3 Packaging removing

Be careful not to damage the unit.

Keep packing material out of children's reach it may be dangerous.

Recycle and dispose of the packaging material in conformity with local regulations.

4 Positioning

During positioning consider these elements:

- Technical spaces requested by the unit
- Electrical connections
- Water connections
- Spaces for air exhaust and intake

4.1 Functional spaces

Functional spaces are designed to:

- guarantee good unit operation
- carry out maintenance operations
- protect authorized operators and exposed people

Respect all functional spaces indicated in the DIMENSIONS section.

Double all functional spaces if two or more unit are aligned.

4.2 Positioning



Units are designed to be installed:

- EXTERNAL
- in fixed positions

Limit vibration transmission:

- use antivibration devices on unit bearing points
- install flexible joints on the hydraulic connections

Choose the installation place according to the following criteria:

- Customer approval
- safe accessible position
- technical spaces requested by the unit
- spaces for the air intake/exhaust
- The device prevents any impurity in the water circuit to dirt the heat exchanger.
- verify unit weight and bearing point capacity
- verify that all bearing points are aligned and leveled
- install the unit raised from the ground
- max. distance allowed by the electrical connections

Prefer places where the unit doesn't disturb the neighbours.



Avoid installations next to bedrooms or windows.

A correct circulation of the air is mandatory to guarantee the good unit operating.



Avoid therefore:

- obstacles to the airflow
- difficulty of exchange
- leaves or other foreign bodies that can obstruct the air coil
- winds that hinder or favour the airflow
- heat or pollution sources close to the unit (chimneys, extractors etc..)
- stratification (cold air that stagnates at the bottom)
- recirculation (expelled air that is sucked in again)
- incorrect positioning, close to very high walls, attics or in angles that could give rise to stratification or recirculation phenomenons

Ignoring the previous indications could:

- reduce energy efficiency
- alarm lockout due to HIGH PRESSURE (in summer) or LOW PRESSURE (in winter)

- A. Keep the min. distances from the pedestrian areas.
- B. Provide windbreaks in locations with strong winds.
- C. Avoid snow accumulations on batteries.
- D. Install the unit lifted from the ground.
- E. Provide a protection.

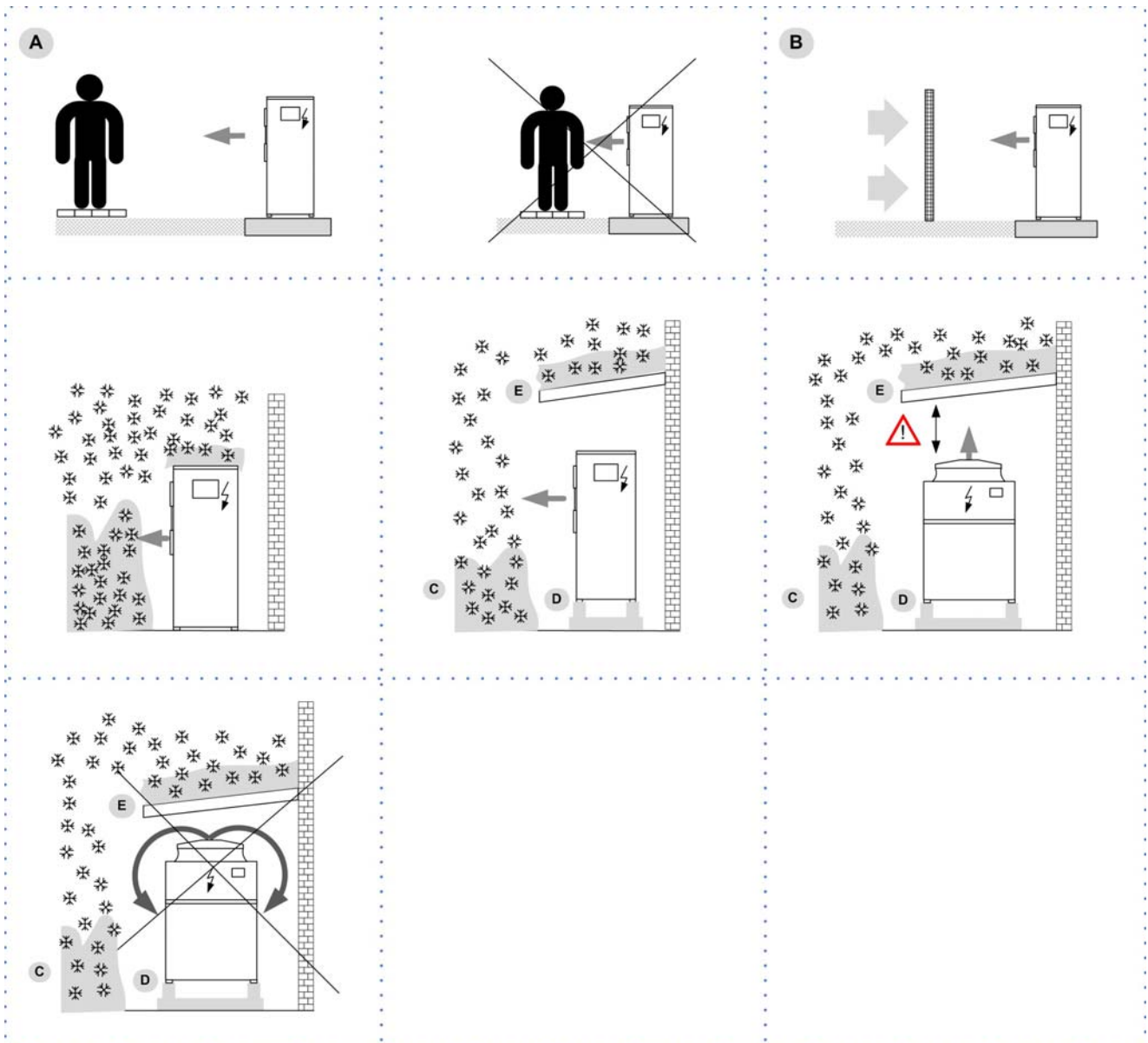

5 Water connections

5.1 Water quality

Water features

- confirming to local regulations
- total hardness < 14°fr
- within the limits indicated by table

The water quality must be checked by qualified personnel.

Water with inadequate characteristics can cause:

- pressure drop increase
- reduces energy efficiency
- increased corrosion potential

Provide a water treatment system if values fall outside the limits.

The warranty does not cover damages caused by limestone formations, deposits and impurities from the water supply and / or failure from failed system clearing to clean system.

Water component for corrosion limit on Copper		
PH	7,5 + 9,0	
SO ₄ ⁻²	< 100	ppm
HCO ₃ ⁻ / SO ₄ ⁻²	> 1	
Total Hardness	4,5 + 8,5	dH
Cl ⁻	< 50	ppm
PO ₄ ³⁻	< 2,0	ppm
NH ₃	< 0,5	ppm
Free Chlorine	< 0,5	ppm
Fe ²⁺	< 0,5	ppm
Mn ²⁺	< 0,05	ppm
CO ₂	< 50	ppm
H ₂ S	< 50	ppb
Temperature	< 65	°C
Oxygen content	< 0,1	ppm

5.2 Risk of freezing

If the unit or the relative water connections are subject to temperatures close to 0°C:

- mix water with glycol, or
- safeguard the pipes with heating cables placed under the insulation, or
- empty the system in cases of long non-use

5.3 Anti-freeze solution

The use of an anti-freeze solution results in an increase in pressure drop.



Make sure that the glycol type utilized is inhibited (not corrosive) and compatible with the water circuit components.



Do not use different glicol mixture (i.e. ethylene with propylene).

5.4 Water flow-rate

The project water-flow must be:

- inside the exchanger operating limits (see the TECHNICAL INFORMATION section)
- guarantee, also with variable system conditions (for example in systems where some circuits are bypassed in particular situations).

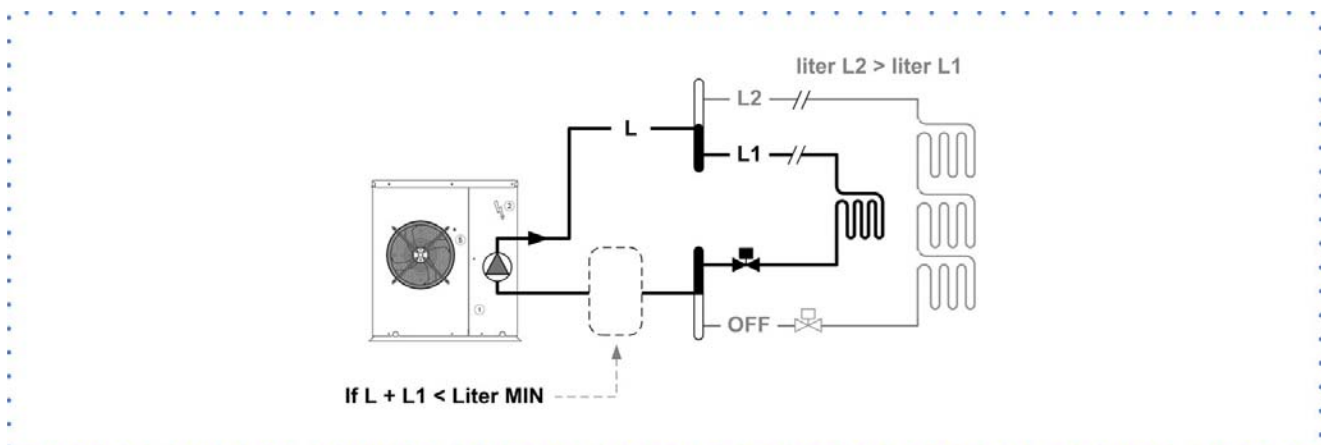

Version: Premium

Size		21	31	41	51	71	81	91	101	121	131	141
Min. installation water contents	litres	17	20	25	33	40	50	53	57	63	68	74

Version: Excellence

Size		21	31	41	51	71	81	91	101	121	131	141	151	161	171
Min. installation water contents	litres	17	20	25	33	40	50	53	57	63	68	87	99	113	117

5.5 Operation sequence

Close all vent valves in the high points of the unit hydraulic circuit

Close all drain valves in the low points of the unit hydraulic circuit:

- Heat exchangers
 - Pumps
 - collectors
 - storage tank
 - free-cooling coil
1. Carefully wash the system with clean water: fill and drain the system several times.
 2. Apply additives to prevent corrosion, fouling, formation of mud and algae.
 3. Fill the plant
 4. Execute leakage test.
 5. Isolate the pipes to avoid heat dispersions and formation of condensate.
 6. Leave various point of service free (wells, vent-holes etc).

Neglecting the washing will lead to several filter cleaning interventions and at worst cases can cause damages to the exchangers and the other parts.

5.6 Recommended connection

The installer must define:

- component type
- position in system

Water input output position:

15 Dimensional drawings p. 57

See adhesive labels on the unit

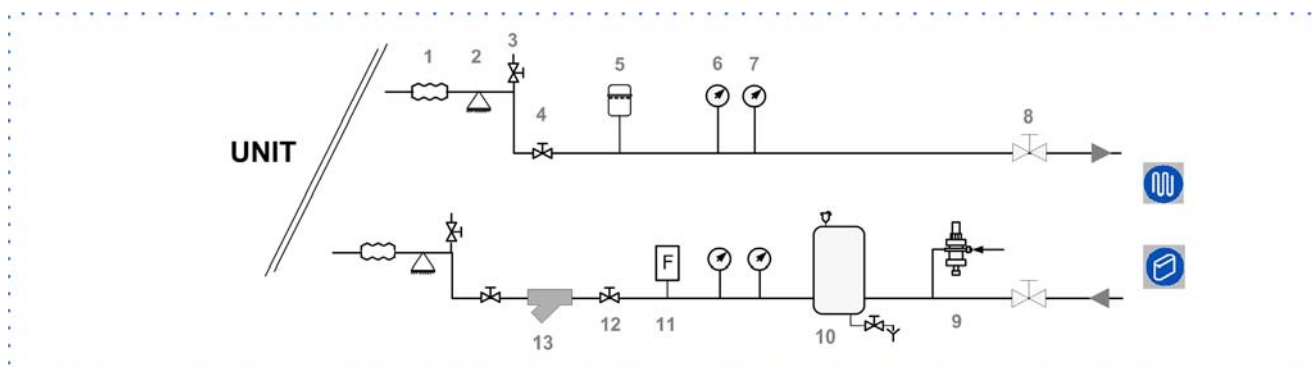

- | | | | |
|---|------------------------------------|----|-----------------------|
| 1 | antivibration joints | 8 | shut-off valve |
| 2 | piping support | 9 | filling valve |
| 3 | exchanger chemical cleaning bypass | 10 | Internal storage tank |
| 4 | shut-off valve | 11 | Flow Switch |
| 5 | expansion vessel | 12 | shut-off valve |
| 6 | pressure gauge | 13 | filter |
| 7 | thermometer | | |

5.7 Water filter

It must be installed immediately in the water input of the unit, in a position that is easily accessible for cleaning.

The filter never should be removed, this operation invalidates the guaranty.

5.8 Flow Switch

The flow switch must be present to ensure shutdown of the unit if water is not circulating.
It has to be installed in a duct rectilinear part, not in proximity of curves that cause turbulences.

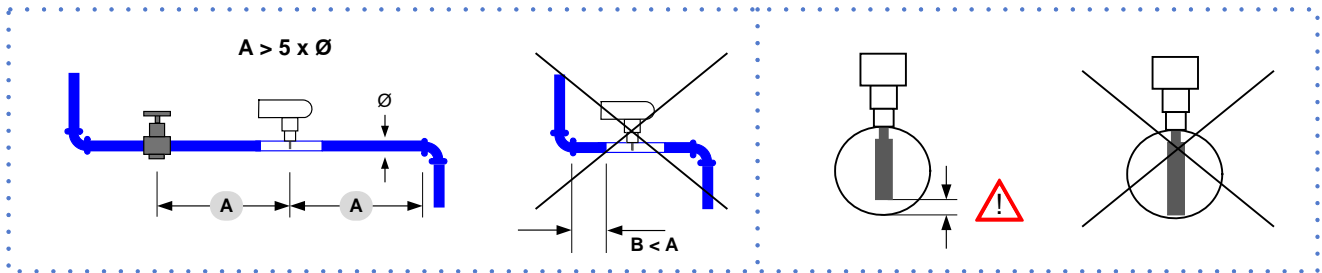

A. minimum distance

6 Electrical connections

The characteristics of the electrical lines must be determined by qualified electrical personnel able to design electrical installations; moreover, the lines must be in conformity with regulations in force.

The protection devices of the unit power line must be able to stop all short circuit current, the value must be determined in accordance with system features.

The power cables and the protection cable section must be defined in accordance with the characteristics of the protections adopted.

All electrical operations should be performed by trained personnel having the necessary qualifications required by the regulations in force and being informed about the risks relevant to these activities.

Operate in compliance with safety regulations in force.

6.1 Electrical data



The serial number label reports the unit specific electrical data, included any electrical accessories.

The electrical data indicated in the technical bulletin and in the manual refer to the standard unit, accessories excluded.

The matriculation plate shows the indications foreseen by the standards, in particular:

- Voltage
- F.L.A.: full load ampere, absorbed current at maximum admitted conditions
- F.L.I.: full load input, full load power input at max. admissible condition
- Electrical wiring diagram Nr.

6.2 Connections

1. Refer to the unit electrical diagram (the number of the diagram is shown on the serial number label).
2. Verify that the electrical supply has characteristics conforming to the data shown on the serial number label.
3. Before starting work, ensure the unit is isolated, unable to be turned on and a safety sign used.
4. Ensure correct earth connection.
5. Ensure cables are suitably protected.
6. Before powering up the unit, make sure that all the protections that were removed during the electrical connection work have been restored.

6.3 Signals / data lines

Do not exceed the maximum power allowed, which varies, according to the type of signal.

Lay the cables far from power cables or cables having a different tension and that are able to emit electromagnetic disturbances.

Do not lay the cable near devices which can generate electromagnetic interferences.

Do not lay the cables parallel to other cables, cable crossings are possible, only if laid at 90°.

Connect the screen to the ground, only if there aren't disturbances.

Guarantee the continuity of the screen during the entire extension of the cable.

Respect impedance, capacity and attenuation indications.

6.4 Power input

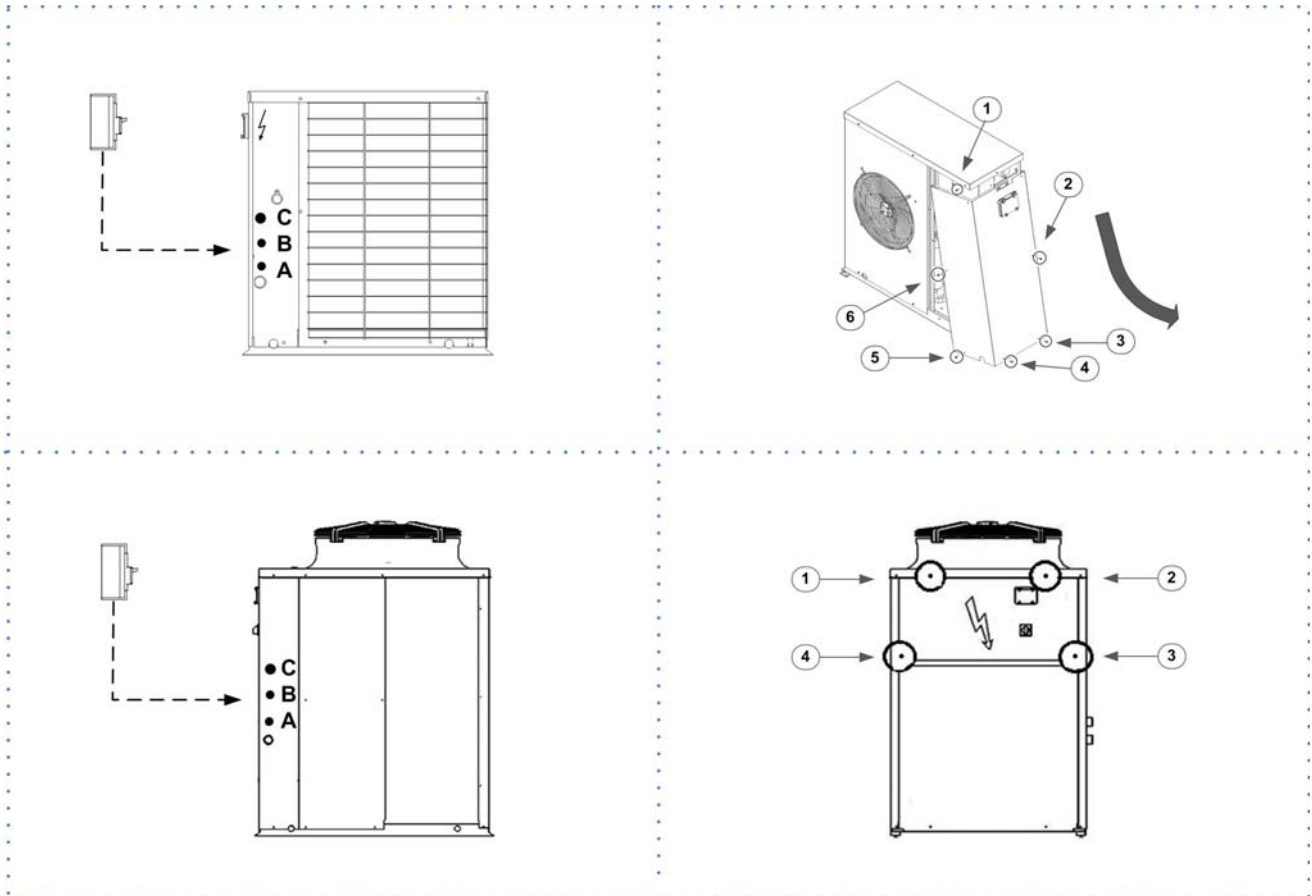

- A Ø mm 22
- B Ø mm 22
- C Ø mm 34

- ⚠ Install the isolator switch near the unit.
- ⚠ Fix the cables: if vacated may be subject to tearing.
- ⊘ The cable must not touch the compressor and the refrigerant piping (they reach high temperatures).

6.5 Electrical panel

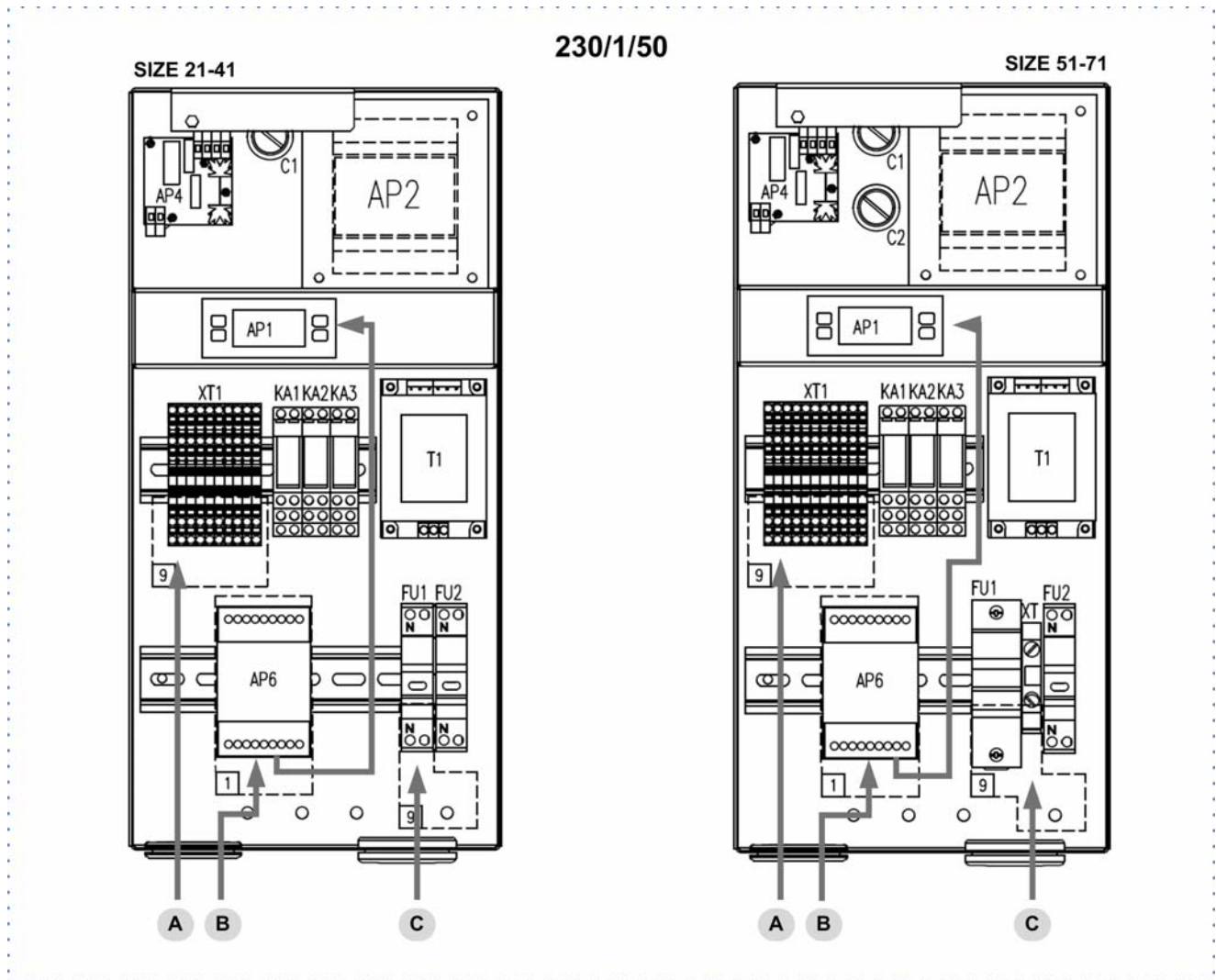

A Signals

B RS485

C Power supply

AP1	Main control module
AP2	Electronic thermostatic management
AP4	Fan control module
AP6	RS 485 module (OPTIONAL)
C1	Fan capacitor
T1	Transformer

FU1	Fuse
FU2	230V aux. circuit fuse
KA1	Inverter alarm auxiliary relay
KA2	Compressor control relay
KA3	Circulation pump control relay
XT1	Terminal block of the customer connections

400/3/50+N

SIZE 51-71

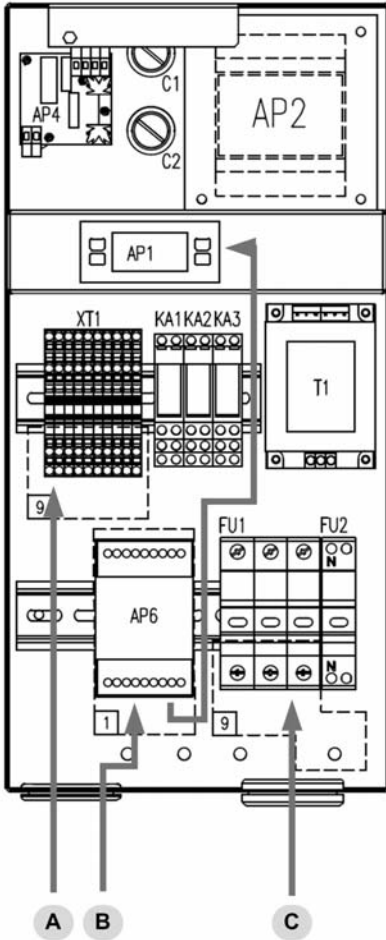

SIZE 81-141

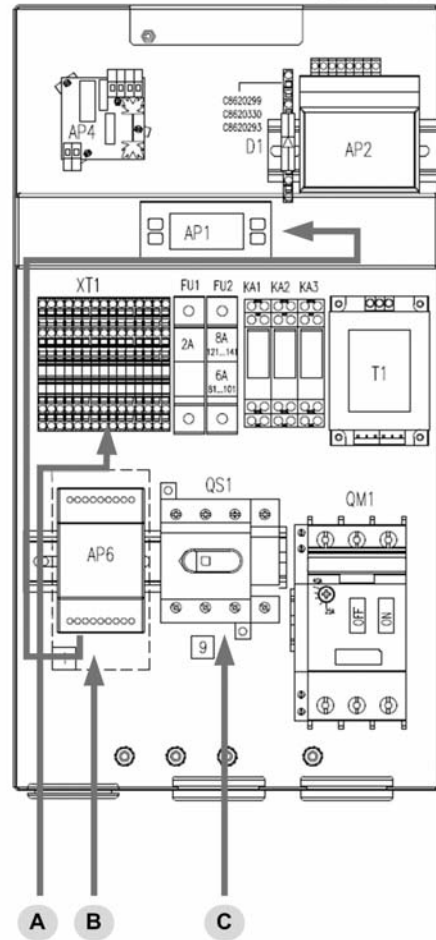

A Signals

B RS485

C Power supply

- AP1 Main control module
- AP2 Electronic thermostatic management
- AP4 Fan control module
- AP6 RS 485 module (OPTIONAL)
- C1 Fan capacitor
- C2 Fan capacitor
- T1 Transformer
- FU1 compressor overload protection and timer Size 51-71
- FU2 230V aux. circuit fuse Size 51-71

- FU1 230V aux. circuit fuse
- FU2 compressor overload protection and timer
- QS1 Main isolator switch
- QM1 Compressor line protection
- KA1 Inverter alarm auxiliary relay
- KA2 Compressor control relay
- KA3 Circulation pump control relay
- XT1 Terminal block of the customer connections

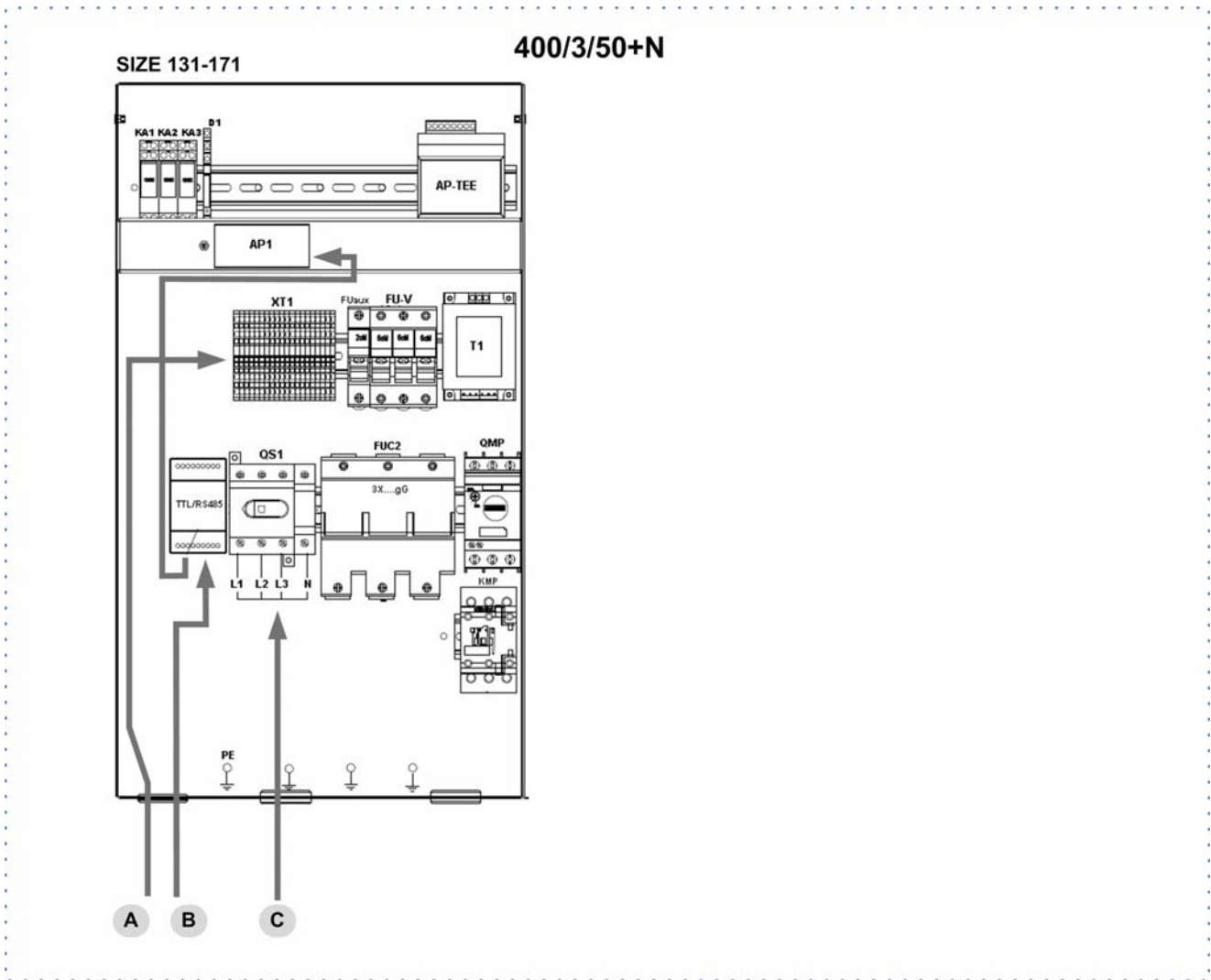

A Signals

B RS485

C Power supply

AP1	Main control module	QS1	Main isolator switch
AP-TEE	Electronic thermostatic management	QMP	Pump motor overload cutout
AP4	Fan control module	KMP	Circulation pump control contactor
TTL-RS485	RS 485 module (OPTIONAL)	KA1	Inverter alarm auxiliary relay
T1	Transformer	KA2	Compressor control relay
FUC2	compressor overload protection and timer	KA3	Circulation pump control relay
FUAux	230V aux. circuit fuse	XT1	Terminal block of the customer connections
FU-V	Fan protection fuse		

6.6 Connections performer by customer

Electrical panel
sizes 21÷71 - 230/1/50

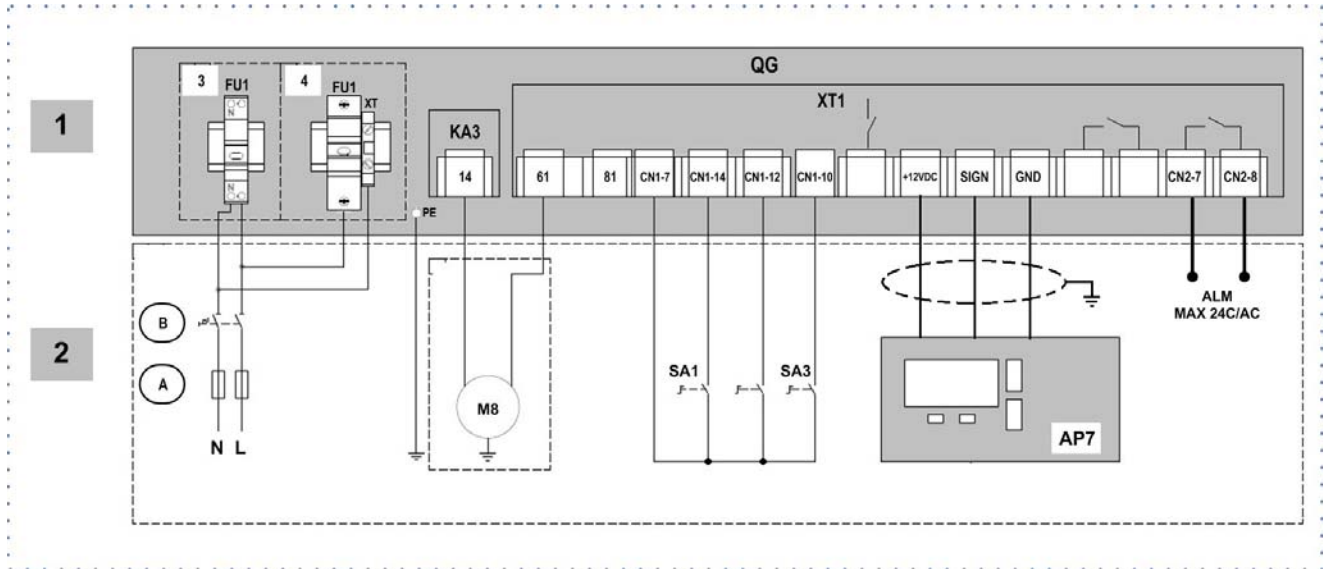

- 1 Unit
- 2 Connections performer by customer
- 3 Only for sizes 21-41
- 4 Only for sizes 51-71



A Fuses
Provided by the customer



B Isolating switch
Provided by the customer

FU1 Fuse

QG Electrical panel

AP7 Room keypad

SA1 On / Standby remote
6.7 SA1 = On / Standby remote p. 22

SA3 Second setpoint enabling
7.10 SA3: 2° set point p. 25

M8 Pump use
Provided by the customer

ALM Cumulative fault signal, max 24v/AC

XT1 Terminal block of the customer connections

Electrical panel
sizes 51÷71 - 400/3/50

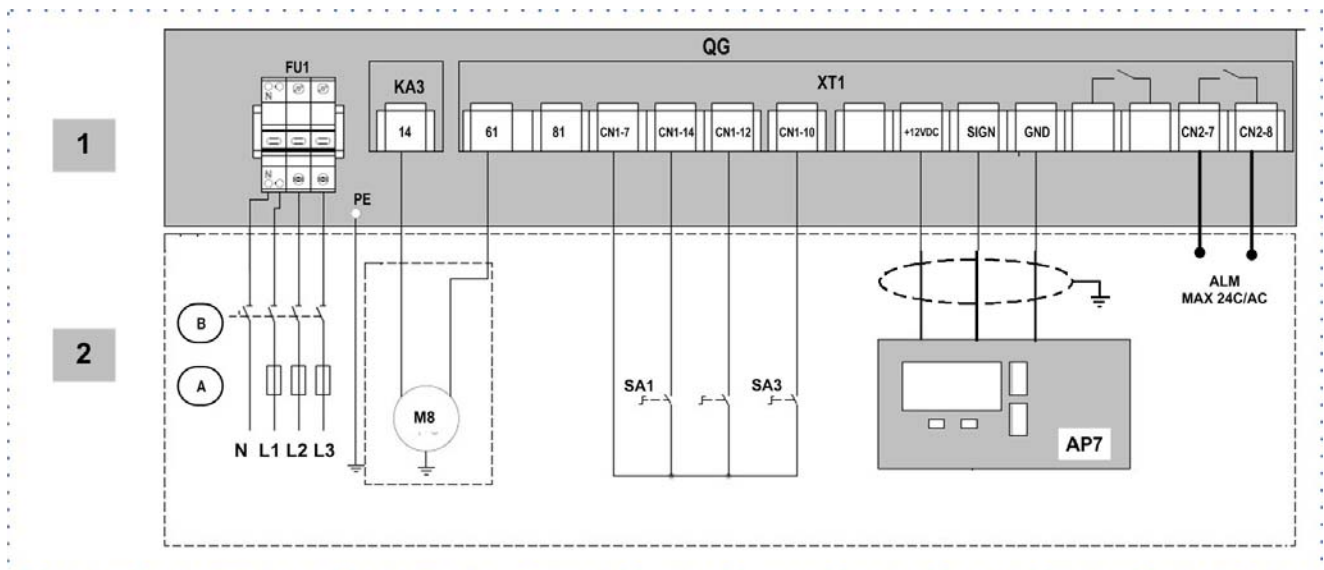

Electrical panel
sizes 81÷141 - 400/3/50

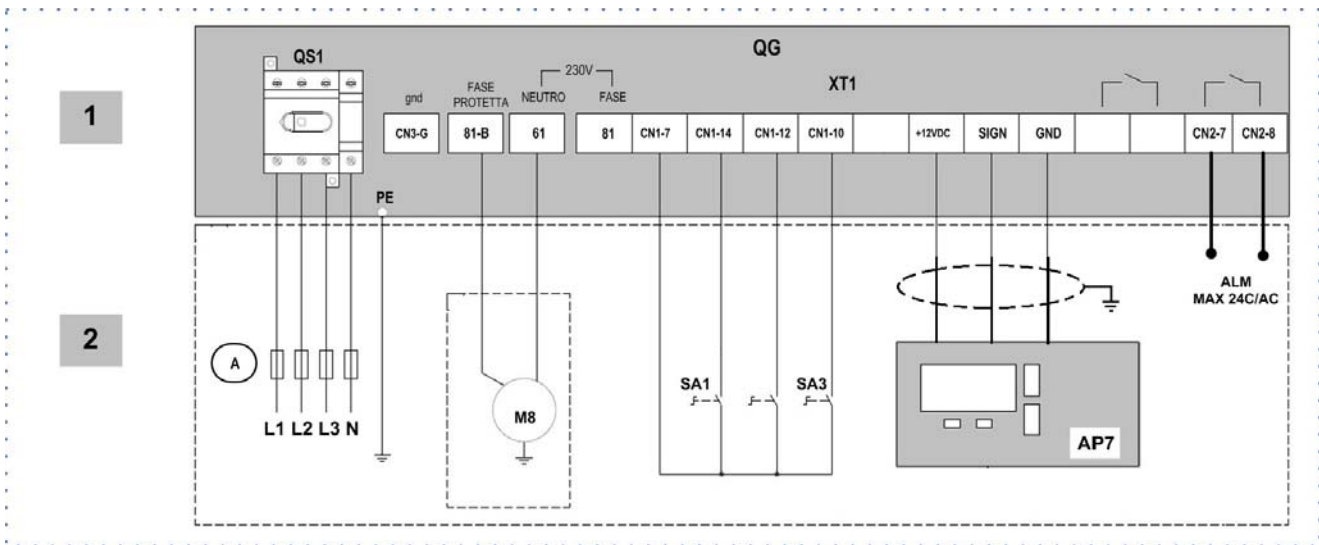

- 1 Unit
- 2 Connections perfer by customer
- A Fuses
Provided by the customer
- QS1 Isolating switch
- QG Electrical panel
- SA1 On / Standby remote

- SA3 Second setpoint enabling
- AP7 Room keypad
- M8 Pump use
Provided by the customer
- ALM Cumulative fault signal,max 24v/AC
- XT1 Terminal block of the customer connections

Version: Excellence
Electrical panel
sizes 131÷171 - 400/3/50

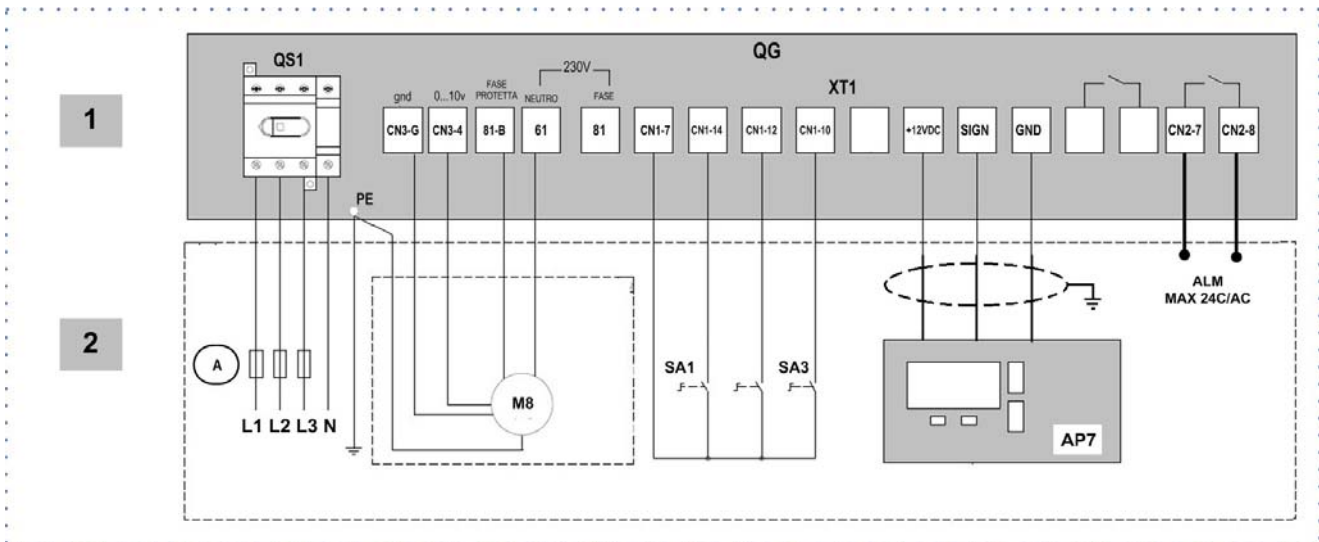

6.7 SA1 = On / Standby remote

Set parameter CL43:

Keys Esc + Set → Menu PAr → Menu CL

CL43	ON/OFF	Standby	Time bands	only DHW
-1	from Menu: Fnc - St	SA1 = remote standby	NO	from Menu: Operating mode
0	from Menu: Fnc - St	from keypad: key DOWN	YES	from Menu: Operating mode

OFF: emergency stop, not active the antifreeze safeties etc.

Standby: assisted stop, are active the antifreeze safeties etc.

6.8 Remote control

For details see:

11 Accessories p. 47

6.9 Serial communication module with RS485 serial converter kit

For details see:

11.2 CMSC2X - Serial communication module with RS485 serial converter kit p. 48

6.10 SA3 Second setpoint enabling switch

For details see:

7.10 SA3: 2° set point p. 25

6.11 Cascade units

For details see:

11.3 KG4UP - Management kit up to 4 units in parallel by the two set point available for each unit p. 49

7 Start-up

7.1 General description

The indicated operations should be done by qualified technician with specific training on the product.

Upon request, the service centres performing the start-up.

The electrical, water connections and the other system works are by the installer.

Agree upon in advance the start-up data with the service centre.

Before checking, please verify the following:

- the unit should be installed properly and in conformity with this manual
- the electrical power supply line should be isolated at the beginning
- the unit isolator is open, locked and equipped with the suitable warning
- make sure no tension is present



After turning off the power, wait at least 5 minutes before accessing to the electrical panel or any other electrical component.



Before accessing check with a multimeter that there are no residual stresses.

7.2 Preliminary checks

For details refer to the different manual sections.

Unit OFF power supply

1. safety access
2. functional spaces
3. air flow: correct return and supply (no bypass, no stratification)
4. structure integrity
5. fans run freely
6. unit on vibration isolators
7. unit input water filter + shut-off valves for cleaning
8. vibration isolators on water connections
9. expansion tank (indicative volume = 5% system content)
10. cleaned system
11. loaded system + possible glycol solution + corrosion inhibitor
12. system under pressure
13. vented system
14. refrigerant circuit visual check
15. earthing connection
16. power supply features
17. electrical connections provided by the customer

7.3 Start-up sequence

For details refer to the different manual sections.

Unit ON power supply

1. compressor crankcase heaters operating at least since 8 hours
2. off-load voltage measure
3. phase sequence check (unit only 400/3/50)
4. unit ON
5. load voltage measure and absorptions
6. check all fan operating
7. measure of return and supply water temperature and flow valuation
8. super-heating and sub-cooling measure and discharge temperature
9. check no anomalous vibrations are present
10. climatic curve personalization
11. set date and time
12. personalise scheduling
13. climatic curve personalization
14. set remote control *
15. complete and available unit documentation

*If present

7.4 Refrigeration circuit

1. Check carefully the refrigerating circuit: the presence of oil stains can mean leakage caused by transportation, movements or other).
2. Verify that the refrigerating circuit is in pressure: Using the unit manometers, if present, or service manometers.
3. Make sure that all the service outlets are closed with proper caps; if caps are not present a leak of refrigerant can be possible.
4. Open the valves of the refrigerant circuit, if there are any.

7.5 Water circuit

1. Before realizing the unit connection make sure that the hydraulic system has been cleaned up and the cleaning water has been drained.
2. Check that the water circuit has been filled and pressurized.
3. Check that the shut-off valves in the circuit are in the "OPEN" position.
4. Check that there isn't air in the circuit, if required, evacuate it using the air bleed valve placed in the system high points.

When using antifreeze solutions:

- make sure the glycol percentage is suitable for the type of use envisaged

Weight of glycol (%)	10	20	30	40
Freezing temperature (°C)	-3.9	-8.9	-15.6	-23.4
Safety temperature (°C)	-1	-4	-10	-19

Modify the following parameters:

SetPoint Cool	key	Set	▶	Menu	SP	▶	Cool					
Min Setpoint Cool tr11<SetPoint Cool	Keys	Esc	+	Set	▶	Menu	PAr	▶	Menu	TR	▶	tr11
Antifreeze alarm setpoint	Keys	Esc	+	Set	▶	Menu	PAr	▶	Menu	AL	▶	AL51
Pump start setpoint for antifreeze	Keys	Esc	+	Set	▶	Menu	PAr	▶	Menu	PI	▶	PI51
Antifreeze Heater Set Point	Keys	Esc	+	Set	▶	Menu	PAr	▶	Menu	Hi	▶	Hi12

(PI51 = Hi12)>AL51

For example: AL51=0°C Hi12=+1°C PI51=+1°C

7.6 Electric Circuit



Verify that the unit is connected to the ground plant.

Check the conductors are tightened as: the vibrations caused by handling and transport might cause these to come loose.

Connect the unit by closing the sectioning device, but leave it on OFF.

Controllare i valori di tensione e frequenza di rete, che devono essere entro i limiti:

- 400/3/50 +/-10%
- 230/1/50 +/-10%

Check and adjust the phase balance as necessary: it must be lower than 2%

Example:

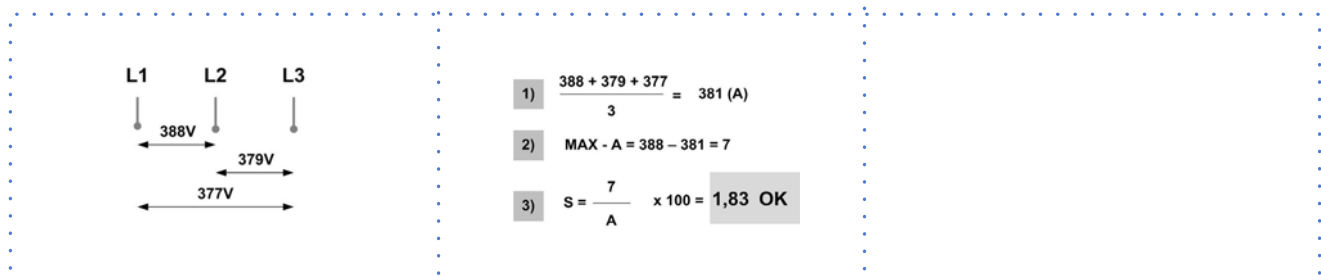

Working outside of these limits can cause irreversible damages and voids the warranty.

7.7 Compressor crankcase heaters

Connect the oil resistances on the compressor crankcase at least 8 hours before the compressor is to be started:

- at the first unit start-up
 - after each prolonged period of inactivity
1. Supply the resistances switching off the unit isolator switch.
 2. To make sure that heaters are working, check the power input.
 3. At start-up the compressor crank-case temperature on the lower side must be higher at least of 10°C than the outside temperature.

⊘ Do not start the compressor with the crankcase oil below operating temperature.

7.8 Voltages

Check that the air and water temperatures are within in the operating limits.

Start-up the unit.

With unit operating in stable conditions, check:

- Voltage
- Total absorption of the unit
- Absorption of the single electric loads

7.9 Remote controls

Check that the remote controls (ON / Standby etc) are connected and, if necessary, enabled with the respective parameters as indicated in the “electrical connections” section.

Check that probes and optional components are connected and enabled with the respective parameters (“electrical connections” section and following pages).

7.10 SA3: 2° set point

Enable SA3

Main menu \boxtimes Par \boxtimes CL \boxtimes CL45 = 22

Example:

Set Cool = 12 °C

tr15 = 1°C

2° set Cool = 13°C

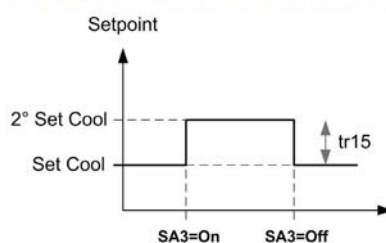

Parameter modification:

Main menu \boxtimes Par \boxtimes Tr \boxtimes Tr15

Tr15 Differential SetCool

7.11 Water set point compensation with ambient temperature

Only with ambient keyboard option.

Function and parameters are the same of paragraph “Water set point compensation with external temperature”

On the ambient keyboard set parameter Cr 30 = 10

It is possible enable ambient compensation OR external compensation, not ambient AND external compensation.

7.12 Water set point compensation with external temperature

It is possible to automatically change the set-point according to the outside temperature.

Keys Esc + Set → Menu dS → dS00

Enable the function:

Par: dS00 set-point compensation of the outside temp.

0 = Disabled

1 = Proportional

2 = Fixed (by step)

With low ext. temperature the refrigerant requirements are reduced.

The internal comfort can also be obtained with a set-point higher than standard.

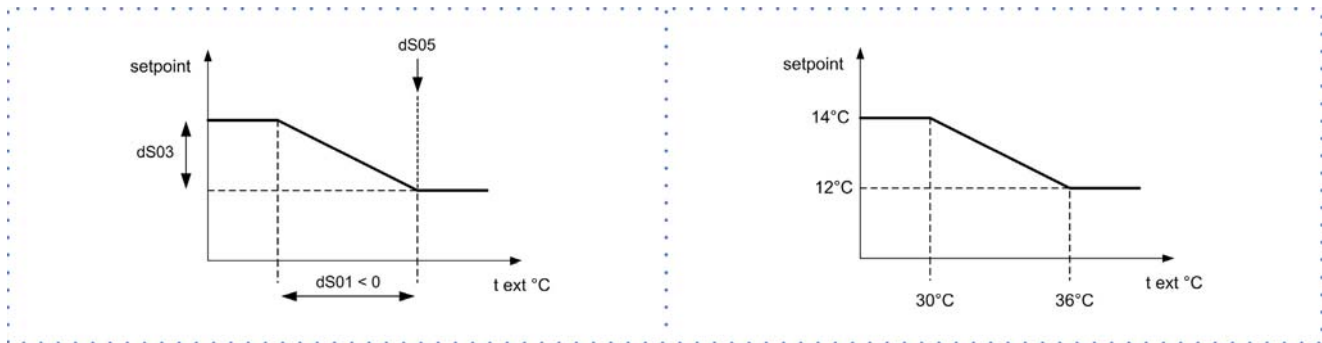

Example:

setpoint = 10°C

compensated setpoint = 14°C

Cool	Description	Example
dS01	Temperature controller dynamic differential proportional band in Cool	dS01 = - 6°C
dS03	Maximum temperature controller dynamic differential in Cool	dS03 = 4°C
dS05	Temperature controller dynamic differential setpoint in Cool	dS05 = 36°C

7.13 Minimum pump speed setting

Only for units fitted with an EC circulator.

The flow switch must not be tripped with the circulator at minimum speed and the system under the maximum pressure drop conditions.

Inspection and setting procedure:

Parameter modification	Keys	Esc	+	Set	▶	Menu	dS	▶	Menu	PI
------------------------	------	-----	---	-----	---	------	----	---	------	----

1. note down the PI31 value
2. set par. PI31=PI30
3. note down the PI41 value
4. set par. PI41=PI40
5. if the E020 alarm appears, proceed from section 8
6. if the E020 alarm does not appear, proceed from section 10
7. reset the alarm
8. increase PI30 and PI31 by the same value
9. repeat the step on PI40 and PI41 with the unit in heating mode
10. set PI31 back to the initial value
11. set PI41 back to the initial value

On systems with low pressure drops, the default settings of PI30 and PI40 can be decreased

PI30 Minimum water pump speed in Cool mode

PI31 Maximum water pump speed in Cool mode

7.14 Circulating pump: energy saving mode

Parameter modification	Keys	Esc	+	Set	▶	Menu	dS	▶	Menu	PI
------------------------	------	-----	---	-----	---	------	----	---	------	----

The function is enabled by default
 To deactivate the function: PI22 = 0

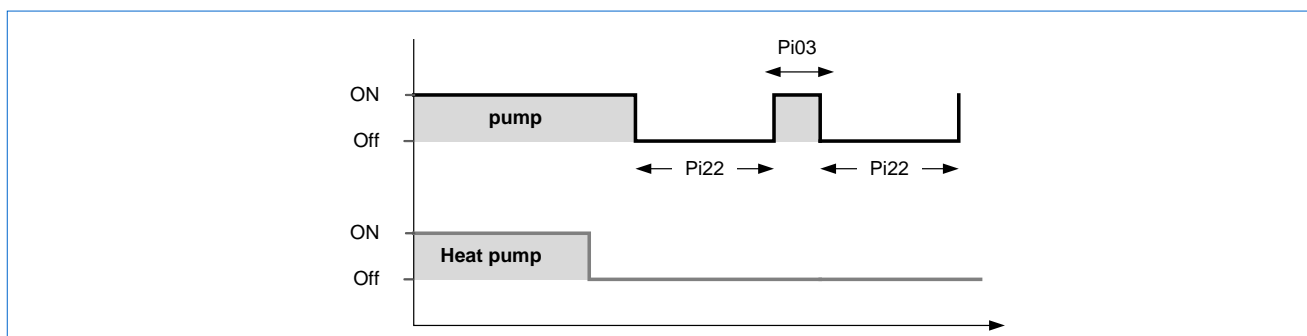

7.15 Circulating pump: anti-lock function

The function prevents mechanical locks of the circulation pump caused by prolonged inactivity.

Parameter modification	Keys	Esc	+	Set	▶	Menu	dS	▶	Menu	PI
------------------------	------	-----	---	-----	---	------	----	---	------	----

PI01 max. switch-off time of the circulating pump.
 PI03 switch-on time of the circulating pump

The function is enabled by default
 To deactivate the function: PI01 = 0

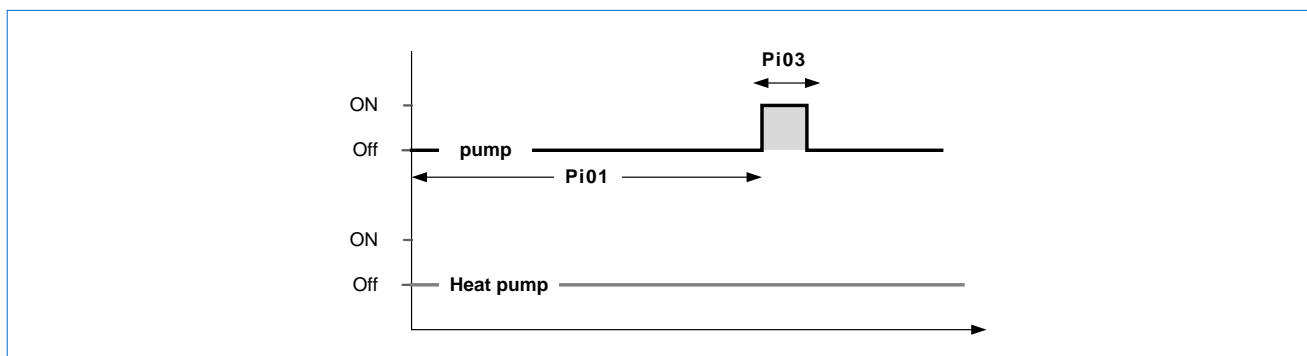

7.16 Antifreeze function with circulating pump

Parameter modification	Keys	Esc	+	Set	▶	Menu	dS	▶	Menu	PI
------------------------	------	-----	---	-----	---	------	----	---	------	----

PI51 switch-on setpoint of the circulating pump for antifreeze (5°C)

PI52 hysteresis (2°C)

The function is enabled by default

To deactivate the function: PI50 = 0.

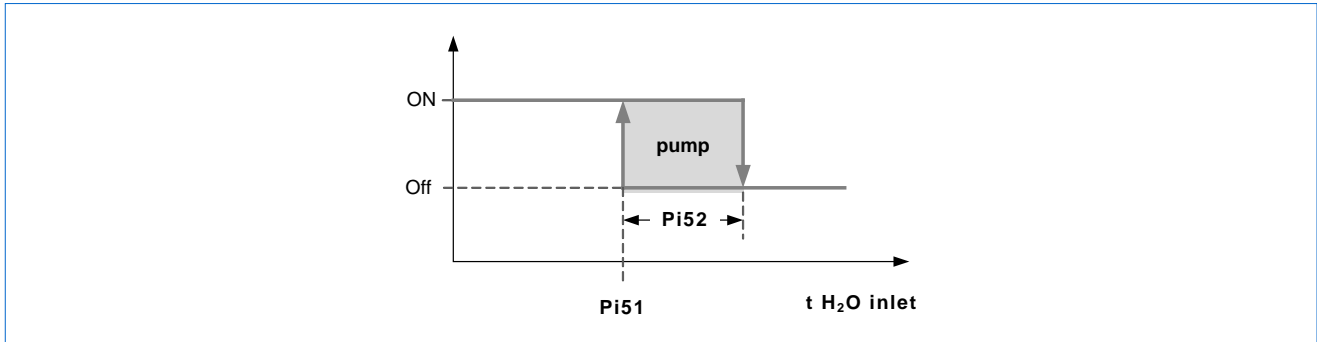

7.17 Start-up report

Identifying the operating objective conditions is useful to control the unit over time.

With unit at steady state, i.e. in stable and close-to-work conditions, identify the following data:

- total voltages and absorptions with unit at full load
- absorptions of the different electric loads (compressors, fans, pumps etc)
- temperatures and flows of the different fluids (water, air) both in input and in output from the unit
- temperature and pressures on the characteristic points of the refrigerating circuit (compressor discharge, liquid, intake)

The measurements must be kept and made available during maintenance interventions.

7.18 2014/68/UE PED directive

DIRECTIVE 2014/68/UE PED gives instructions for installers, users and maintenance technicians as well.

Refer to local regulations; briefly and as an example, see the following:

Compulsory verification of the first installation:

- only for units assembled on the installer's building site (for ex. Condensing circuit + direct expansion unit)

Certification of setting in service:

- for all the units

Periodical verifications:

- to be executed with the frequency indicated by the Manufacturer (see the "maintenance inspections" paragraph)

8 Control



8.1 Display

Icon	Fixed on	Flashing	Icon	
	Alarm on progress	Silenced alarm		Compressor
	Not used			Ventilation
	Cooling mode	Remote cooling mode	LAMP TEST	At the start-up is performed a board automatic test: all the led flash for some seconds
	Standby from keypad	Remote standby		Primary circuit water pump
	not used currently			Remote control Display shows Clock (not related to scheduling)
	Clock Active scheduling	Clock setting Scheduling		Water set point compensation active
	Not used			

8.2 Keys

Symbol	Name	Action	Function (3 sec.)	
	Up	Increases the value Next voice		Silenced alarm
	Down	Decreases the value Previous voice		On/Standby
	Esc	Esc WITHOUT SAVING MODIFICATIONS Previous level	mode	Cool / stbby
	Set	Confirm Esc WITH MODIFICATION SAVING Go to the next level STATA menu		Inputs / clock / stby / active alarms
		Activate / deactivate the time bands		
		Access to the SETTING menu		Parameters / function / password / alarms

* Unit in OFF the antifreeze function is not active.

8.3 Navigation

 Press 2 sec.	OPERATING MODE	Heat	Not used
		Cool	Cooling
		StdBY	On/Standby
		AS	not used currently

	STATA	Ai	Analogical inputs
		AO	Analogical outputs
		of	Digital inputs
		dO	Digital outputs
		CL	Clock
		AL	Active alarms
		HR	Compressor operating hours
		Sr	Setpoint

	SCHEDULING	PAR - parameters	Configuration
		Fnc - functions	dEF - not used tA - alarm reset St - on / off CC - copy card EUr - alarm log reset
		PASS - password	
		EU - alarms	Alarm log

8.4 Stand-by

Step	Display	Action	Keys	Menu/Variable	Notes
1	Main menu	Press 3 sec.		Stand-by	
2	Stand-by	Press 3 sec.		ON	

If CL43 = -1 key DOWN not enable

Active functions in standby:

7.16 Antifreeze function with circulating pump p. 28

7.15 Circulating pump: anti-lock function p. 27

8.5 ON/OFF

OFF: Emergency stop, the unit stops immediately without observing any timing.

Not active the antifreeze heaters etc.











Step	Display	Action	Keys	Menu/Variable	Notes
1	Main menu	Press		PAr	
2	PAr	Select		FnC	
3	FnC	Press		dEF	
4	dEF	Select		St	
5	St	Press			
6	ON/OFF	Press			
7		Press		Back to the previous menu	

8.6 Change the operating mode









Step	Display	Action	Keys		Menu/Variable	Notes
1	Main menu	Press 2 sec.			Cool	*
2	Cool	Select			Choose standby: STBY cool: COOL	
3	Cool	Confirm				

* Off the unit is immediately stopped without respecting any timing.
 Standby the antifreeze function is active (pump ON for water temperature < 4°C).
 The circulator anti-blocking function is active (pump ON at predefined intervals).

8.7 Water setpoint modification

Step	Display	Action	Keys		Menu/Variable	Notes
1	Main menu	Press			Ai	
2	Ai	Select			SP	
3	SP	Access			Cool	
4	Cool	Select			Choose Cool	
5	Cool	Confirm			50	
6	50	Press			Set the value 55	
7	55	Confirm			55	
8		Press			Back to the previous menu	

8.8 Display of inputs - outputs

Step	Display	Action	Keys		Menu/Variable	Notes
1	Main menu	Press			Ai	
2	Ai	Choose menu			Ai: analogical inputs di: digital inputs AO: analogical outputs dO: digital outputs	
3	of	Access			diL1	
4	diL1	Scroll the list			Choose diL4	
5	diL4	Press to see the value			For digital inputs: 0 = input not active - open 1 = input active - closed	
6		Press			Back to the previous menu	

For details see:
 10.4 Status p. 46

8.9 Silenced alarm

Before resetting an alarm identify and remove its cause.
Repeated resets can cause irreversible damage.

Step	Display	Action	Keys		Menu/Variable	Notes
1	Er01				The alarm code is flashing	
2	13.5°C				Alternated to temperature	
3					Fixed ALARM led	
4		Press any button				
5					ALARM led is flashing	

For details see:
10.1 Alarms p. 45

8.10 Alarms

Step	Display	Action	Keys		Menu/Variable	Notes
1	Main menu	Press			Ai	
2	Ai	Select			ALARM menu Ai	
3	Al	Press			Access 1° active alarm	
4	Er01	Scroll			Other active alarms	
5		Press			Back to the previous menu	

For details see:
10.1 Alarms p. 45

8.11 Alarm reset

















Before resetting an alarm identify and remove its cause.
Repeated resets can cause irreversible damage.

Step	Display	Action	Keys		Menu/Variable	Notes
1	Main menu	Press			PAr	
2	PAr	Select			FnC	
3	FnC	Press			dEF	
4	dEF	Select			tA	
5	tA	Press				
6		Press			Back to the previous menu	

For details see:
10.1 Alarms p. 45

8.12 Alarm log









 Before resetting an alarm identify and remove its cause.
Repeated resets can cause irreversible damage.

Step	Display	Action	Keys		Menu/Variable	Notes
1	Main menu	Press			PAr	
2	PAr	Select			EU	
3	EU	Press			Last registered alarm EU00	
4	EU00	Press			Access to alarm code info Er01	
5	Er01	Select			Hour of the alarm 20:01	
6	20:01	Select			Date of the alarm 27.10	
7	27.10	Select			Alarm output hour Example: alarm still active --:--	
8	--:--	Select			Alarm output date Example: alarm still active --:--	
9	--:--	Select			Type of alarm: AUto (automatic) MAnu (manual)	
10	AUto	Press				
11		Press			Back to the previous menu	

For details see:
10.1 Alarms p. 45











8.13 Alarms log reset

 Before resetting an alarm identify and remove its cause.
Repeated resets can cause irreversible damage.

Step	Display	Action	Keys		Menu/Variable	Notes
1	Main menu	Press			PAr	
2	PAr	Select			FnC	
3	FnC	Press			dEF	
4	dEF	Select			EUr	
5	EUr	Press 3 sec.			YES	
6		Press			Back to the previous menu	

For details see:
10.1 Alarms p. 45

8.14 Clock setting

Step	Display	Action	Keys		Menu/Variable	Notes
1	Main menu	Press			Ai	
2	Ai	Select			CLOCK menu	
3	CL	Access			Hour	
4	Hour	Select			Choose hour: HOUR date: DATE year: YEAR	
5	YEAR	Press 3 sec.			Confirm ! Value flashing !	
6	! 2012 !	Press			Set the value	
7	! 2013 !	Confirm			2013	
8		Press			Back to step 4	

8.15 Setting menu

access to the configuration parameters

Keys Esc + Set → Menu PAr

SETTING menu - PAR (configuration parameters)		
Label	Acronym meaning (label)	Parameters of:
CL	Configuration Local	Local I/O Configuration
CE	Configuration Expansion	Expansion I/O Configuration
Cr	Configuration Remote terminal	Remote terminal I/O Configuration
CF	ConFiguration	Configuration
Ui	User interface	User interface
tr	thermoregulation	Thermoregulation
St	Stati (Operating modes)	Operating stata
CP	ComPressori	Compressor
PI	Pump (Internal)	Primary circuit water pump
FI	Fan (Internal)	not used currently
FE	Fan (External)	Fans (external) of the disposable exchanger
PE	Pump (External)	Not used
Hi	Electric Heaters (Internal)	Electric heaters of the primary exchanger
HE	Electric Heaters (External)	not used currently
HA	Auxiliary Output	Not used
br	Boiler	not used currently
dF	Defrost	Defrosting
dS	dynamic Setpoint	Dynamic Setpoint
Ad	Adaptive	Adaptive (adaptive function)
AF	AntiFreeze	Anti-ice
AS	Domestic hot water, Anti-Legionella	Domestic hot water, Anti-Legionella
HP	Heat Pump	Not used
PL	Power Limitation	not used currently
tE	Time Events	Time bands
AL	ALarm	Alarms

8.16 Scheduling management

It is possible to set 3 different schedulings.

To each scheduling is possible to associate 4 events.

To each day of the week is possible to associate a scheduling.

In the example the schedulings have been assigned:

To enable the hour scheduling set the parameters tE00 and CL43:

Par tE00 hour scheduling

0 = disabled, 1 = enabled

Parameter modification

Keys Esc + Set → Menu PAR → Menu

Set the scheduling				
1	set the scheduling num.1	scheduling 1 parameters	scheduling 2 parameters	scheduling 3 parameters
1.1	set event 1	Event hour ☒ par. tE10 Event minutes ☒ par. tE11 Unit mode ☒ par. tE12 (0=On, 1=standby) Cooling temperature ☒ par. tE13 *	tE38 tE39 tE40 tE41	tE66 tE67 tE68 tE69
1.2	set event 2	Event hour ☒ par. tE17 Event minutes ☒ par. tE18 Unit mode ☒ par. tE19 (0=On, 1=standby) Cooling temperature ☒ par. tE20 *	tE45 tE46 tE47 tE48	tE73 tE74 tE75 tE76
1.3	set event 3	Event hour ☒ par. tE24 Event minutes ☒ par. tE25 Unit mode ☒ par. tE26 (0=On, 1=standby) Cooling temperature ☒ par. tE27 *	tE52 tE53 tE54 tE55	tE80 tE81 tE82 tE83
1.4	set event 4	Event hour ☒ par. tE31 Event minutes ☒ par. tE32 Unit mode ☒ par. tE33 (0=On, 1=standby) Cooling temperature ☒ par. tE34 *	tE59 tE60 tE61 tE62	tE87 tE88 tE89 tE90
2	set the scheduling num.2	column ☒ scheduling 2 parameters		
3	set the scheduling num.3	column ☒ scheduling 3 parameters		
4	assign the scheduling to monday	tE01 = 1 scheduling 1	= 2 scheduling 2	= 3 scheduling 3
5	assign the scheduling to tuesday	tE02 = 1 scheduling 1	= 2 scheduling 2	= 3 scheduling 3
6	assign the scheduling to wednesday	tE03 = 1 scheduling 1	= 2 scheduling 2	= 3 scheduling 3
7	assign the scheduling to thursday	tE04 = 1 scheduling 1	= 2 scheduling 2	= 3 scheduling 3
8	assign the scheduling to friday	tE05 = 1 scheduling 1	= 2 scheduling 2	= 3 scheduling 3
9	assign the scheduling to saturday	tE06 = 1 scheduling 1	= 2 scheduling 2	= 3 scheduling 3
10	assign the scheduling to sunday	tE07 = 1 scheduling 1	= 2 scheduling 2	= 3 scheduling 3

Example: scheduling 1

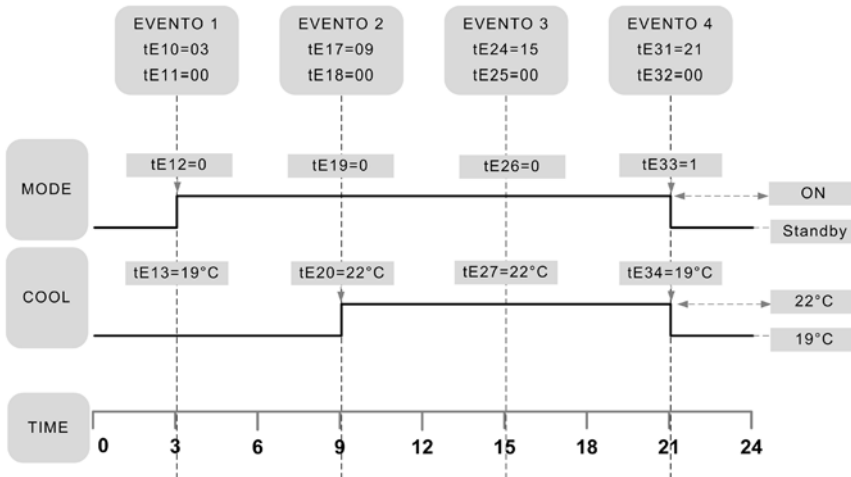

Example with active scheduling

- A manual modification of the cool setpoint: key Set → SP menu → Cool
- B manual modification of the cool setpoint: key Set → SP menu → Cool

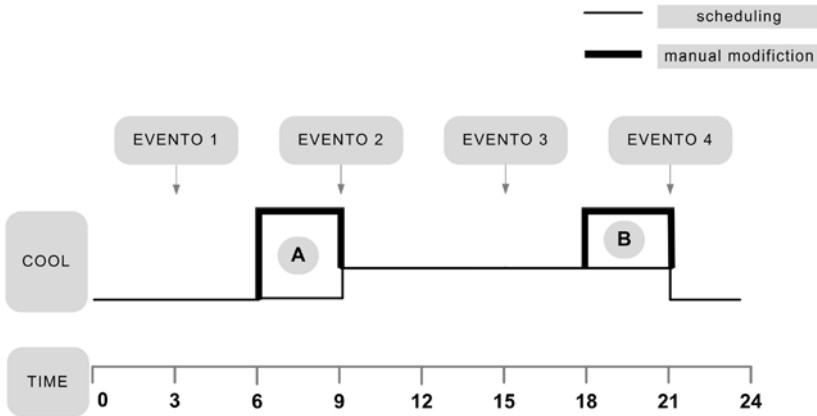

Activation scheduling example

- C activation scheduling: Keys ▲ ▼

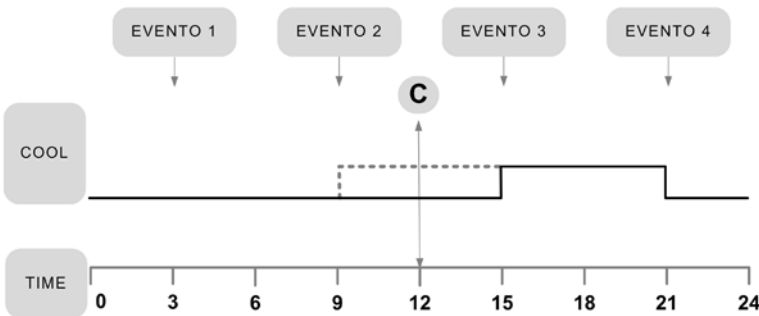

Events parameters

Event 1		Sched. 1 (par.)	Sched. 2 (par.)	Sched. 3 (par.)
	Time	tE10	tE38	tE66
	Minutes	tE11	tE39	tE67
	Mode 0= on 1= standby	tE12	tE40	tE68
Cooling temperature	tE13	tE41	tE69	

Event 2	Time	tE17	tE45	tE73
	Minutes	tE18	tE50	tE74
	Mode 0= on 1= standby	tE19	tE47	tE75
	Cooling temperature	tE20	tE48	tE76

Event 3	Time	tE24	tE52	tE80
	Minutes	tE25	tE53	tE81
	Mode 0= on 1= standby	tE26	tE54	tE82
	Cooling temperature	tE27	tE55	tE83

Event 4	Time	tE31	tE59	tE87
	Minutes	tE32	tE60	tE88
	Mode 0= on 1= standby	tE33	tE61	tE89
	Cooling temperature	tE34	tE62	tE90

8.17 Remote control - option

The keyboard repeats all the built-in control functions.

For details see:

8 Control p. 29













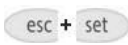

8.18 Ambient temperature display





It is possible to set the keypad to display the ambient temperature.

The probe is not used to perform the ambient thermoregulation.

Follow these steps:

Step	Display	Action	Keys		Menu/Variable	Notes
1	Main menu	Press			PAr	
2	PAr	Press			PAr	
3	PAr	Select			Cr	
4	Cr	Press			Cr..	
5	Cr..	Select			Cr00 Anable ambient probe	
6	Cr00	Confirm			0	
7	0	Select			2	
8	2	Confirm			2	
9		Press			Back to the previous menu	
10		Select			Cr30 Temperature display	
11	Cr30	Confirm			0	
12	0	Select			16	
13	16	Confirm				
14		Press			Back to the previous menu	

Step	Display	Action	Keys		Menu/Variable	Notes
1	Main menu	Press			PAr	
2	PAr	Press			PAr	
3	PAr	Select			Ui	
4	Ui	Press			Ui..	
5	Ui..	Select			Ui22	
6	Ui22	Confirm			0	
7	0	Select			1	
8	1	Confirm			1	
9		Press			Back to the previous menu	

Step	Display	Action	Keys		Menu/Variable	Notes
1	Main menu	Press 3 sec.				
2		Select			Air1	
3	Air1	Press				

Is it possible to disable the ambient keyboard:

Cr00 = 0

Cr30 = 0

To enable water setpoint compensation with ambient temperature set:

Cr 30 = 10

9 Maintenance

9.1 General description

Maintenance must be done by authorized centres or by qualified personnel.

The maintenance allows to:

- maintain the unit efficiency
- increase the life span of the equipment
- assemble information and data to understand the state of the unit efficiency and avoid possible damages

Before checking, please verify the following:

- the electrical power supply line should be isolated at the beginning
- the unit isolator is open, locked and equipped with the suitable warning
- make sure no tension is present



After turning off the power, wait at least 5 minutes before accessing to the electrical panel or any other electrical component.



Before accessing check with a multimeter that there are no residual stresses.

9.2 Inspections frequency

Perform an inspection every 6 months minimum.

The frequency, however, depends on the use.



In the event of frequent use it is recommended to plan inspections at shorter intervals:

- frequent use (continuous or very intermittent use, near the operating limits, etc)
- critical use (service necessary)

9.3 Unit booklet

It's advisable to create a unit booklet to take notes of the unit interventions.

In this way it will be easier to adequately note the various interventions and aid any troubleshooting.

Report on the booklet:

- date
- type of intervention effected
- intervention description
- carried out measures etc.

9.4 Standby mode

If a long period of inactivity is foreseen:

- turn off the power
- avoid the risk of frost (empty the system or add glycol)

Turn off the power to avoid electrical risks or damages by lightning strikes.



With lower temperatures keep heaters turned on in of the electrical panel (option).

It's recommended that the re-start after the stopping period is performed by a qualified technician, especially after seasonal stops or seasonal switching.

When restarting, refer to what is indicated in the "start-up" section.

Schedule technical assistance in advance to avoid hitches and to guarantee that the system can be used when required.

9.5 Main components

(sizes 21÷71)

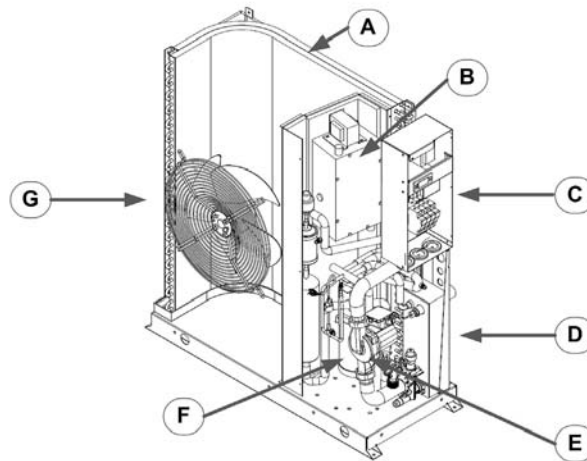

- A. Coil
- B. Inverter
- C. Electrical panel
- D. Exchanger

- E. pump
- F. Compressor
- G. Fan

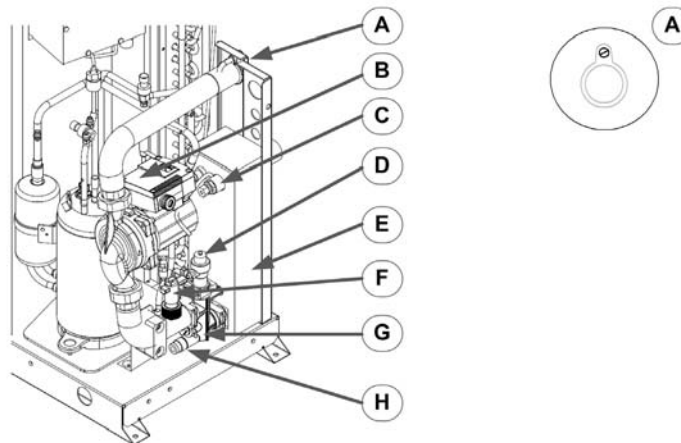

- A. vent
- B. pump
- C. input probe
- D. Safety valve (6 Bar)

- E. plate exchanger
- F. Flow Switch
- G. input probe
- H. water outlet

(size 81÷141)

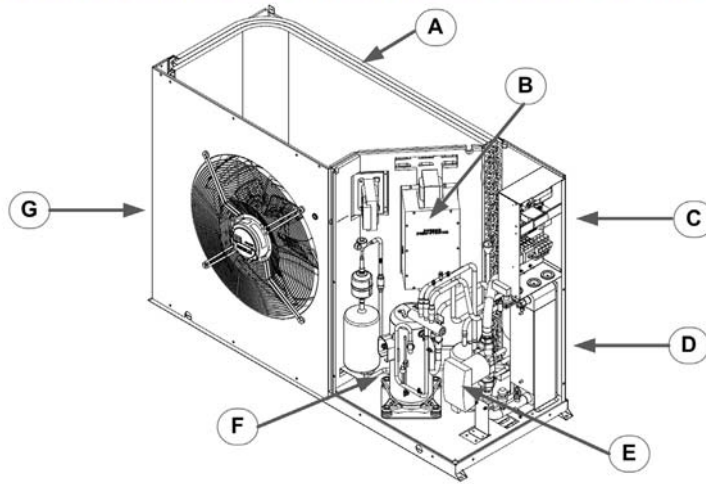

- A. Coil
- B. Inverter
- C. Electrical panel
- D. Exchanger

- E. pump
- F. Compressor
- G. Fan

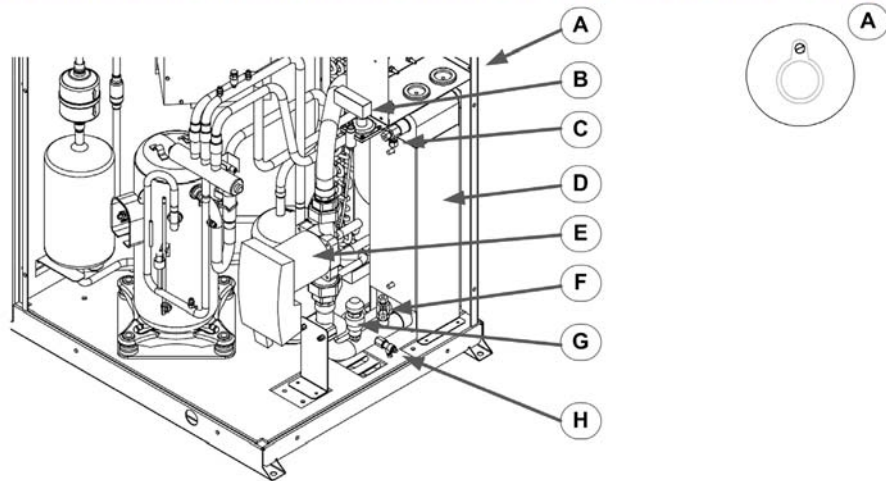

- A. vent
- B. Differential pressure switch
- C. input probe
- D. plate exchanger

- E. pump
- F. input probe
- G. Safety valve (6 Bar)
- H. water outlet

9.6 Control check list

√		intervention frequency (months)	1	6	12
1	presence corrosion				X
2	panel fixing				X
3	fan fixing			X	
4	coil cleaning			X	
5	water filter cleaning			X	
6	check the exchanger efficiency				X
7	circulating pumps			X	
8	check of the fixing and the insulation of the power lead				X
9	check of the earthing cable				X
10	electric panel cleaning				X
11	capacity contactor status				X
12	terminal closing, cable insulation integrity				X
13	voltage and phase unbalancing (no load and on-load)			X	
14	absorptions of the single electrical loads			X	
15	test of the compressor crankcase heaters			X	
16	leak control*				X
17	survey of the refrigerant circuit operating parameters			X	
18	protective device test: pressure switches, thermostats, flow switches etc..			X	
19	control system test: setpoint, climatic compensations, capacity stepping, water / air flow-rate variations			X	
20	control device test: alarm signalling, thermometers, probes, pressure gauges etc..			X	

* European regulation 303/2008

Refer to the local regulations; and ensure correct adherence. Companies and technicians that effect interventions of installation, maintenance/repairs, leak control and recovery must be CERTIFIED as expected by the local regulations. The leak control must be effected with annual renewal.

9.7 Air coil

Contact with the exchanger fins can cause cuts: wear protective gloves to perform the above described operations.

It is extremely important that the battery gives the maximum thermal exchange; therefore, its surface must be cleaned from dust and deposits. Remove all impurities from the surface.

Using an air pressure gun, clean the aluminum surface of the battery; be careful to direct the air in the opposite direction of the fan air movement.

Hold the gun parallel to the fins to avoid damages.

As an alternative, vacuum cleaner can be used to suck impurities from the air input side.



Verify that the aluminum fins are not bent or damaged, in the event of damages contact the authorized assistance center and get the fins straightened in order to restore the initial condition for an optimal air flow.

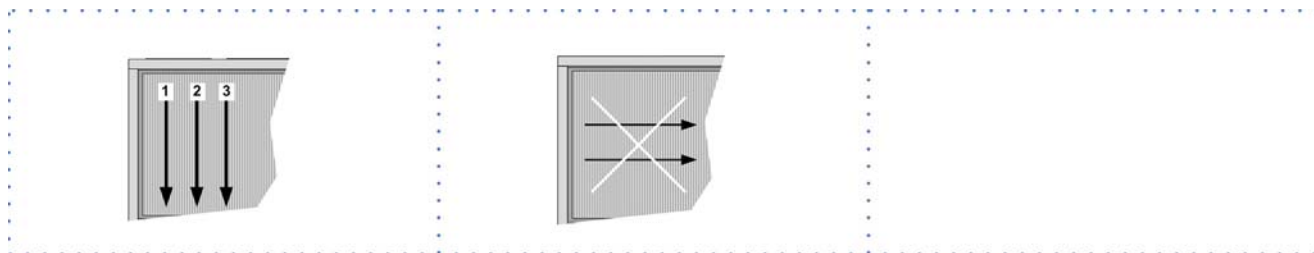

9.8 Water side exchanger

It is very important for the exchanger to be able to provide the maximum thermal exchange, therefore it is essential for the inner surfaces to be clean of dirt and incrustations.

Periodically check the difference between the temperature of the supply water and the condensation temperature: if the difference is greater than 8°C–10°C it is advisable to clean the exchanger.

The clearing must be effected:

- with circulation opposite to the usual one
- with a speed at least 1,5 times higher than the nominal one
- with an appropriate product moderately acid (95% water + 5% phosphoric acid)
- after the cleaning rinse with water to inhibit the action of any residual product

9.9 Water filter

Check that no impurities prevent the correct passage of water.

9.10 Flow Switch

- controls the operations
- remove incrustations from the palette

9.11 Electric fans

Check:

- the fans and the relative protection grids are well fixed
- the fan bearings (evident by noise and anomalous vibrations)
- the terminal protection covers are closed and the cable holders are properly positioned

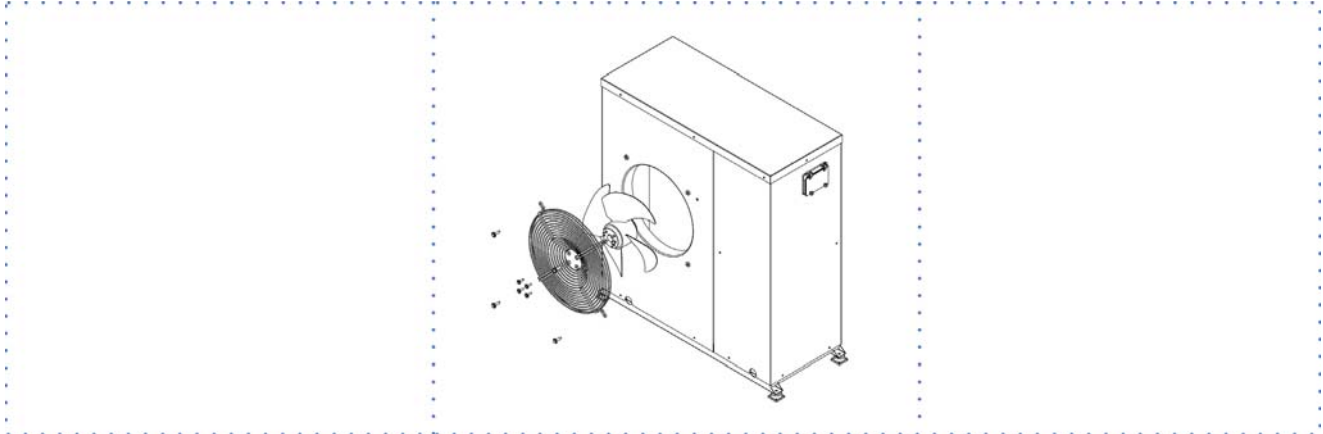

9.12 Circulating pumps

Check:

- no leaks
- bearing status (anomalies are highlighted by abnormal noise and vibration)
- the terminal protection covers are closed and the cable holders are properly positioned

9.13 Probe position

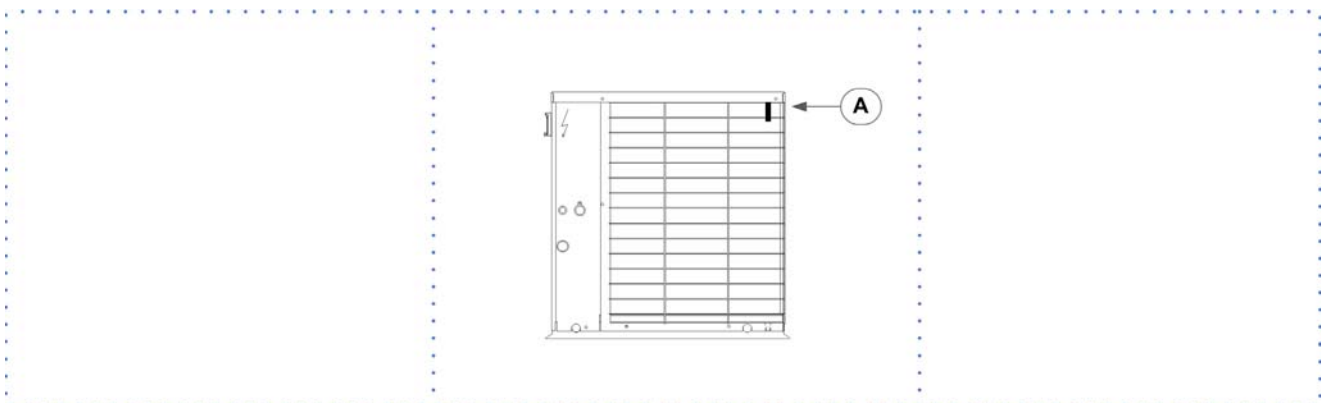

A. Fresh air probe

10 Alarms - Status

10.1 Alarms

-  Before resetting an alarm identify and remove its cause.
Repeated resets can cause irreversible damage.

Code	Description	Type
E000	General alarm	AUTO
E001	High pressure (digital) circuit	*
E003	High pressure (analogical) circuit	*
E007	Low pressure (analogical) circuit	*
E010	Inverter alarm	*
E020	Primary circuit flow switch	Time
E030	Primary circuit antifreeze	AUTO
E035	Primary circuit output high temperature	AUTO
E045	Faulty clock error	AUTO
E046	Error: Clock to set	AUTO
E047	Error of LAN communication between main module and electronic thermostatic module or ambient keyboard (if present) or DHW module (if present)	AUTO
E048	Anti-legionella	AUTO
E060	Faulty water temperature probe or primary exchanger input	AUTO
E061	Faulty water temperature probe or primary exchanger output	AUTO
E062	Faulty exchanger temperature probe	AUTO
E065	Faulty ambient keyboard temperature probe	AUTO
E066	Faulty DHW temperature probe	AUTO
E068	Faulty external temperature probe	AUTO
E069	Faulty high pressure input circuit	AUTO
E071	Faulty compressor discharge temperature probe	AUTO
E080	Configuration error	AUTO
E081	Signalling of compressor operating hour exceeding	Manual
E085	Signalling of primary circuit pump operating hour exceeding	Manual
E090	Signalling of alarm log record exceeding	Manual

A = AUTOMATIC reset

M = MANUAL reset

* after some interventions is necessary the manual reset

10.2 Electronic thermostatic driver alarm

Code	Description	Type
E101	Faulty low pressure trasducer - 1Ai1	AUTO
E102	Faulty low pressure temperature probe - 1Ai2	AUTO
E103	Faulty discharge temperature probe - 1Ai3	AUTO
E106	Saturation output error	AUTO
E107	MOP alarm	AUTO
E108	Signalling of valve max opening	AUTO
E110	NO link alarm	AUTO
E111	Excessive current draw	* Manual
E112	Winding 1 disconnection	* Manual
E113	Winding 1 short circuit	* Manual
E114	Winding 2 disconnection	* Manual
E115	Winding 2 short circuit	* Manual

A = AUTOMATIC reset

* Switch on and off the electronic thermostatic driver

10.3 Led inverter

The access is reserved to the service centres.



Danger of electrocution.

Led:

ON: normal operating

Slow flashing (ON 1sec.,OFF 0.5 sec.): standby compressor stopped

Fast flashing (ON 0.2 sec.,OFF 0.2 sec.): in alarm.

10.4 Status

Main menu SET Ai, di, AO, dO Ai L1

Menu	Code	Description
Ai	AiE1	DHW temperature Not used
	Ai L1	Primary outlet temperature
	Ai L2	Primary inlet temperature
	Ai L3	Coil temperature
	Ai L4	High pressure transducer
	Ai L5	Outside temperature
	1Ai 1	Low pressure transducer (thermostatic sensor on the driver)
	1Ai 2	Return temperature (thermostatic sensor on the driver)
of	1Ai 3	Discharge temperature (thermostatic sensor on the driver)
	di L1	High pressure
	di L2	Compressor Alarm
	di L3	Flow user side
	di L4	On / Standby remote
AO	di L5	Remote Heat/Cool not used currently
	A0 L1	Primary pump (it is a digital 0/1)
	A0 L2	Fan signal (standard version)
	A0 L3	Compressor signal
	A0 L4	Primary pump signal (if in variable flow)
dO	A0 L5	Fan signal (High-efficiency version)
	d0E1	DHW heater (if present) Not used
	d0 L1	DHW valve not used currently
	d0 L2	Reversing valve refrigerant circuit Not used
	d0 L3	Frost Heater
	d0 L4	Auxiliary heater not used currently
	d0 L5	Compressor start
E1	d0 L6	Cumulative alarm
	1rE1	Superheating temperature
	1rE2	Condensing saturate temperature
	1rE5	Superheating
	1rE6	Gas pressure (=1Ai1)
	1rE7	Opening percentage electronic thermostatic valve
Sr	1SP4	Superheating Setpoint
		Actual Setpoint: setpoint with compensation / operating limit
Hr	CP01	Compressor 1 operating hours: x 10
	PU01	Hours utility pump: x 10

11 Accessories

11.1 RCTX - Remote control

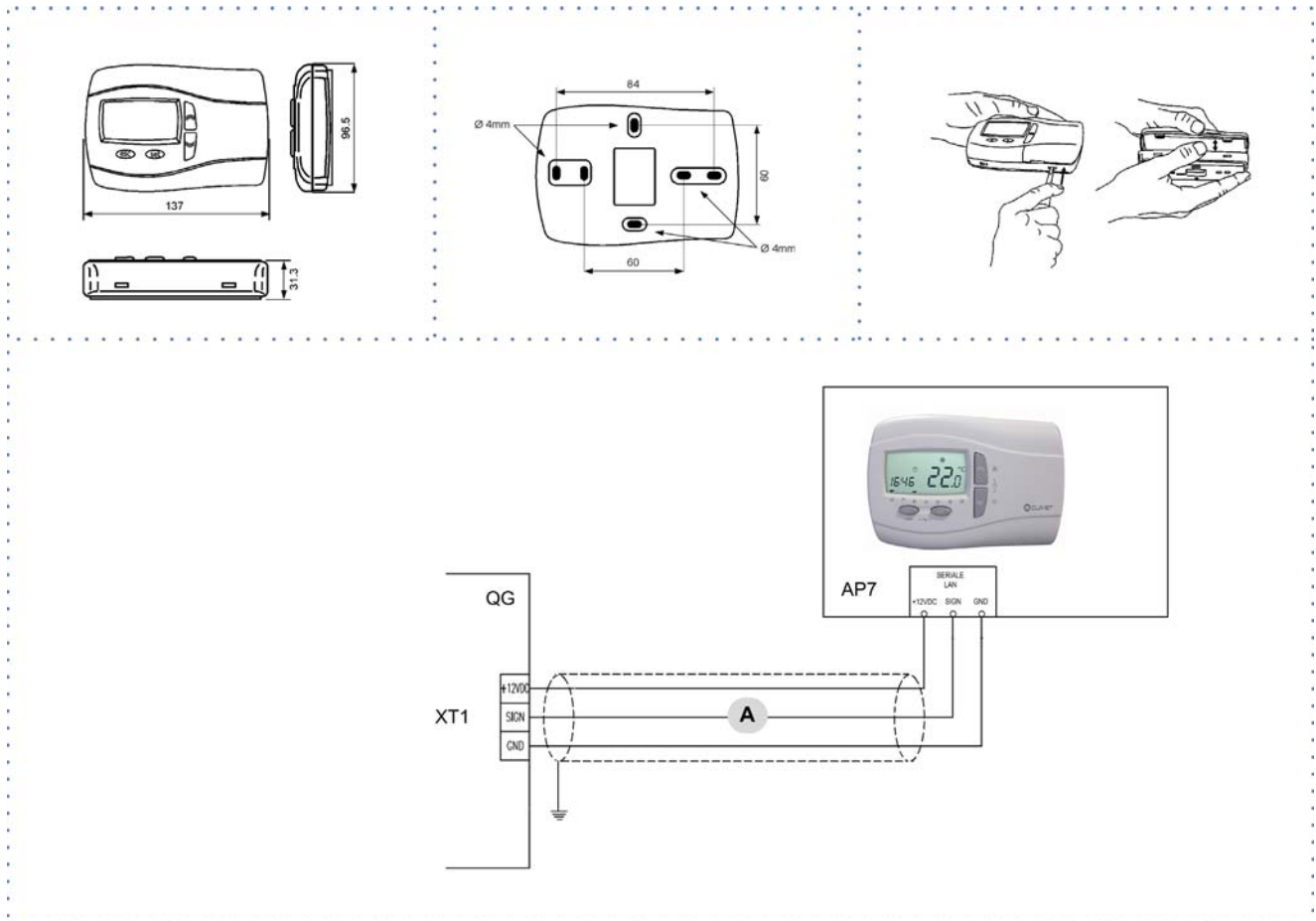

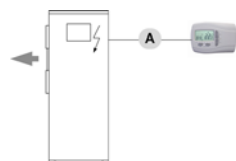

- QG** Electrical panel
- XT1** Terminal block of the customer connections
- AP7** Room keypad
- A** Max. = 100 mt.
Cable section:
Min. 0,35 Max.1 mm²

LAN net: A = 100 mt. Max

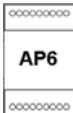

11.2 CMSC2X - Serial communication module with RS485 serial converter kit

1	Install the AP6 converter	
2	Connect TTL serial	
3	Wire as indicated in the wiring diagram.	

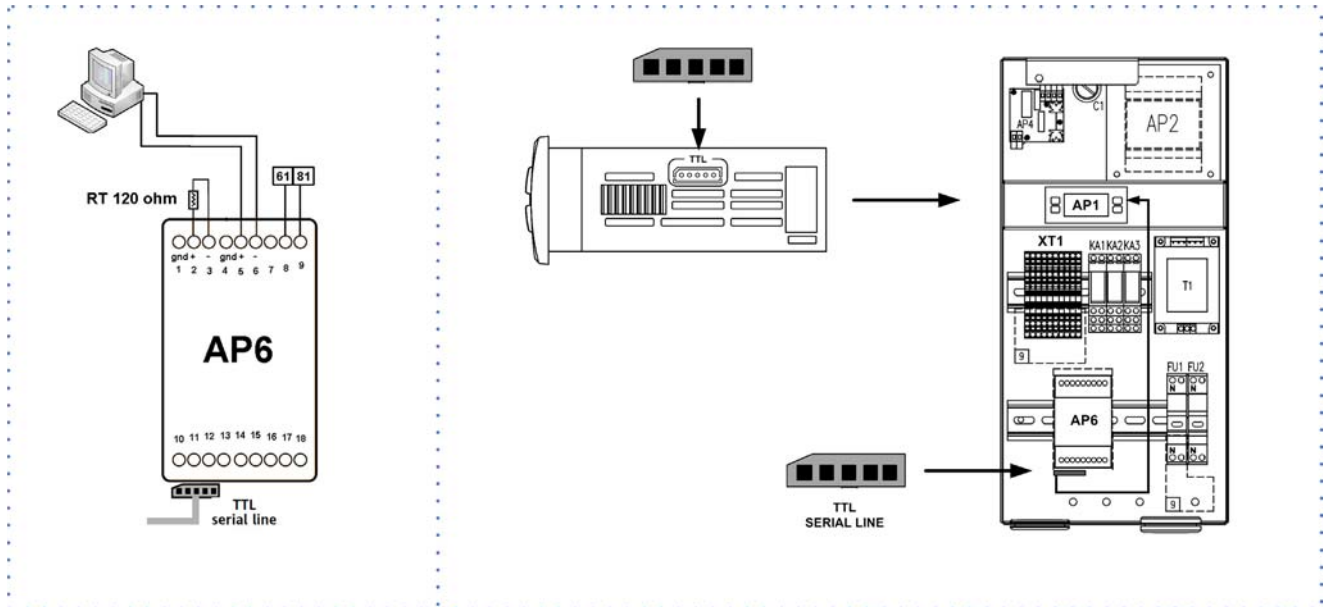

Supervisory

The unit can be connected to an external supervisory system.

Enable the function:

Par: CF01 protocol selection

0 = Disabled

1 = Modbus

Parameter modification

Main menu → Parameters → CF → CF01

Parameter	Description	Range
CF30	address Modbus	1....255
CF31	BaudRate	Baud Rate (0=1200 / 1=2400 / 2=4800 / 3=9600 / 4=19200) supervision serial

Cable characteristics

Couple of conductors twisted and shielded

Section of conductor 0,22mm²...0,35mm²

Rated power between conductors $\leq 50 \text{ pF/m}$

Nominal impedance 120 Ω

Recommended cable Belden 3105A or others with equal properties

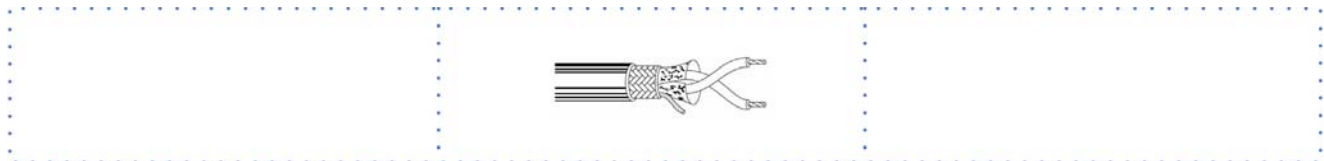

11.3 KG4UP - Management kit up to 4 units in parallel by the two set point available for each unit

Max 4 units
Automatic unit rotation

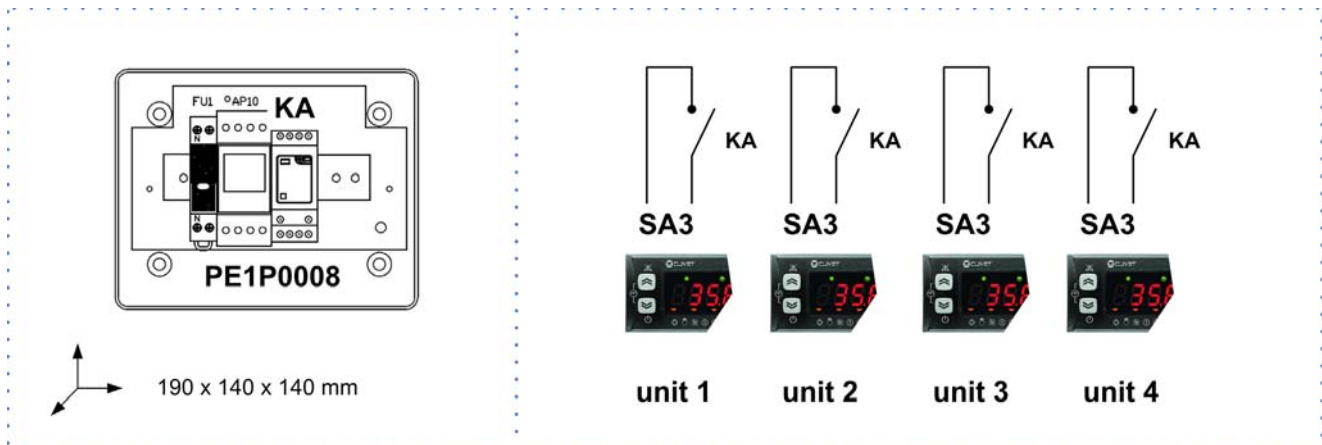

Connect PE1P0008 with SA3 unit 1, SA3 units 2, etc..
enable SA3 on unit 1, unit 2, etc.. (main menu \boxtimes Par \boxtimes CL \boxtimes CL45 = 22)
Set Tr15 on unit 1, unit 2, etc.. (main menu \boxtimes Par \boxtimes Tr \boxtimes Tr15)

example of Summer set point									
	2 units		3 units			4 units			
	unit 1	unit 2	unit 1	unit 2	unit 3	unit 1	unit 2	unit 3	unit 4
Summer set point (SPCool)	7	7,5	7	7,5	8	7	7,5	8	8,5
Tr15	0,5	-0,5	1	-0,5	-0,5	1,5	0,5	-0,5	-1,5
2° Summer set point (2°SPCool)	7,5	7	8	7	7,5	8,5	8	7,5	7

SCHEDULING EXAMPLE

monday: KA = OFF \boxtimes Enabled set summer, tuesday KA = ON \boxtimes 2° Enabled set summer, wednesday KA = OFF \boxtimes Enabled set summer



example summer scheduling			
	Monday	Tuesday	Wednesday
unit 1	7 (SPCool)	8,5 (2°SPCool)	7 (SPCool)
unit 2	7,5 (SPCool)	8 (2°SPCool)	7,5 (SPCool)
unit 3	8 (SPCool)	7,5 (2°SPCool)	8 (SPCool)
unit 4	8,5 (SPCool)	7 (2°SPCool)	8,5 (SPCool)

11.4 KSAX - 100-litre water circuit breaker

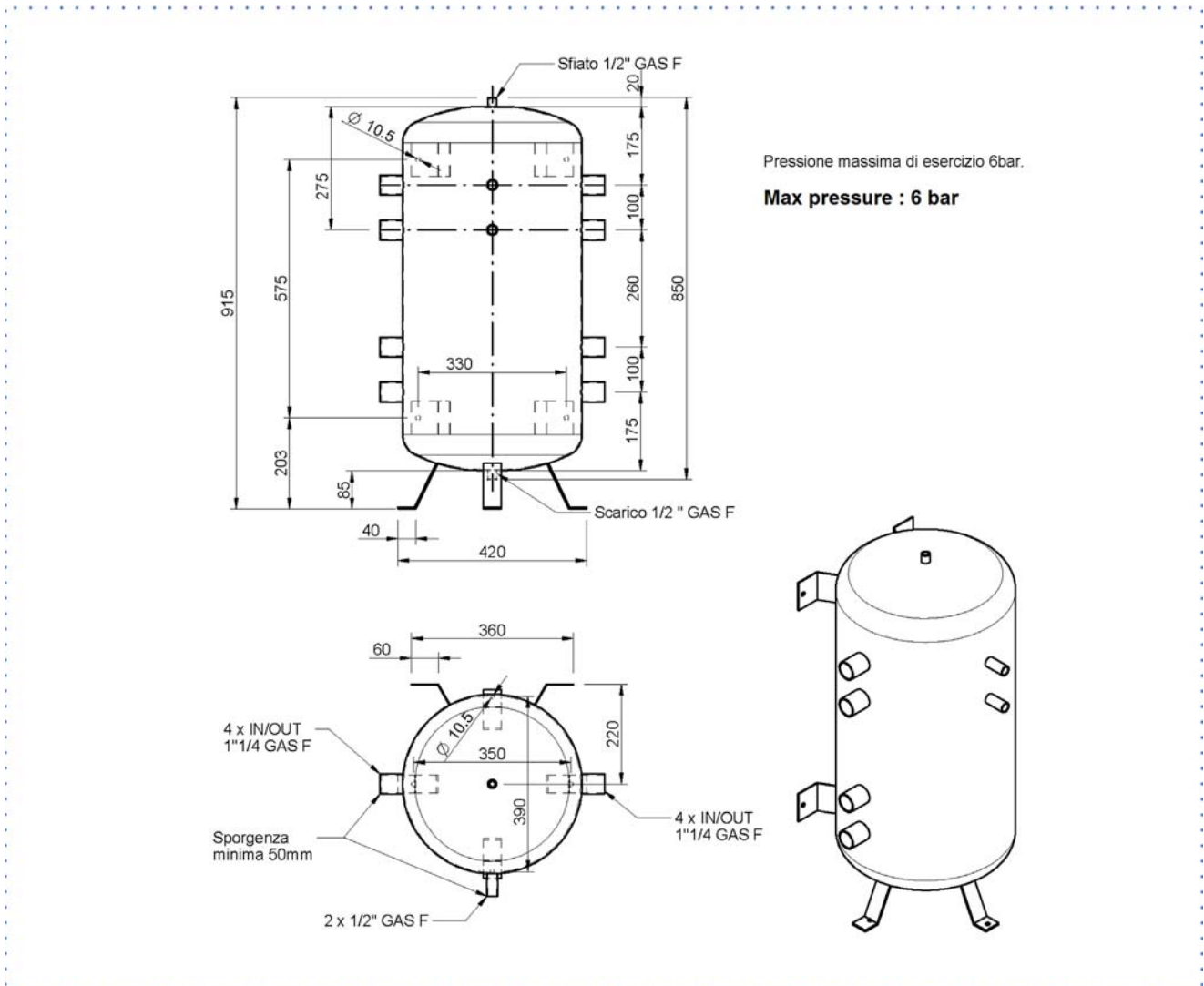
Storage in Fe360b and anti-corrosion treatment with organic enamel, 50 mm-thick polyethylene and polyurethane external insulation and a maximum operating pressure of 6 bar.



11.5 KTFLEX - Hose kit for connection to the chiller/heat pump

Size	No	
21-71	2x	 Connection of 1" between the unit and the system. Lenght 300 mm.
81-151	2x	 Connection of 1 1/4" between the unit and the system. Lenght 300 mm.
161-171	2x	 Connection of 1 1/2" between the unit and the system. Lenght 300 mm.

11.6 AMRX - Rubber antivibration mounts

Code	Size	W1	W2	W3	W4
PE181101	21-41	BB30 - 60 Sh	BB30 - 45 Sh	BB30 - 60 Sh	BB30 - 45 Sh
		RED	BEIGE	RED	BEIGE
PE181910	51-141	BB100 - 60 Sh	BB100 - 45 Sh	BB100 - 60 Sh	BB100 - 45 Sh
		RED	BEIGE	RED	BEIGE
PE182701	151-171	BB200 - 60 Sh	BB200 - 45 Sh	BB200 - 60 Sh	BB200 - 45 Sh
		RED	BEIGE	RED	BEIGE

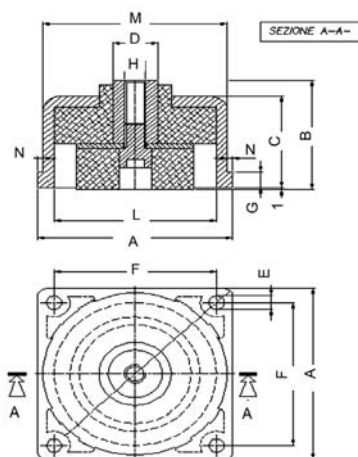
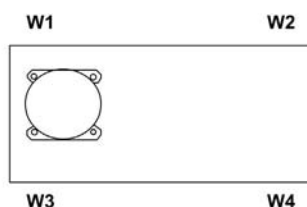

Dimensions

PE181101

A	B	C	D	E	F	G	H	L	M	N
59 mm	36 mm	27,5 mm	20 mm	6,5 mm	42 mm	8 mm	M8	42 mm	49 mm	5 mm

PE181910

A	B	C	D	E	F	G	H	L	M	N
88 mm	52 mm	41 mm	25 mm	11 mm	67 mm	10 mm	M12	65 mm	74,5 mm	5,5 mm

12 Decommissioning

12.1 Disconnecting

Only authorised personnel must disconnect the unit.

Avoid leak or spills into the environment.

Before disconnecting the unit, the following must be recovered, if present:

- refrigerant gas
- anti-freeze solutions in the water circuit

Awaiting dismantling and disposal, the unit can also be stored outdoors, if the electrical, cooling and water circuits of the unit have 100% integrity and are isolated, bad weather and rapid change in temperature will not result in any environmental impact.

12.2 Dismantling and disposal

The unit must always be sent to authorised centres for dismantling and disposal.

When dismantling the unit, the fan, the motor and the coil, if operating, may be recovered by the specialist centres for reuse.

All the materials must be recovered or disposed of in compliance with the corresponding national standards in force.

For further information on the decommissioning of the unit, contact the manufacturer.

12.3 Directive EC RAEE

The units covered by the legislation in question are marked with the symbol on the side.

With the aim of protecting the environment, all of our units are produced in compliance with Directive EC on waste electrical and electronic equipment (RAEE).

The potential effects on the environment and on human health due to the presence of hazardous substances are shown in the use and maintenance manual in the section on residual risks.

Information in addition to that indicated below, if required, can be obtained from the manufacturer/distributor/importer, who are responsible for the collection/handling of waste originating from equipment covered by EC-RAEE. This information is also available from the retailer who sold this appliance or from the local authorities who handle waste.

Directive EC-RAEE requires disposal and recycling of electrical and electronic equipment as described therein to be handled through appropriate collection, in suitable centres, separate from collection for the disposal of mixed urban waste.

The user must not dispose of the unit at the end of its life cycle as urban waste, it must instead be handed over to appropriate collection centres as set forth by current standards or as instructed by the distributor.



13 Residual risks

General description

In this section the most common situations are indicated, as these cannot be controlled by the manufacturer and could be a source of risk situations for people or things.

Danger zone

This is an area in which only an authorised operator may work.

The danger zone is the area inside the unit which is accessible only with the deliberate removal of protections or parts thereof.

Handling

The handling operations, if implemented without all of the protection necessary and without due caution, may cause the drop or the tipping of the unit with the consequent damage, even serious, to persons, things or the unit itself.

Handle the unit following the instructions provided in the present manual regarding the packaging and in compliance with the local regulations in force. Should the refrigerant leak please refer to the refrigerant "Safety sheet".

Installation

The incorrect installation of the unit could cause water leaks, condensate accumulation, leaking of the refrigerant, electric shock, poor operation or damage to the unit itself.

Check that the installation has been implemented by qualified technical personnel only and that the instructions contained in the present manual and the local regulations in force have been adhered to.

The installation of the unit in a place where even infrequent leaks of inflammable gas and the accumulation of this gas in the area surrounding the area occur could cause explosions or fires.

Carefully check the positioning of the unit.

The installation of the unit in a place unsuited to support its weight and/or guarantee adequate anchorage may result in consequent damage to things, people or the unit itself.

Carefully check the positioning and the anchoring of the unit.

Easy access to the unit by children, unauthorised persons or animals may be the source of accidents, some serious.

Install the unit in areas which are only accessible to authorised person and/or provide protection against intrusion into the danger zone.

General risks

Smell of burning, smoke or other signals of serious anomalies may indicate a situation which could cause damage to people, things or the unit itself.

Electrically isolate the unit (yellow-red isolator).

Contact the authorised service centre to identify and resolve the problem at the source of the anomaly.

Accidental contact with exchange batteries, compressors, air delivery tubes or other components may cause injuries and/or burns.

Always wear suitable clothing including protective gloves to work inside the danger zone.

Maintenance and repair operations carried out by non-qualified personnel may cause damage to persons, things or the unit itself.

Always contact the qualified assistance centre.

Failing to close the unit panels or failure to check the correct tightening of all of the panelling fixing screws may cause damage to persons, things or the unit itself.

Periodically check that all of the panels are correctly closed and fixed.

If there is a fire the temperature of the refrigerant could reach values that increase the pressure to beyond the safety valve with the consequent possible projection of the refrigerant itself or explosion of the circuit parts that remain isolated by the closure of the tap.

Do not remain in the vicinity of the safety valve and never leave the refrigeration system taps closed.

Electric parts

An incomplete attachment line to the electric network or with incorrectly sized cables and/or unsuitable protective devices can cause electric shocks, intoxication, damage to the unit or fires.

Carry out all of the work on the electric system referring to the electric layout and the present manual ensuring the use of a system thereto dedicated.

An incorrect fixing of the electric components cover may lead to the entry of dust, water etc inside and may consequently electric shocks, damage to the unit or fires.

Always fix the unit cover properly.

When the metallic mass of the unit is under voltage and is not correctly connected to the earthing system it may be as source of electric shock and electrocution.

Always pay particular attention to the implementation of the earthing system connections.

Contact with parts under voltage accessible inside the unit after the removal of the guards can cause electric shocks, burns and electrocution.

Open and padlock the general isolator prior to removing the guards and signal work in progress with the appropriate sign.

Contact with parts that could be under voltage due to the start up of the unit may cause electric shocks, burns and electrocution.

When voltage is necessary for the circuit open the isolator on the attachment line of the unit itself, padlock it and display the appropriate warning sign.

Moving parts

Contact with the transmissions or with the fan aspiration can cause injuries.

Prior to entering the inside of the unit open the isolator situated on the connection line of the unit itself, padlock and display the appropriate warning sign.

Contact with the fans can cause injury.

Prior to removing the protective grill or the fans, open the isolator on the attachment line of the unit itself, padlock it and display the appropriate warning sign.

Refrigerant

The intervention of the safety valve and the consequent expulsion of the gas refrigerant may cause injuries and intoxication.

Always wear suitable clothing including protective gloves and eyeglasses for operations inside the danger zone.

Should the refrigerant leak please refer to the refrigerant "Safety sheet".

Contact between open flames or heat sources with the refrigerant or the heating of the gas circuit under pressure (e.g. during welding operations) may cause explosions or fires.

Do not place any heat source inside the danger zone.

The maintenance or repair interventions which include welding must be carried out with the system off.

Hydraulic parts

Defects in tubing, the attachments or the removal parts may cause a leak or water projection with the consequent damages to people, things or shortcircuit the unit.

PREMIUM VERSION

General technical data

Size			21	31	41	51	71	81	91	101	121	131	141
Radiant panels													
Cooling													
Cooling capacity	1	kW	4,25	6,33	8,07	10,3	13,0	16,0	18,8	21,0	26,5	29,5	33,1
Total power input	2	kW	1,14	1,75	2,18	2,83	3,52	4,22	5,11	5,94	7,12	7,95	9,32
EER (EN 14511:2013)	3		3,71	3,62	3,71	3,65	3,70	3,78	3,67	3,53	3,72	3,71	3,55
ESEER	4		4,92	4,84	5,22	4,81	5,57	5,48	5,85	6,02	5,61	5,79	5,94
Water flow-rate	1	l/s	0,20	0,30	0,39	0,49	0,62	0,76	0,90	1,00	1,27	1,41	1,58
Useful pump discharge head	1	kPa	65	58	61	53	66	76	71	66	68	61	51
ELFORoom and ELFOspace terminal units													
Cooling													
Cooling capacity	5	kW	4,39	5,64	8,01	10,1	13,1	15,5	17,5	19,6	25,3	27,8	30,6
Total power input	2	kW	1,65	2,11	2,99	3,88	5,22	5,53	6,53	8,03	9,57	10,8	12,8
EER (EN 14511:2013)	3		2,66	2,68	2,68	2,61	2,50	2,81	2,68	2,44	2,64	2,58	2,38
ESEER	6		3,83	3,70	3,88	4,08	4,12	4,33	4,39	4,50	4,23	4,36	4,39
Water flow-rate	5	l/s	0,21	0,27	0,38	0,48	0,63	0,74	0,84	0,94	1,21	1,33	1,46
Useful pump discharge head	5	kPa	64	61	61	55	66	77	73	69	70	65	58
Compressor													
Type of compressors			Rotary inverter dc					Scroll inverter DC					
Refrigerant			R-410A	R-410A	R-410A	R-410A	R-410A	R-410A	R-410A	R-410A	R-410A	R-410A	R-410A
No. of compressors		No	1	1	1	1	1	1	1	1	1	1	1
Oil charge		l	0,35	0,35	0,87	1,70	1,70	1,90	1,90	1,90	1,90	1,90	1,90
Refrigeration circuits		No	1	1	1	1	1	1	1	1	1	1	1
Refrigerant Charge		Kg	2,1	1,9	2,1	3,3	4,4	4,7	4,7	4,7	6,8	6,8	6,8
User side exchanger													
Type of internal exchanger	7		PHE	PHE	PHE	PHE	PHE	PHE	PHE	PHE	PHE	PHE	PHE
No. of exchangers		No	1	1	1	1	1	1	1	1	1	1	1
Water content		l	0,56	0,64	0,64	1,14	1,80	2,37	2,37	2,37	3,13	3,13	3,13
External Section Fans													
Type of fans	8		AX	AX	AX	AX	AX	AX	AX	AX	AX	AX	AX
No. of fans		No	1	1	1	2	2	1	1	1	2	2	2
Standard airflow		l/s	653	1028	1028	2081	1996	2167	2389	2444	3333	3889	4167
Installed unit power		kW	0,12	0,15	0,15	0,15	0,15	0,45	0,41	0,39	0,50	0,47	0,44
Water circuit													
Maximum water side pressure		kPa	550	550	550	550	550	550	550	550	550	550	550
Safety valve calibration		kPa	600	600	600	600	600	600	600	600	600	600	600
Min. installation water contents		l	17	20	25	33	40	50	53	57	63	68	74
Power supply													
Standard power supply			230/1/50	230/1/50	230/1/50	400/3/50+N	400/3/50+N	400/3/50+N	400/3/50+N	400/3/50+N	400/3/50+N	400/3/50+N	400/3/50+N

1. Entering/leaving water temperature user side 23/18°C, external exchanger entering air 35°C
2. The overall power absorbed is calculated by adding the power absorbed by the compressor + the power absorbed by the fan - the percentage value of the fan to overcome external pressure drop + the power absorbed by the pump - the percentage value of the pump to overcome pressure drop outside + the power absorbed by the auxiliary electrical circuit
3. EER (EN 14511:2013) cooling performance coefficient. Ratio between delivered cooling capacity and power input in compliance with EN 14511:2013
4. ESEER calculated by Clivet for radiant systems with water produced at 18°C by taking into account the load conditions and source water temperature as defined by EUROVENT for water at 7°C
5. User side entering/leaving water temperature 12/7 °C, external exchanger entering air 35°C
6. ESEER calculated by EUROVENT, for systems featuring terminal units with water produced at 7°C
7. PHE = plate exchanger
8. AX = axial fan

The heads are intended as available at the unit connections

The pressure drops of the steel mesh strainer, supplied with the unit, have been already taken into consideration

EXCELLENCE VERSION

General technical data

Size			21	31	41	51	71	81	91	101	121	131	141	151	161	171
Radiant panels																
Cooling																
Cooling capacity	1	kW	4,25	6,33	8,06	10,3	13,0	15,9	18,7	20,9	26,5	33,0	39,8	40,5	47,6	52,9
Total power input	2	kW	1,07	1,68	2,10	2,72	3,42	3,87	4,84	5,74	6,27	8,34	9,88	10,3	12,0	13,9
EER (EN 14511:2013)	3		3,97	3,77	3,85	3,80	3,81	4,12	3,86	3,65	4,23	3,96	4,03	3,92	3,97	3,80
ESEER	4		5,86	5,43	5,95	5,09	6,04	6,62	6,86	6,61	7,71	5,77	5,77	5,30	4,98	4,89
Water flow-rate	1	l/s	0,20	0,30	0,39	0,49	0,62	0,76	0,89	1,00	1,27	1,58	1,90	1,94	2,27	2,53
Useful pump discharge head	1	kPa	58	51	43	45	46	64	59	55	69	100	103	101	84	67
ELFORoom and ELFOSpace terminal units																
Cooling																
Cooling capacity	5	kW	4,40	5,65	8,00	10,2	13,1	15,5	17,4	19,6	25,3	26,8	32,4	36,4	43,2	48,1
Total power input	2	kW	1,58	2,04	2,91	3,78	5,12	5,18	6,26	7,83	8,69	8,56	10,2	12,2	14,4	16,4
EER (EN 14511:2013)	3		2,79	2,77	2,75	2,69	2,55	2,99	2,78	2,50	2,91	3,13	3,18	2,99	3,00	2,93
ESEER	6		4,42	4,09	4,43	4,28	4,76	5,18	5,13	4,90	5,71	4,18	4,27	3,88	3,80	3,75
Water flow-rate	5	l/s	0,21	0,27	0,38	0,49	0,63	0,74	0,83	0,94	1,21	1,28	1,55	1,74	2,06	2,30
Useful pump discharge head	5	kPa	57	53	43	45	45	64	62	58	72	124	122	112	98	83
Compressor																
Type of compressors			Rotary inverter dc				Scroll inverter DC									
Refrigerant			R-410A	R-410A	R-410A	R-410A	R-410A	R-410A	R-410A	R-410A	R-410A	R-410A	R-410A	R-410A	R-410A	R-410A
No. of compressors			1	1	1	1	1	1	1	1	1	1	1	1	1	1
Oil charge			0,35	0,35	0,87	1,70	1,70	1,90	1,90	1,90	1,90	1,90	3,30	3,30	3,60	3,60
Refrigeration circuits			1	1	1	1	1	1	1	1	1	1	1	1	1	1
Refrigerant Charge			2,1	1,9	2,1	3,3	4,4	4,7	4,7	4,7	6,8	6,8	6,8	10	10	10
User side exchanger																
Type of internal exchanger			PHE	PHE	PHE	PHE	PHE	PHE	PHE	PHE	PHE	PHE	PHE	PHE	PHE	PHE
No. of exchangers			1	1	1	1	1	1	1	1	1	1	1	1	1	1
Water content			0,56	0,64	0,64	1,14	1,80	2,37	2,37	2,37	3,13	3,13	3,13	3,13	4,27	4,27
External Section Fans																
Type of fans			AX	AX	AX	AX	AX	EC	EC	EC	EC	EC	EC	EC	EC	EC
No. of fans			1	1	1	2	2	1	1	1	2	1	1	1	1	1
Standard airflow			653	1028	1028	2081	1996	2222	2306	2444	2778	4694	4694	5139	5649	5833
Installed unit power			0,12	0,15	0,15	0,15	0,15	0,19	0,23	0,27	0,20	0,63	0,63	1,03	1,02	1,36
Water circuit																
Maximum water side pressure			550	550	550	550	550	550	550	550	550	550	550	550	550	550
Safety valve calibration			600	600	600	600	600	600	600	600	600	600	600	600	600	600
Min. installation water contents			17	20	25	33	40	50	53	57	63	68	87	99	113	117
Power supply																
Standard power supply			230/1/50	230/1/50	230/1/50	400/3/50+N	400/3/50+N	400/3/50+N	400/3/50+N	400/3/50+N	400/3/50+N	400/3/50+N	400/3/50+N	400/3/50+N	400/3/50+N	400/3/50+N

1. Entering/leaving water temperature user side 23/18°C, external exchanger entering air 35°C
2. The overall power absorbed is calculated by adding the power absorbed by the compressor + the power absorbed by the fan - the percentage value of the fan to overcome external pressure drop + the power absorbed by the pump - the percentage value of the pump to overcome pressure drop outside + the power absorbed by the auxiliary electrical circuit
3. EER (EN 14511:2013) cooling performance coefficient. Ratio between delivered cooling capacity and power input in compliance with EN 14511:2013
4. ESEER calculated by Clivet for radiant systems with water produced at 18°C by taking into account the load conditions and source water temperature as defined by EUROVENT for water at 7°C
5. User side entering/leaving water temperature 12/7 °C, external exchanger entering air 35°C
6. ESEER calculated by EUROVENT, for systems featuring terminal units with water produced at 7°C
7. PHE = plate exchanger
8. AX = axial-flow fan, EC = axial-flow fan + EC

The heads are intended as available at the unit connections

The pressure drops of the steel mesh strainer, supplied with the unit, have been already taken into consideration

Sound levels PREMIUM VERSION

Size	Sound power level								Sound pressure level	Sound power level
	Octave band (Hz)									
	63	125	250	500	1000	2000	4000	8000	dB(A)	dB(A)
21	73	73	70	65	63	59	51	36	49	64
31	76	70	65	60	58	53	46	48	49	64
41	76	71	66	61	59	54	47	49	49	64
51	76	71	69	66	63	58	50	39	53	68
71	77	71	69	67	63	59	50	40	54	69
81	83	77	69	61	63	67	60	61	56	72
91	84	79	70	62	64	67	60	61	56	72
101	86	81	72	62	65	67	60	61	57	73
121	81	73	67	61	63	67	61	61	55	71
131	85	76	70	61	64	67	61	61	56	72
141	86	79	72	63	65	68	61	62	57	73

Sound levels refer to units with full load under nominal test conditions.

The sound pressure level refers to a distance of 1m from the outer surface of the unit operating in an open field.

Noise levels are determined using the tensiometric method (UNI EN ISO 9614-2)

Data referred to the following conditions:

- internal exchanger water = 12/7 °C

- Ambient temperature = 35 °C

Sound levels EXCELLENCE VERSION

Size	Sound power level								Sound pressure level	Sound power level
	Octave band (Hz)									
	63	125	250	500	1000	2000	4000	8000	dB(A)	dB(A)
21	73	73	70	65	63	59	51	36	49	64
31	76	70	65	60	58	53	46	48	49	64
41	76	71	66	61	59	54	47	49	49	64
51	76	71	69	66	63	58	50	39	53	68
71	77	71	69	67	63	59	50	40	54	69
81	83	77	69	61	63	67	60	61	56	72
91	84	79	70	62	64	67	60	61	56	72
101	86	81	72	62	65	67	60	61	57	73
121	81	73	67	61	63	67	61	61	55	71
131	85	83	75	70	78	69	63	64	63	80
141	85	83	80	79	83	75	72	61	69	85
151	88	86	81	80	84	75	72	61	70	86
161	93	91	85	85	87	78	75	65	73	89
171	94	84	85	85	87	78	75	65	73	90

Sound levels refer to units with full load under nominal test conditions.

The sound pressure level refers to a distance of 1m from the outer surface of the unit operating in an open field.

Noise levels are determined using the tensiometric method (UNI EN ISO 9614-2)

Data referred to the following conditions:

- internal exchanger water = 12/7 °C

- Ambient temperature = 35 °C

Admissible water flow rates

Size		21	31	41	51	71	81	91	101	121	131	141	151	161	171
Minimum flow	[l/s]	0,15	0,18	0,18	0,23	0,34	0,35	0,35	0,35	0,42	0,42	0,42	0,42	0,48	0,48
Maximum flow-rate	[l/s]	0,90	0,90	0,90	1,10	1,50	1,95	1,95	1,95	2,70	2,70	2,70	2,70	2,70	2,70

Operating range

Cooling

ELFOEnergy Extended Inverter 21 - 31 - 41 - EXCELLENCE/PREMIUM

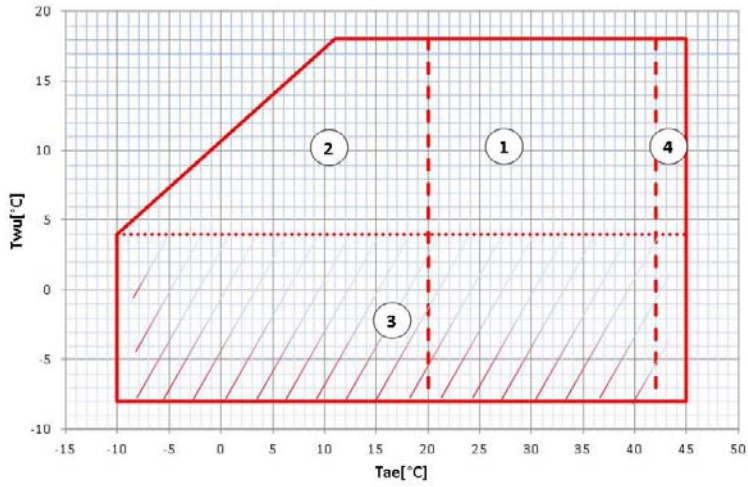

ELFOEnergy Extended Inverter 51-141 - PREMIUM, 51-131 EXCELLENCE

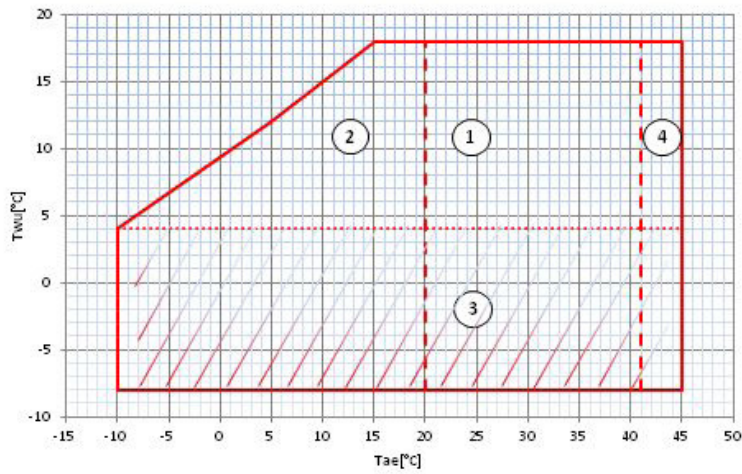

ELFOEnergy Extended Inverter 141-171 - EXCELLENCE

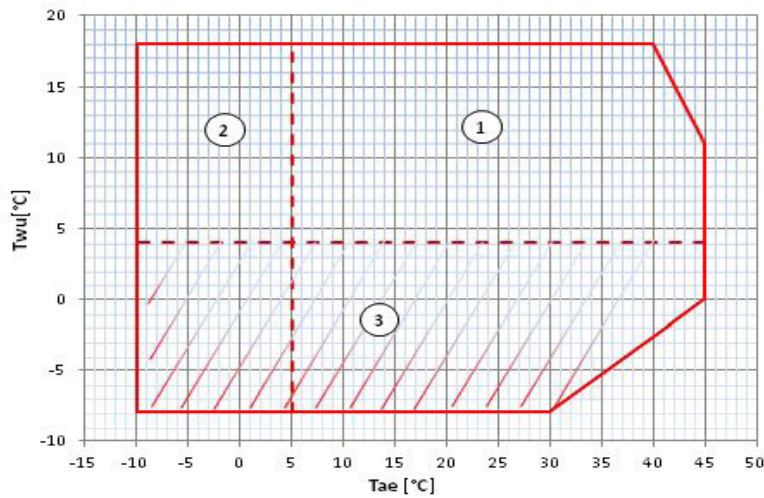

T_{wu} [°C] = leaving exchanger water temperature
 T_{ae} [°C]: external exchanger inlet air temperature

1. Normal operating range
2. Normal operating range with modulating fans
3. Operating range where the use of ethylene glycol is mandatory in relation to the temperature of the water at the outlet of the user side exchanger
4. Operating range with modulating compressor

Dimensional drawings - PREMIUM Version

ELFOEnergy Extended Inverter 51-71

DABQ951 REV00
24/11/2014

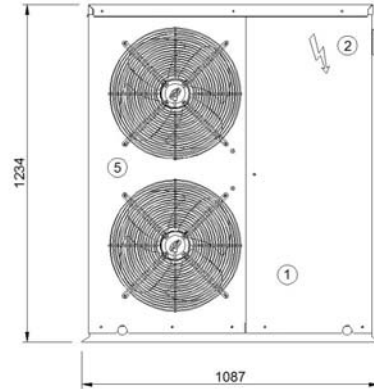
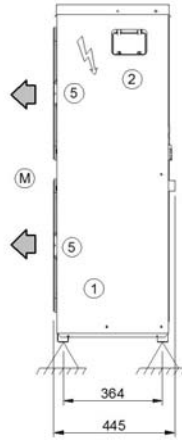
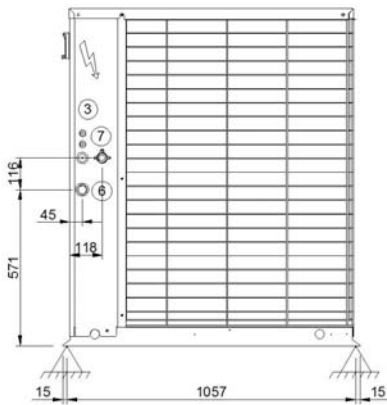

- 1. Compressor compartment
- 2. Electrical panel
- 3. Power input
- 4. Functional spaces
- 5. Electric fan (Supply)
- 6. internal exchanger water inlet (GAS F 1")
- 7. internal exchanger water outlet (GAS F 1")
- (M) Air supply

Size		51	71
Length	mm	1087	1087
Depth	mm	445	445
Height	mm	1234	1234
W1	kg	51	53
W2	kg	32	33
W3	kg	53	55
W4	kg	34	34
Operating weight	kg	170	175
Shipping weight	kg	172	177

The presence of optional accessories may result in a substantial variation of the weights shown in the table.

Dimensional drawings - PREMIUM Version

ELFOEnergy Extended Inverter 81-91-101

DABQ981 REV00
24/11/2014

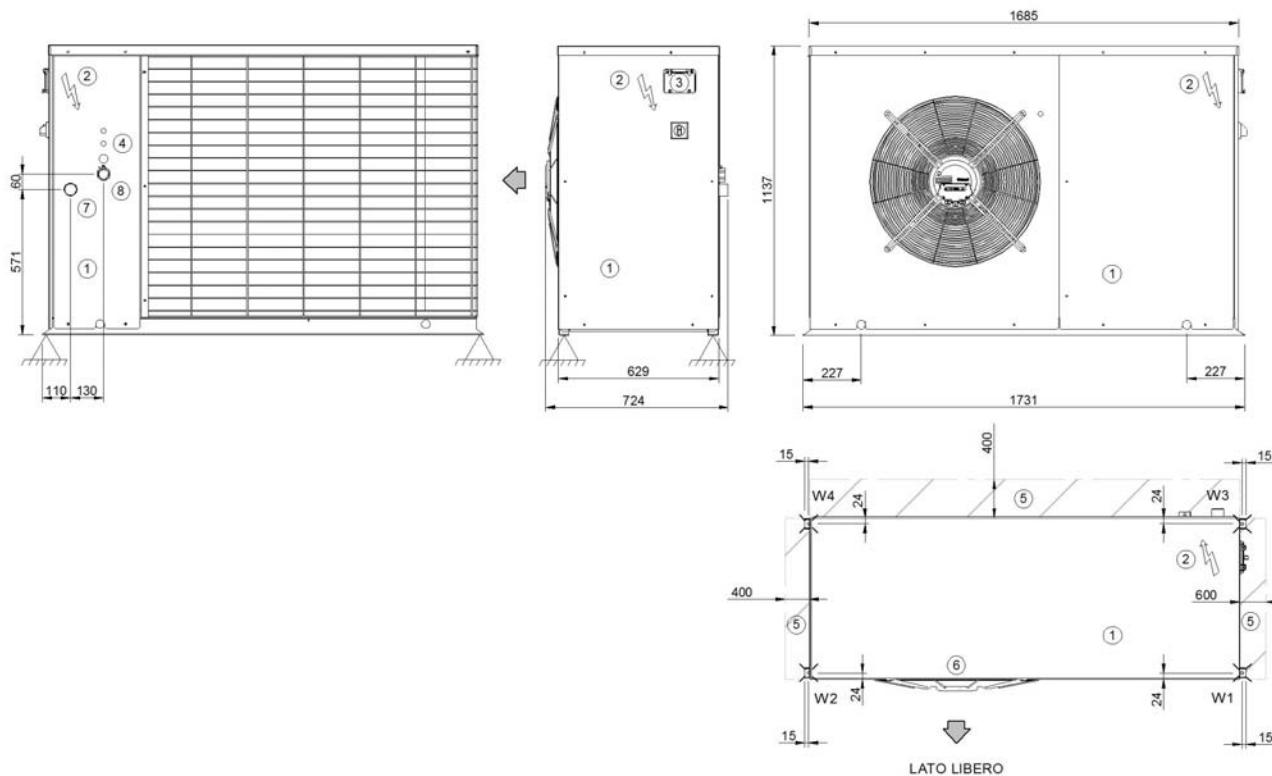

- 1. Compressor compartment
 - 2. Electrical panel
 - 3. Unit control keypad
 - 4. Power input
 - 5. Functional spaces
 - 6. Electric fan (supply - return)
 - 7. Internal exchanger water inlet (GAS F 1 1/4")
 - 8. Internal exchanger water outlet (GAS F 1 1/4")
- (M) Air supply

Size			81	91	101
Length		mm	1731	1731	1731
Depth		mm	724	724	724
Height		mm	1137	1137	1137
W1		kg	65	65	65
W2		kg	35	35	35
W3		kg	85	85	85
W4		kg	55	55	55
Operating weight		kg	240	240	240
Shipping weight		kg	250	250	250

The presence of optional accessories may result in a substantial variation of the weights shown in the table.

Dimensional drawings - PREMIUM Version

ELFOEnergy Extended Inverter 121 - 131 - 141

DABQ9121 REV01
03/11/2015

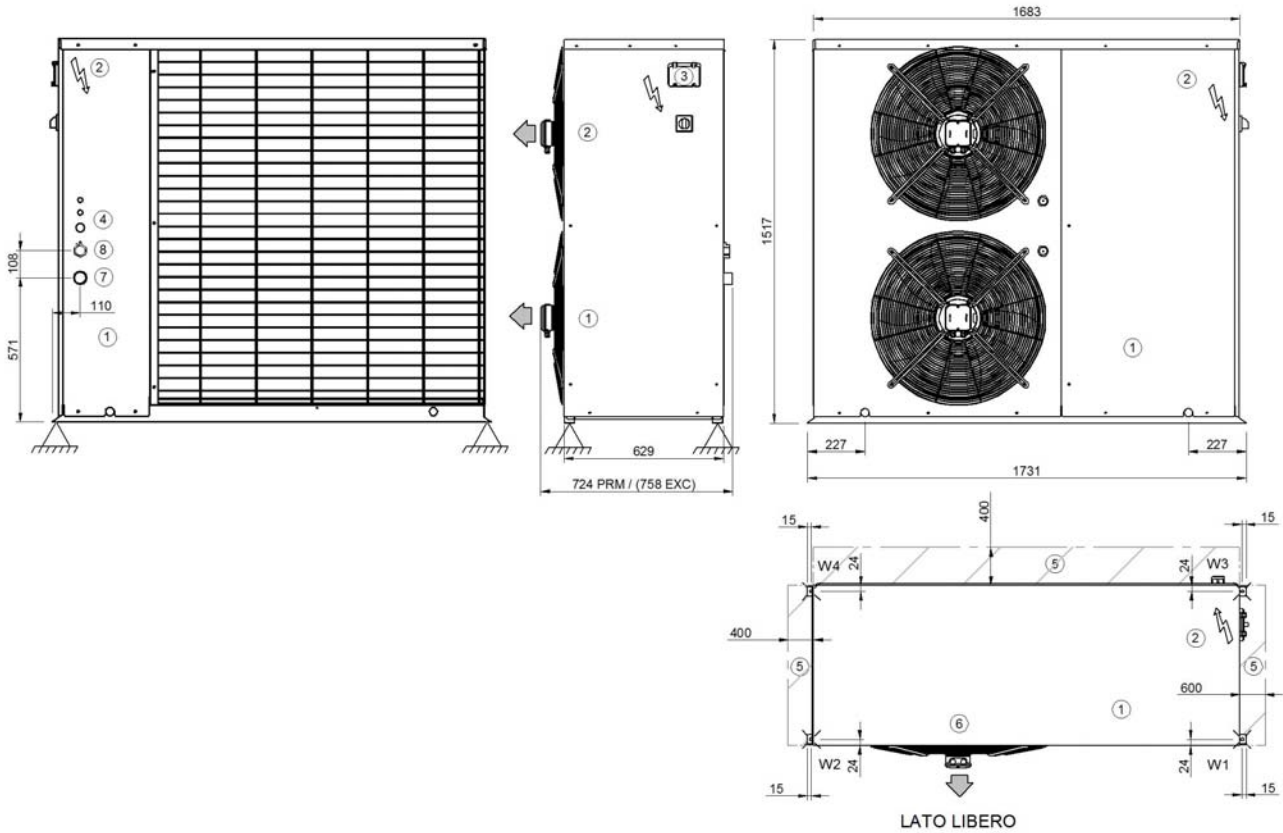

- 1. Compressor compartment
- 2. Electrical panel
- 3. Unit control keypad
- 4. Power input
- 5. Functional spaces
- 6. Electric fan (supply - return)
- 7. Internal exchanger water inlet (GAS F 1 1/4")
- 8. Internal exchanger water outlet (GAS F 1 1/4")
- (M) Air supply

Size			121	131	141
Length		mm	1731	1731	1731
Depth		mm	724	724	724
Height		mm	1517	1517	1517
W1		kg	65	65	65
W2		kg	35	35	35
W3		kg	85	85	85
W4		kg	55	55	55
Operating weight		kg	240	240	240
Shipping weight		kg	250	250	250

The presence of optional accessories may result in a substantial variation of the weights shown in the table.

Dimensional drawings - EXCELLENCE Version

ELFOEnergy Extended Inverter 21 - 31 - 41

DABQ921 REV00
24/11/2014

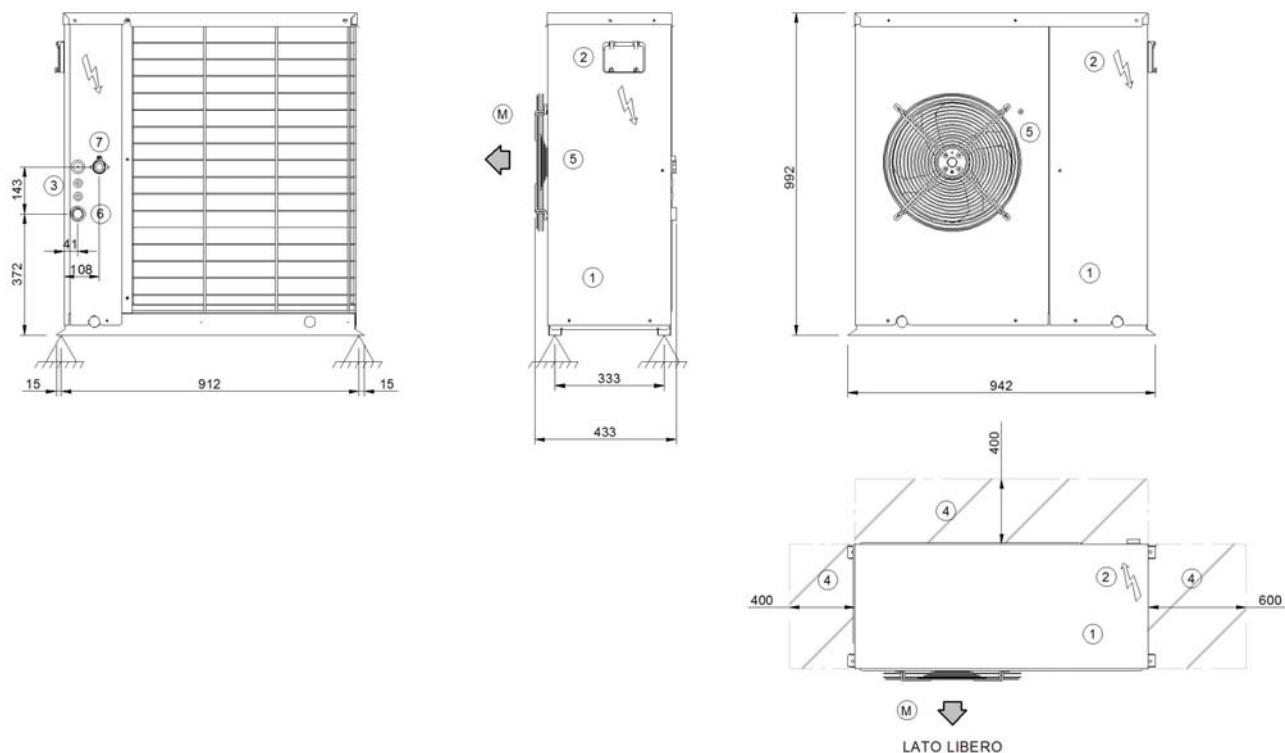

- 1. Compressor compartment
 - 2. Electrical panel
 - 3. Power input
 - 4. Functional spaces
 - 5. Electric fan (Supply)
 - 6. internal exchanger water inlet (GAS F 1")
 - 7. internal exchanger water outlet (GAS F 1")
- (M) Air supply

Size		21	31	41
Length	mm	942	942	942
Depth	mm	433	433	433
Height	mm	992	992	992
W1	kg	37	38	40
W2	kg	17	18	20
W3	kg	39	40	42
W4	kg	19	20	22
Operating weight	kg	112	116	124
Shipping weight	kg	114	118	126

The presence of optional accessories may result in a substantial variation of the weights shown in the table.

Dimensional drawings - EXCELLENCE Version

ELFOEnergy Extended Inverter 51 - 71

DABQ951 REV00
24/11/2014

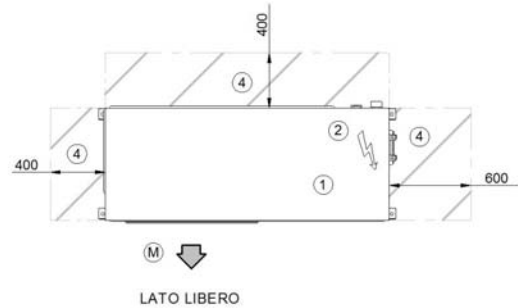
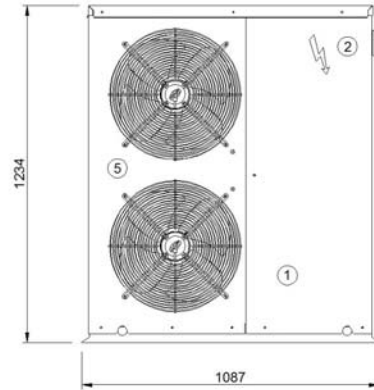
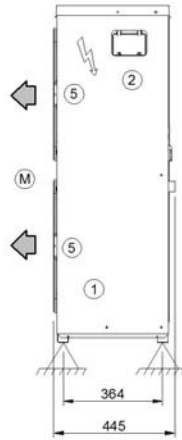
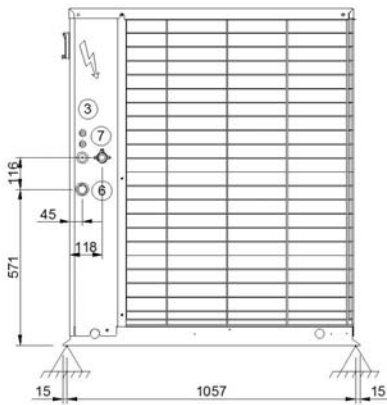

- 1. Compressor compartment
 - 2. Electrical panel
 - 3. Power input
 - 4. Functional spaces
 - 5. Electric fan (Supply)
 - 6. internal exchanger water inlet (GAS F 1")
 - 7. internal exchanger water outlet (GAS F 1")
- (M) Air supply

Size		51	71
Length	mm	1087	1087
Depth	mm	445	445
Height	mm	1234	1234
W1	kg	51	53
W2	kg	32	33
W3	kg	53	55
W4	kg	34	34
Operating weight	kg	170	175
Shipping weight	kg	172	177

The presence of optional accessories may result in a substantial variation of the weights shown in the table.

Dimensional drawings - EXCELLENCE Version

ELFOEnergy Extended Inverter 81 - 91 - 101

DABQ981 REV00
24/11/2014

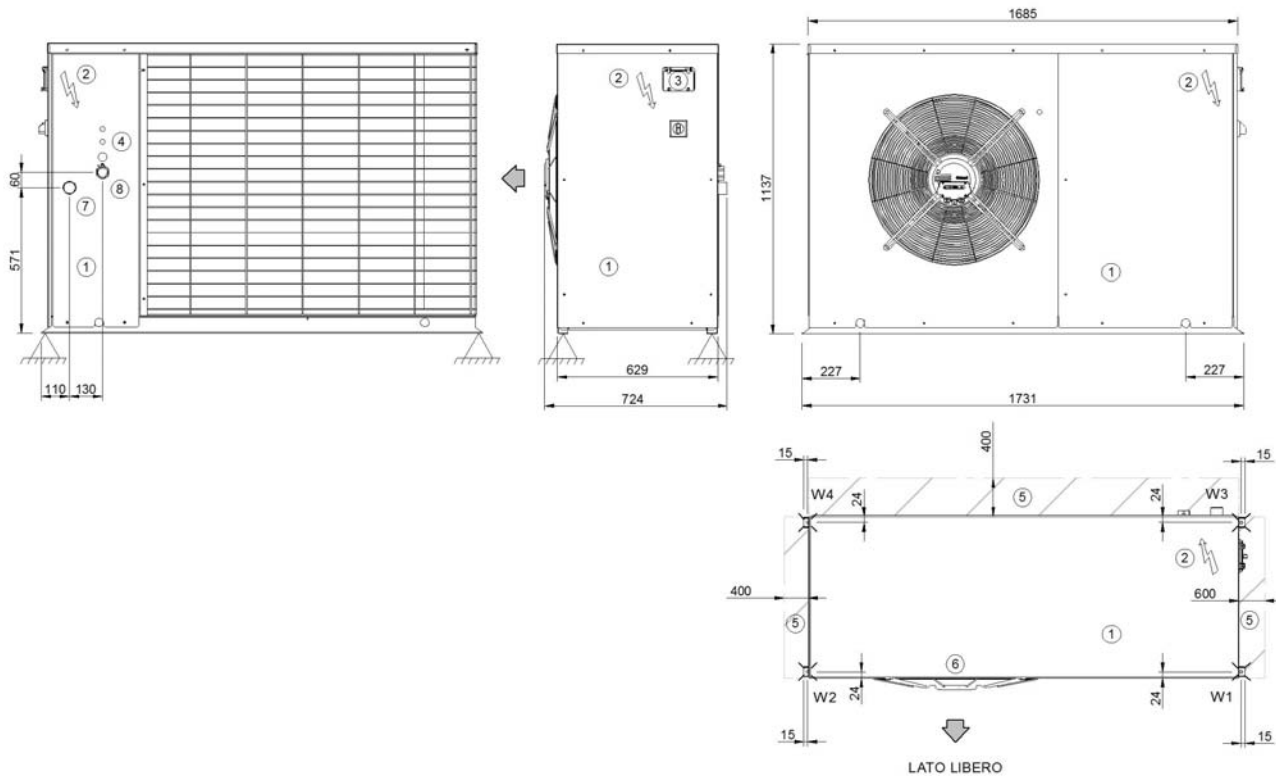

- 1. Compressor compartment
 - 2. Electrical panel
 - 3. Unit control keypad
 - 4. Power input
 - 5. Functional spaces
 - 6. Electric fan (supply - return)
 - 7. Internal exchanger water inlet (GAS F 1 1/4")
 - 8. Internal exchanger water outlet (GAS F 1 1/4")
- (M) Air supply

Size			81	91	101
Length		mm	1731	1731	1731
Depth		mm	724	724	724
Height		mm	1137	1137	1137
W1		kg	65	65	65
W2		kg	35	35	35
W3		kg	85	85	85
W4		kg	55	55	55
Operating weight		kg	240	240	240
Shipping weight		kg	250	250	250

The presence of optional accessories may result in a substantial variation of the weights shown in the table.

Dimensional drawings - EXCELLENCE Version

ELFOEnergy Extended Inverter 121

DABQ9121 REV01
03/11/2015

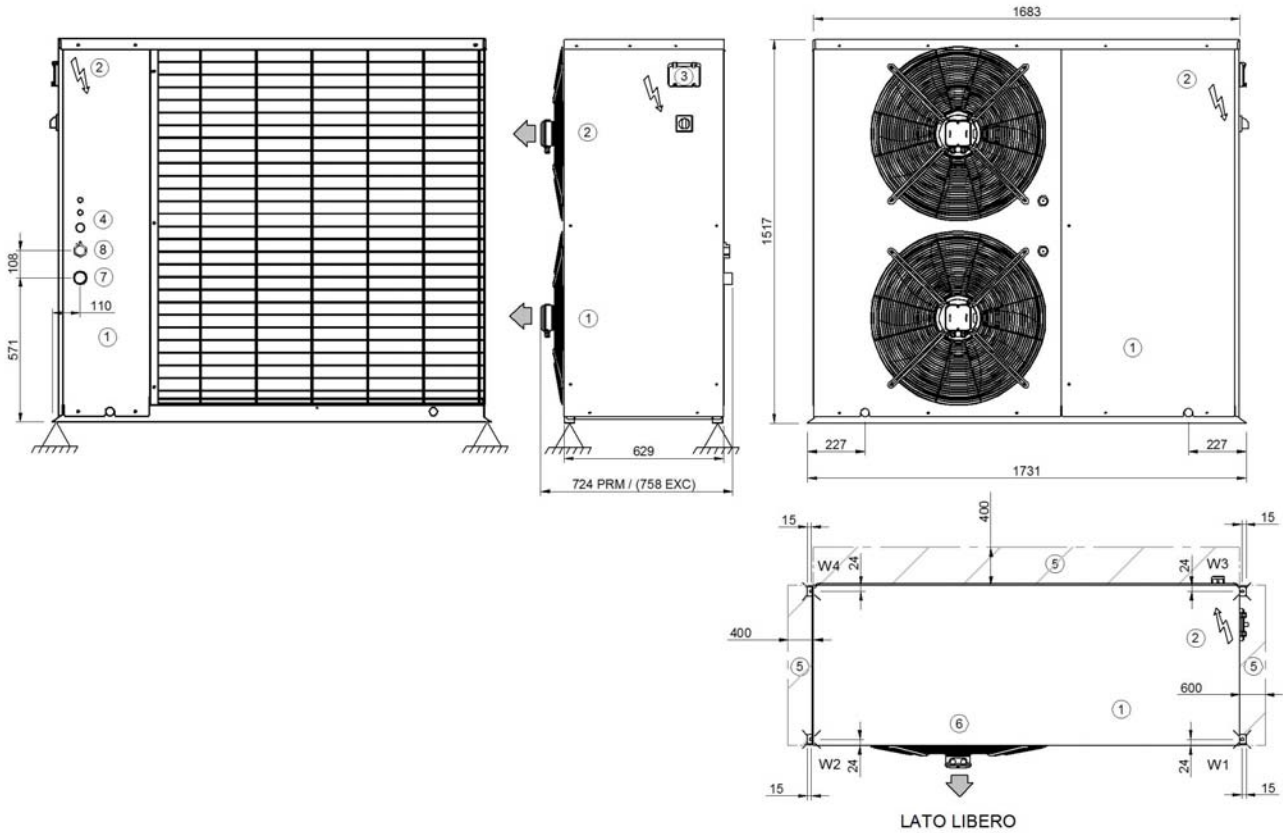

- 1. Compressor compartment
 - 2. Electrical panel
 - 3. Unit control keypad
 - 4. Power input
 - 5. Functional spaces
 - 6. Electric fan (supply - return)
 - 7. Internal exchanger water inlet (GAS F 1 1/4")
 - 8. Internal exchanger water outlet (GAS F 1 1/4")
- (M) Air supply

Size	121		
Length		mm	1731
Depth		mm	724
Height		mm	1517
W1		kg	70
W2		kg	55
W3		kg	110
W4		kg	75
Operating weight		kg	310
Shipping weight		kg	320

The presence of optional accessories may result in a substantial variation of the weights shown in the table.

Dimensional drawings - EXCELLENCE Version

ELFOEnergy Extended Inverter 131 - 141 - 151

DABQ9131_151_1 REV01
21/10/2014

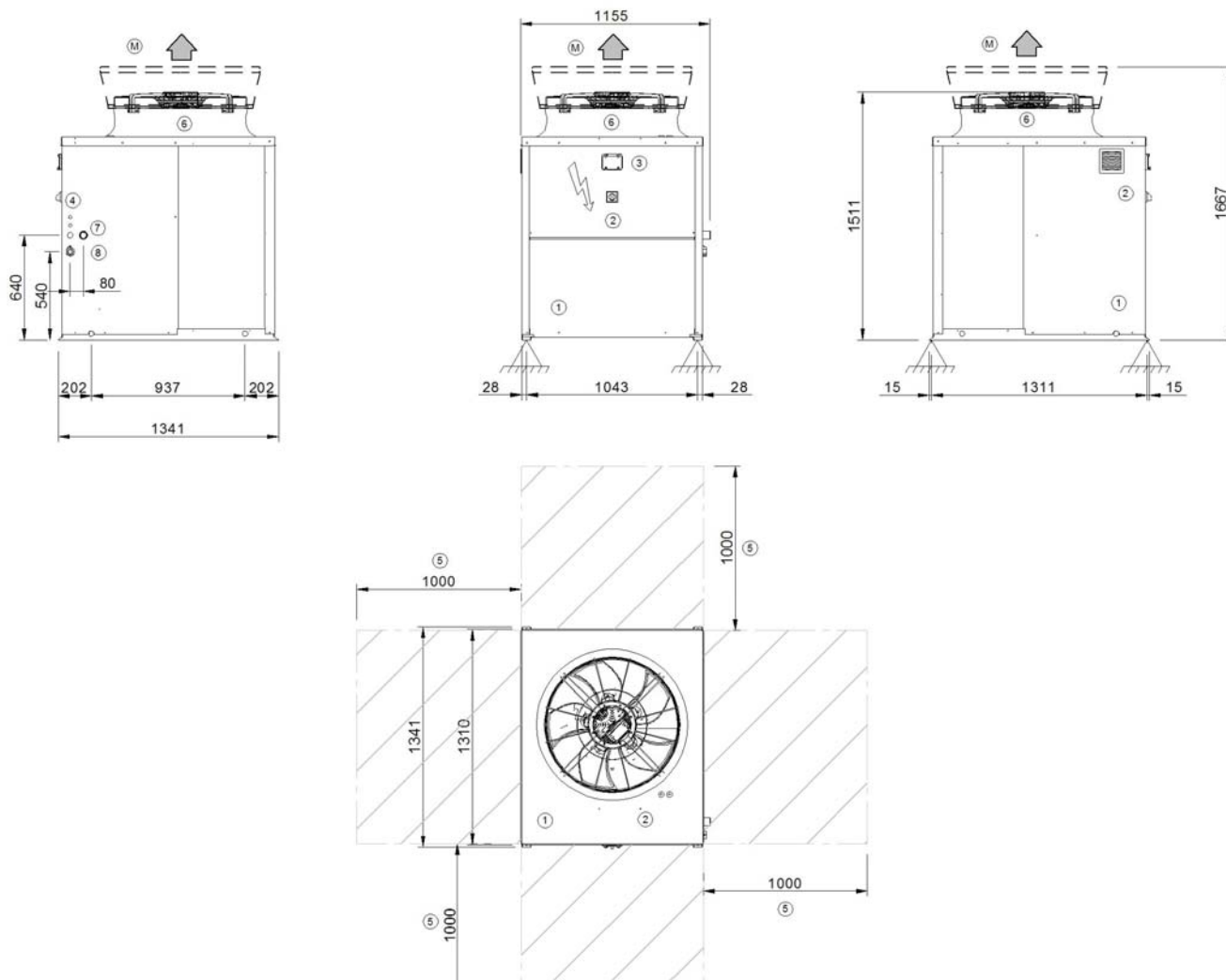

- 1. Compressor compartment
- 2. Electrical panel
- 3. Unit control keypad
- 4. Power input
- 5. Functional spaces
- 6. Electric fan (supply - return)
- 7. Internal exchanger water inlet (GAS F 1 1/4")
- 8. Internal exchanger water outlet (GAS F 1 1/4")
- (M) Air supply

Size			131	141	151
Length		mm	1341	1341	1341
Depth		mm	1159	1159	1159
Height		mm	1520	1520	1520
Operating weight		kg	290	300	320
Shipping weight		kg	300	310	330

The presence of optional accessories may result in a substantial variation of the weights shown in the table.

Dimensional drawings - EXCELLENCE Version

ELFOEnergy Extended Inverter 161 - 171

DABQ9161_171_1 REV01
Data: 21/10/2014

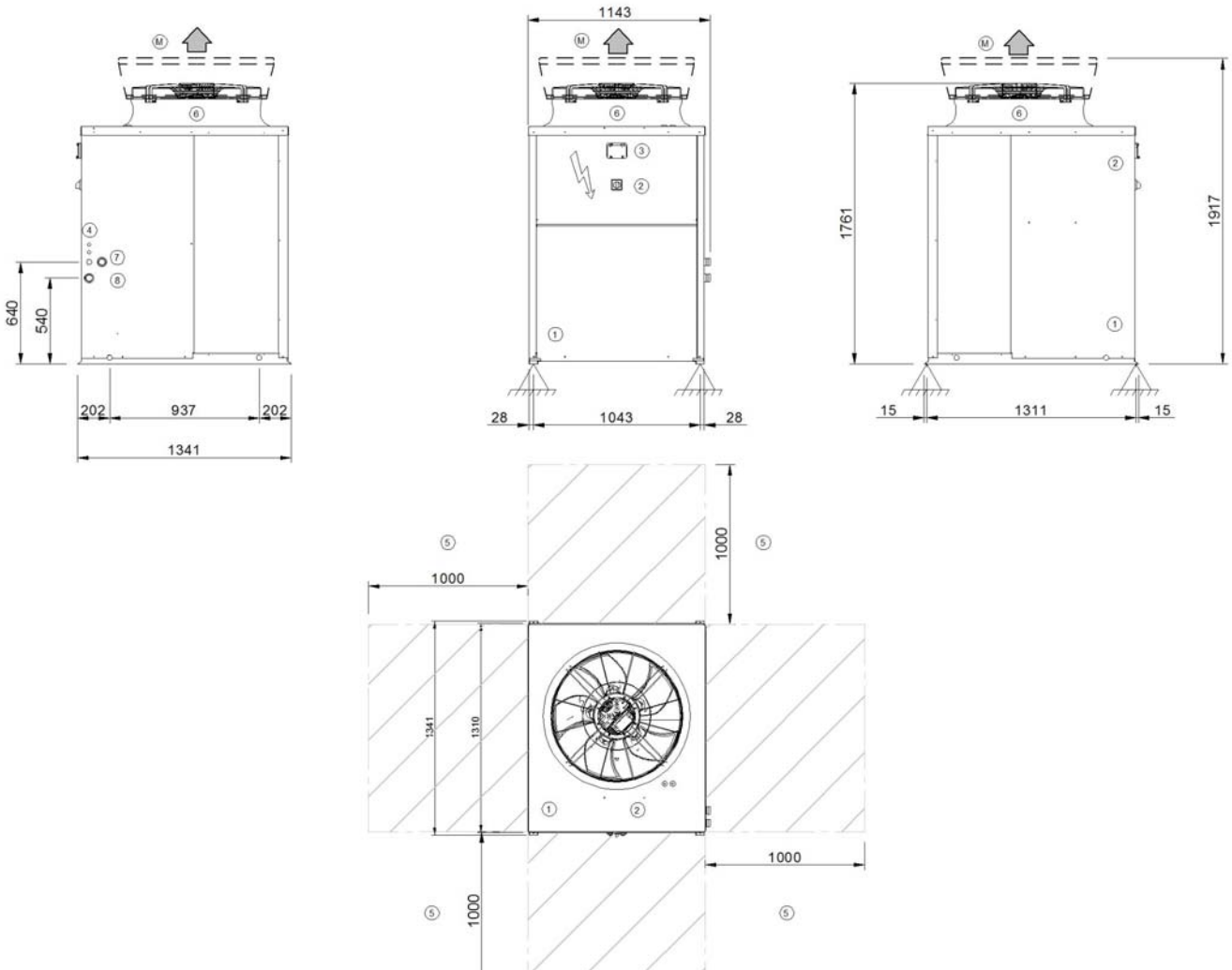

1. Compressor compartment
2. Electrical panel
3. Unit control keypad
4. Power input
5. Functional spaces
6. Electric fan (supply - return)
7. Internal exchanger water inlet (GAS Victaulic1" 1/2)
8. Internal exchanger water outlet (GAS Victaulic1" 1/2)

(M) Air supply

Size			161	171
Length		mm	1341	1341
Depth		mm	1146	1146
Height		mm	1770	1770
Operating weight		kg	390	390
Shipping weight		kg	400	400

The presence of optional accessories may result in a substantial variation of the weights shown in the table.

**CLIVET SPA**

Via Camp Lonc 25, Z.I. Villapaiera - 32032 Feltre (BL) - Italy
Tel. + 39 0439 3131 - Fax + 39 0439 313300 - info@clivet.it

CLIVET UK LTD (Sales)

4 Kingdom Close, Segensworth East - Fareham, Hampshire - PO15 5TJ - United Kingdom
Tel. + 44 (0) 1489 572238 - Fax + 44 (0) 1489 573033 - info@clivet-uk.co.uk

CLIVET AIRCON LTD (Service and Maintenance Division)

Units F5&F6 Railway Triangle Ind Est, Walton Road - Portsmouth, Hampshire - PO6 1TG - United Kingdom
Tel. +44 (0) 2392 381235 - Fax. +44 (0) 2392 381243 - info@clivetaircon.co.uk

CLIVET ESPAÑA COMERCIAL S.L. (Sales)

Calle Gurb, 17 1º 1ª - 08500 Vic, Barcelona - España
Tel: +34 93 8606248 - Fax +34 93 8855392 - info@clivetcomercial.com

CLIVET ESPAÑA S.A.U. (Service and Maintenance Division)

Calle Real de Burgos Nº 12 - 28860 Paracuellos del Jarama, Madrid - España
Tel. +34 91 6658280 - Fax +34 91 6657806 - info@clivet.es

CLIVET GmbH

Hummelsbütteler Steindamm 84, 22851 Norderstedt - Germany
Tel. + 49 (0) 40 32 59 57-0 - Fax + 49 (0) 40 32 59 57-194 - info.de@clivet.com

CLIVET RUSSIA

Elektrozavodskaya st. 24, office 509 - 107023, Moscow, Russia
Tel. + 74956462009 - Fax + 74956462009 - info.ru@clivet.com

CLIVET MIDEAST FZCO

Dubai Silicon Oasis (DSO), High Bay Complex, Ind Unit No. 3, PO BOX 342009, Dubai, UAE
Tel. + 9714 3208499 - Fax + 9714 3208216 - info@clivet.ae

CLIVET AIRCONDITIONING SYSTEMS PRIVATE LIMITED

4BA, Gundecha Onclave - Kherani Road, Saki Naka, Andheri (East) - Mumbai 400 072 - India
Tel. +91 22 6193 7000 - Fax +91 22 6193 7001 - info.in@clivet.com