

SYSCROLL 20-30 AIR EVO

Air Cooled Inverter Driven Water Heat Pump
Engineering Data Manual



20.0 to 35.0 kW

20.0 to 34.0 kW



Key points

- Wide **load variation capability**.
 - Cooling operation → down to 30 % and up to 140% of nominal capacity.
 - Heating operation → down to 40% and up to 130% of nominal capacity.
- Great **accuracy in maintaining desired set-point**.
- Unit **optimization for heating operation** both for fan coil and floor application.
- Excellent **efficiency performances** both at **full** and **partial load** (EER/COP/SEER/SCOP).
- Wide **operating limits** in heating mode:
 - Min outdoor ambient temperature → -15 [°C].
 - Max leaving water temperature → 55 [°C].
- Simple refrigerant circuit with **easy access** to inner components for maintenance purpose.
- **Aerulic independence** between refrigerant circuit and condensing side.
- New **fan motors** (Erp 2015 compliant) with integrated grill, nozzle and condensers.
- Possibility to manage domestic hot water production, auxiliary heating source, second set-point zone field components

- Several **options / accessories provided** with standard delivery:
 - Fan speed control → cooling operation with low OAT / heating operation with high OAT.
 - Electronic expansion valve → precision in SH control.
 - ModBus interface → supervision ready.
 - Phase sequence control algorithm → safe electric installation.
 - Modulating capacity control → precision in water set-point control.
 - Soft-start function → low inrush current.
 - Power factor correction function → low input current distortion.
 - Coil blue fin treatment → effective water drainage during defrost.
 - Coil guard → protection during transport and installation.
 - Double set-point → different daily profiles.
 - Dynamic set-point → water profile in accordance with outdoor air temperature or current / voltage signal.
 - Water filter → protection against impurities.
 - Water differential pressure switch → protection against low water flow.
 - Rubber pads → basic vibration attenuation.

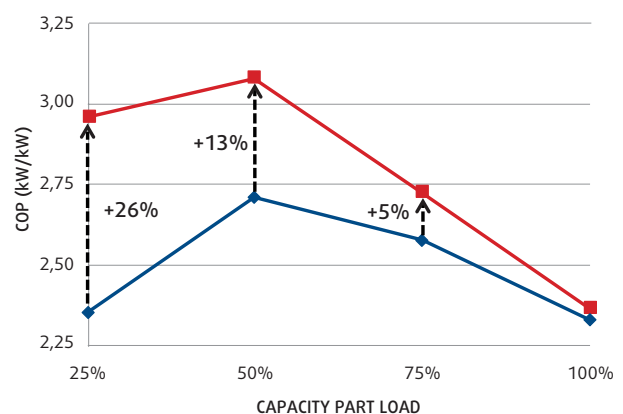
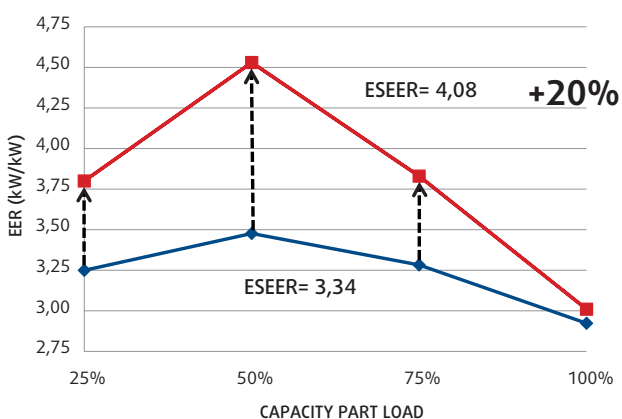

—●— FIXED SPEED —■— VARIABLE SPEED

Comparison between fixed speed and variable speed technology - Cooling operation

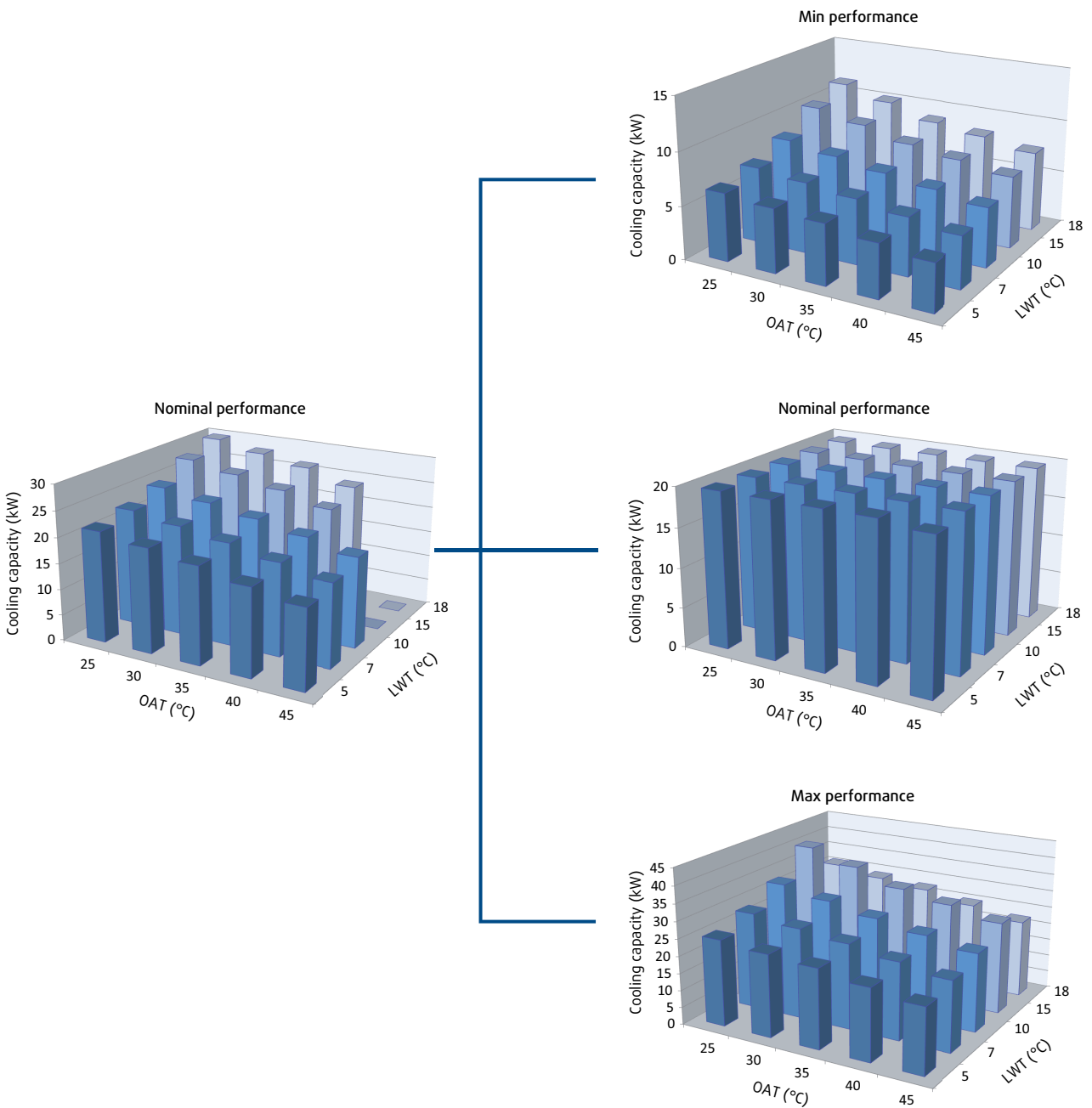

Comparison between fixed speed and variable speed technology - Heating operation

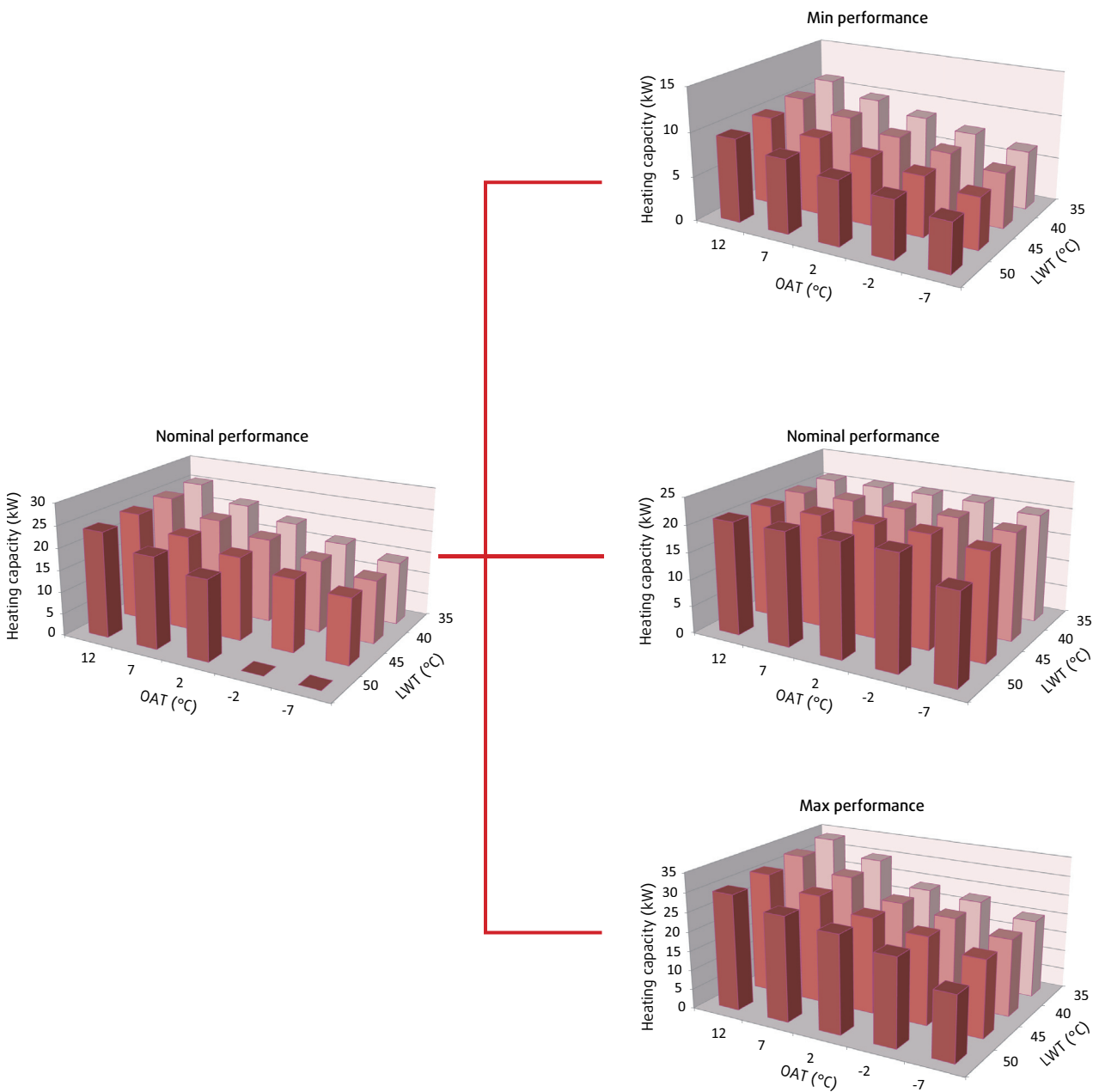

Specifications

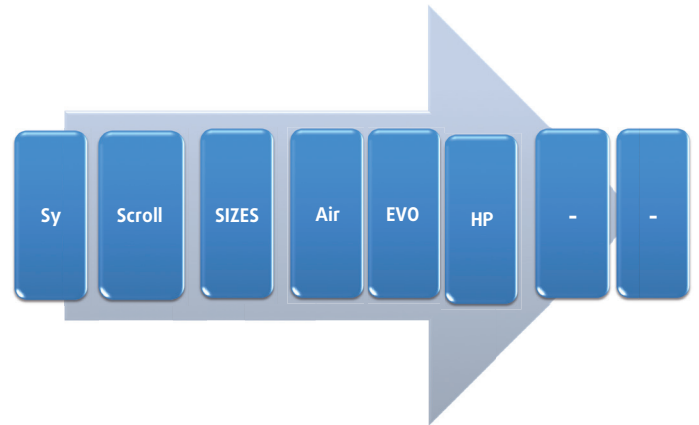

HP = Heat Pump; Version - = BLN.

General

SYSCROLL AIR EVO air cooled water heat pumps have been designed and optimized to operate with R410A refrigerant and **inverter driven scroll compressors**.

Thanks to inverter technology it is possible to cover with only **2 sizes** a very **wide capacity range** both in cooling (from **20 to 35 kW**) and heating (from **20 to 34 kW**) operation.

All units are equipped with a single inverter driven 3-phase **scroll compressor**.

The general operation status of the unit is steadily managed by a microprocessor implementing a **dedicated developed software**, allowing operation with a very **low water content** (2,5 l/kW) and ensuring a total protection of compressor inside its operating envelope.

An external **buffer tank** can be supplied as accessory for field installation; it is mainly recommended to provide compensation to water temperature decrease occurring during defrost operation.

The units can be equipped with an optional inverter driven **multistage centrifugal pump**.

Conformity with standards

The units are in conformity with the following standards:

- Machinery Directive: 2006/42/EC
- Electromagnetic Compatibility Directive: 2014/30/UE
- Pressure Equipment Directive: 2014/68/UE
- Ecodesign Directive: 2009/125/EC

Cabinet

The cabinet is made of heavy gauge galvanized steel.

All galvanized steel components are individually painted by a special painting process before the assembly of the unit. This painting system performs a homogeneous protection to the corrosion. The painting is a polyester powder based type, coloured in **RAL 7040** as standard. The units are suitable for outdoor installation, directly on the building roof or at the ground level.

Compressors

Compressors are **hermetic scroll** equipped with **brushless direct current motor** (BLDC) type.

Motor is cooled down by refrigerant gas itself; a discharge gas thermostat and a discharge temperature sensor protect motor against over-temperature operation.

A 40 W belt electric heater is switched ON during compressor OFF time in order to protect against flooded starts. Compressors are assembled on rubber shock absorbers to limit vibrations transmission.

Evaporator

Indoor heat exchangers are brazed stainless steel plate type. They are insulated with a 10 mm thick closed cell polyethylene foam material and provided with male gas threaded connections.

They are protected by a **35 W antifreeze electric heater** to ensure a good protection against freezing at low ambient temperature when the unit is switched off.

Maximum working pressure is 10 bar at water side and 45 bar at refrigerant side.

Air cooled condenser coil

Outdoor heat exchanger is **finned tube** coil. Coils are built with internally grooved copper tubes expanded into corrugated aluminium fins. Fin **pitch** and **blue fin hydrophilic treatment** are intended to optimize coil behaviour during heating and defrost operations.

Condenser fans

Units are equipped with two 500 mm diameter axial fans with profiled, sickle shaped blades designed with bionical know how, optimized full bellmouth with static blades (motor suspension) and short diffusor.

They are placed directly in front of the coil in order to increase the air flow and the heat transfer between air and refrigerant.

Fan motors have IP54 protection grade, and thermostat protection placed in the bearings. Both fans are equipped with a safety grill.

Refrigerant circuit

Refrigerant circuit is equipped with one hermetic scroll compressor, 4-way reversing valve, bi-flow filter drier, sight glass, bi-flow electronic expansion valve, liquid receiver and suction accumulator.

Hydraulic circuit

The units can be equipped with an optional inverter driven multi-stage centrifugal pump providing outdoor available static pressure. Pump impeller is insulated with anti-condensation shell. Water filter is supplied as standard. Safety valve and expansion tank are placed on suction side of the pump. Water connections are 1" 1/4 male GAS threaded type.

Control panel



A new optimized control with a simple user keyboard, manage unit operation under different load and temperature condition and protect compressor against operation out of its envelope.

In addition to standard features - as water temperature control - the control can also manage following functions:

- Dynamic set point with OAT compensation or current / voltage input signal,
- Double set point,
- Advanced pump management,
- Counting of pump / compressors operating hours,
- Display of discharge and suction pressure values,
- Display of temperature sensors,
- History of stored alarms.

Safety and control devices

Each unit has complete with the following safety and control devices.

Safety

- Fans motor overload protection,

- Compressor motor overload protection,
- Phase sequence control,
- Pump motor overload protection,
- High pressure switch,
- Low pressure switch,
- Discharge gas thermostat,
- Evaporator antifreeze electric heater,
- Crankcase oil electric heater.

Control

- Return water temperature sensor,
- Leaving water temperature sensor,
- Coil temperature sensor,
- Suction and discharge temperature sensors,
- Air temperature sensor,
- Suction and discharge pressure transducers.

Standard equipment

- Fan speed control.
- Electronic expansion valve.
- ModBus protocol kit for BMS.
- Phase sequence control function.
- Modulating capacity control.
- Coil blue fin treatment.
- Coil guard.
- Double set-point.
- Dynamic set-point.
- Water filter.
- Water differential pressure switch.
- Evaporator antifreeze electric heater.
- Compressor belt electric heater.

Factory-installed options

- Inverter driven multistage centrifugal pump.

Field-installed accessories

- Water buffer tank (112 l),
- Water flow switch,
- Water pressure switch,
- In/out valve kit,
- No pump kit,
- Remote ON/OFF control,
- Remote keyboard panel,
- Domestic hot water kit,
- Auxiliary heater kit,
- Second set-point zone kit.

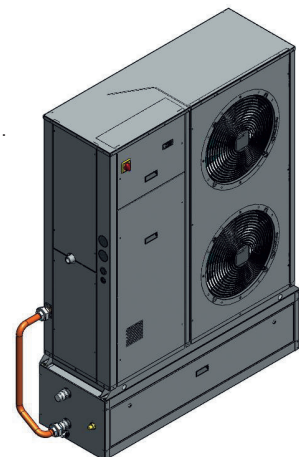

Accessories & Options

SYSCROLL AIR EVO	Delivery	Abbreviation	Description & Benefit
Phases sequence	Std	PHC	It allows to check the correct sense R-S-T of electric supply phases for 400/3/50 units.
Main switch	Std		Front operated switch-disconnector with direct mounted handle to cut the power Supply Line according CE standards.
Differential pressure switch	Std		Prevents the operation of the unit if the circulating chilled fluid is insufficient, by checking water differential pressure.
Antifreeze electric heater kit	Std	EEH	Electrical Heater protects the plate exchanger.
Low ambient kit (pressostatic modulating fan speed control)	Std	FSC	Electronic speed controllers are designed to control the speed of fan motors in Air Cooled Chiller and Heat pump. Fan Speed controlled by Condensing Pressure in cool mode or by Air Temp in heat mode. Using variable fan speed controllers offers following benefits in commercial refrigeration or air-conditioning applications: High Efficiency, Low Noise level, Low air temperature in cool mode and High air temperature in heat mode.
Double set point	Std	DSP	Can manage two different setpoints selected by remote dry contact.
Electronic expansion valve	Std	EEV	It is the device able to control the refrigerant flow on suction line through a stepper motor in order to keep the superheat as constant as possible.
Modbus protocol kit for BMS	Std	MBS	It permits the integration of the unit with Modbus protocol through RS485 port.
Coil Guards	Std	CG	Grilles to protect the coils.
Water filter	Std		Filter to remove impurities from the water supply.
Remote On/Off control	Accessory		It enables the operator to power on the unit when it is in standby mode, to display alarms and switch over cooling-heat pump. Maximum length: 50mt.
Remote keyboard panel	Accessory		Makes it possible to control the unit through the remote terminal, up to a maximum distance of 400mt of telephone cable.
Flow switch	Accessory	FS	Prevents the operation of the unit if the circulating chilled fluid is insufficient. It is recommended to install a flow switch to ensure the correct operation of the unit.
Water pressure switch	Accessory		Mechanical water pressure switch to be mounted on the field installation on installation water piping to prevent very low Water Pressure.
Valve in out	Accessory		Ball valves makes it possible to insulate unit hydraulic circuit from the rest of the installation.
Inverter driven pump	Option	1PSP	Pump is equipped with an additional frequency converter 0-10 V driven by the main board, managing pump speed according - Capacity request (DT control) - Fixed speed (Manual flow control).
Domestic hot water management	Accessory		Controller manages DHW production with dedicated Set-Point and field components. Check the operating limits in the dedicated section.
Auxiliary heating source management	Accessory		Controller enables an auxiliary source of heating through a dedicated kit.
Set-Point secondary zone management	Accessory		Controller enables the management of a secondary zone with its own Set-Point.
Chassis Acoustic Insulation	Option	CAI	Internal acoustic insulation of the chassis to reduce noise emissions.

Accessories are loosed and to install in the field. Options are mounted in factory.

Refrigerant Flow Diagram

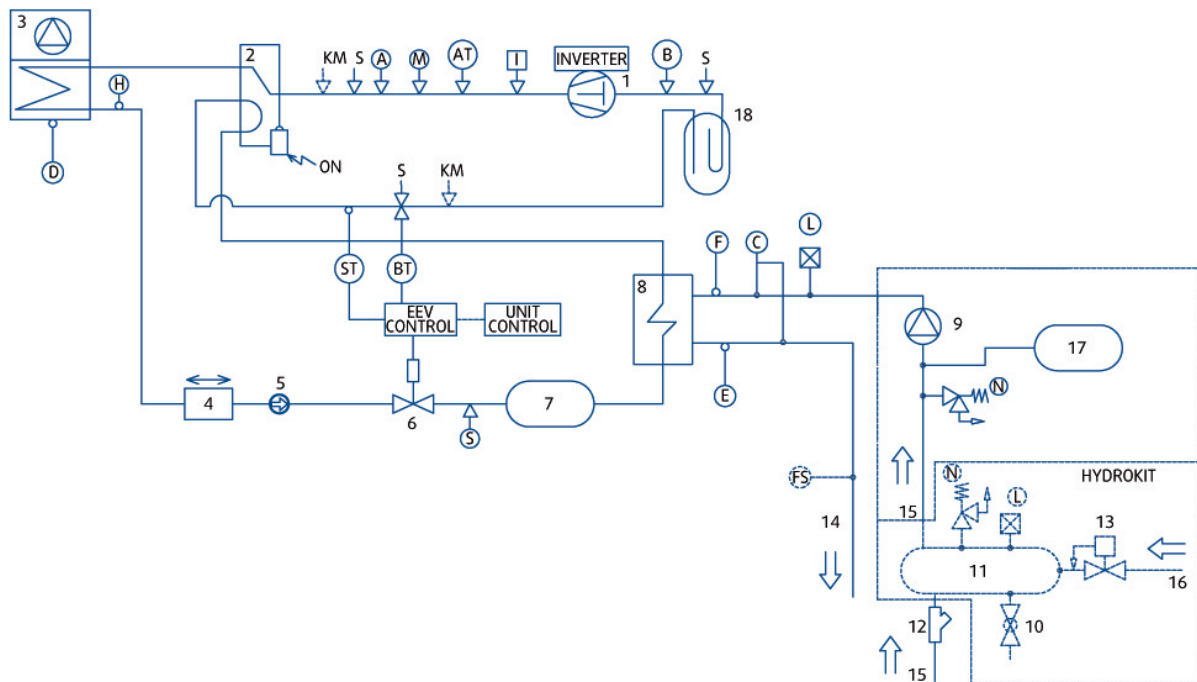

COMPONENTS

- 1 Inverter driven Scroll compressor
- 2 4-way valve
- 3 Air cooled condenser
- 4 Biflow filter drier
- 5 Sight glass
- 6 Expansion valve
- 7 Liquid receiver
- 8 Plate heat exchanger
- 9 Inverter driven pump (optional)
- 10 Drain valve
- 11 Water buffer tank
- 12 Water filter (loose)
- 13 Automatic water charging valve
- 14 Water outlet
- 15 Water inlet
- 16 Water charging line
- 17 Expansion vessel (lt 5)
- 18 Suction accumulator

SAFETY/CONTROL DEVICES

- A High pressure switch (40,5 bar)
- AT High pressure transducer
- B Low pressure switch (1,5 bar)
- BT Low pressure transducer
- C Water differential pressure switch (105 mbar)
- D Air temperature sensor
- E Outlet water temperature sensor
- F Inlet water temperature sensor
- FS Flow switch
- H Defrost temperature sensor
- I Discharge gas temperature thermostat-DGT
- L Vent valve
- M Discharge temperature sensor
- N Water safety valve (3 bar)
- S Shrader valve (Service/Charging point)
- ST Suction temperature probe
- ↓ Pipe connection with Shrader valve 1/4" SAE
- Optional components
- Probes

Operating Limits - SYSCROLL 20 AIR EVO HP

Cooling operation / Max capacity

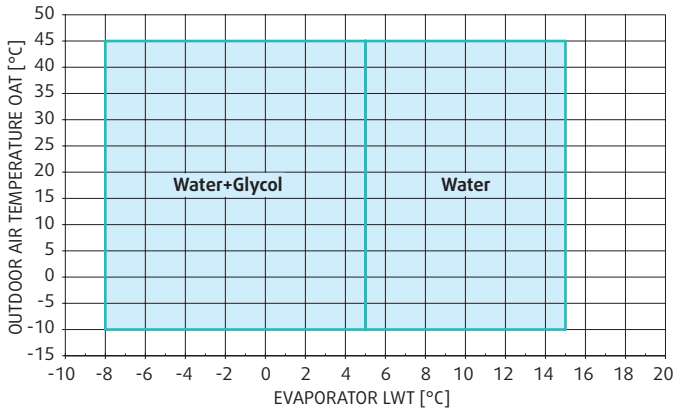

Cooling operation / Nominal capacity

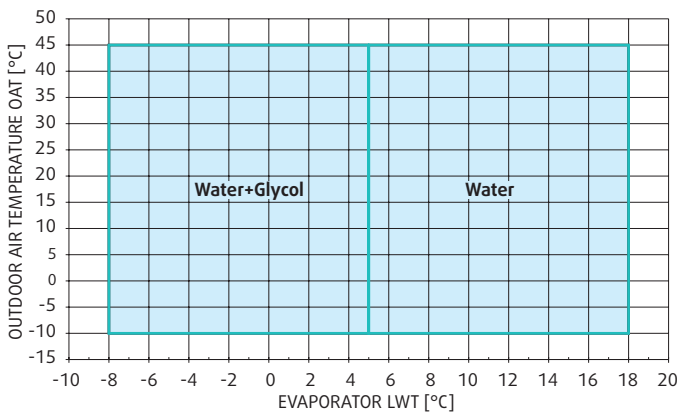

Heating operation / Max capacity

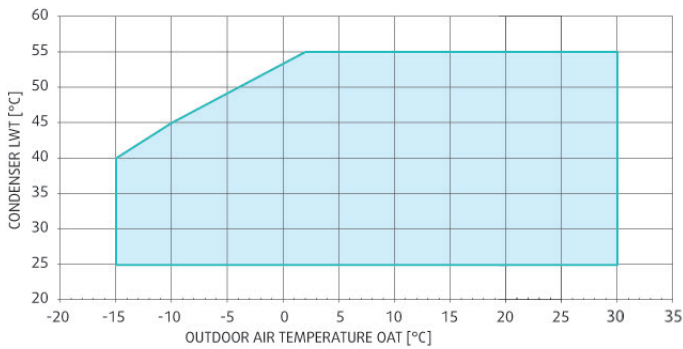

Heating operation / Nominal capacity

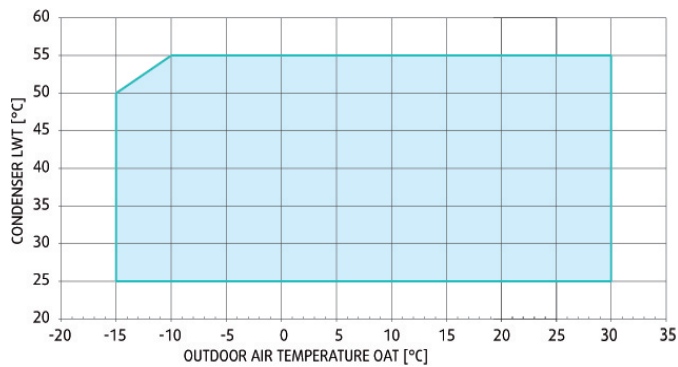

Operating Limits - SYSCROLL 30 AIR EVO HP

Cooling operation / Max capacity

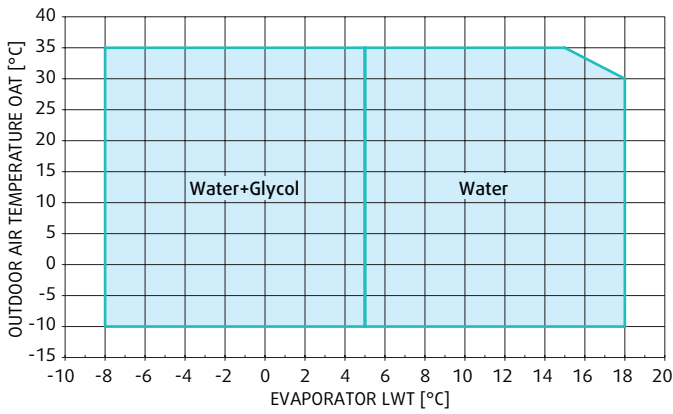

Cooling operation / Nominal capacity

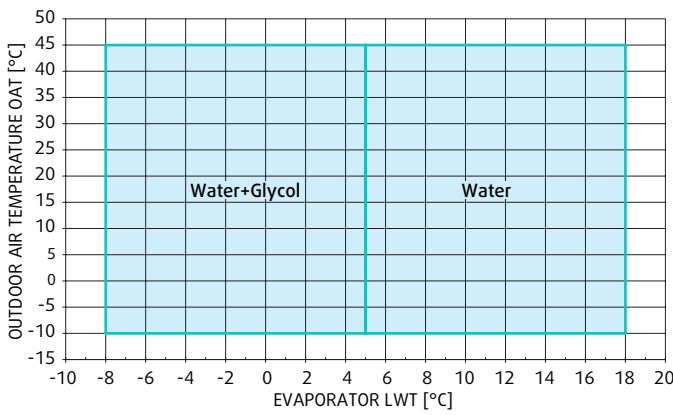

Heating operation / Max capacity

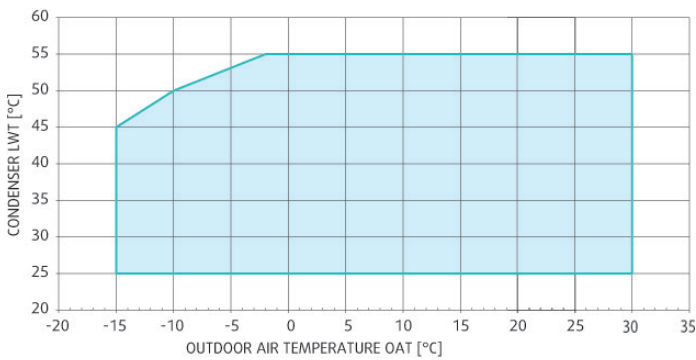

Heating operation / Nominal capacity

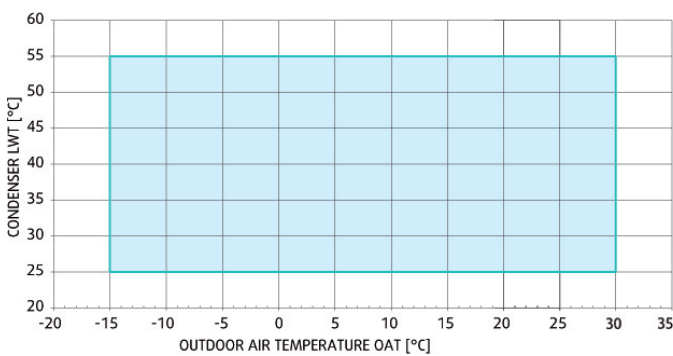

Performances corrective factors (brine)

Unit capacity, absorbed power, brine flow rate, brine pressure drop, have to be corrected according following formula:

CORRECTED UNIT CAPACITY

$$Q_{\text{CORRECTED/GLYCOL}} = Q_{\text{NOMINAL}} \times K_c \times K_c^{E,P}$$

Where K_c : Capacity corrective factor according to LWT ($\Delta T = 5$ [K]) → refer to [Table 1](#)

K_c^E : Capacity corrective factor according to glycol percentage (ETHYLENE GLYCOL) → refer to [Table 2](#)

K_c^P : Capacity corrective factor according to glycol percentage (PROPYLENE GLYCOL) → refer to [Table 4](#)

CORRECTED UNIT ABSORBED POWER

$$P_{\text{CORRECTED/GLYCOL}} = P_{\text{NOMINAL}} \times K_i \times K_i^{E,P}$$

Where K_i : Absorbed power corrective factor according to LWT ($\Delta T = 5$ [K]) → refer to [Table 1](#)

K_i^E : Absorbed power corrective factor according to glycol percentage (ETHYLENE GLYCOL) → refer to [Table 2](#)

K_i^P : Absorbed power corrective factor according to glycol percentage (PROPYLENE GLYCOL) → refer to [Table 4](#)

CORRECTED BRINE FLOW RATE

$$G_{\text{CORRECTED/GLYCOL}} = G_{\text{RE-CALCULATED}} \times K_f^{E,P}$$

Where $G_{\text{RE-CALCULATED}}$: Flow rate according to $P_{\text{CORRECTED/GLYCOL}}$ ($P_{\text{CORRECTED/GLYCOL}} \times 860 / \Delta T / 3600$)

K_f^E : Flow rate corrective factor according to glycol percentage (ETHYLENE GLYCOL) → refer to [Table 2](#)

K_f^P : Flow rate corrective factor according to glycol percentage (PROPYLENE GLYCOL) → refer to [Table 4](#)

CORRECTED BRINE PRESSURE DROP

$$\Delta P_{\text{CORRECTED/GLYCOL}} = \Delta P_{\text{PRE-CALCULATED}} \times K_p^{E,P}$$

Where $\Delta P_{\text{RE-CALCULATED}}$: Pressure drop according to $G_{\text{CORRECTED/GLYCOL}}$ ($K_{\text{BPHE}} \times (G_{\text{CORRECTED/GLYCOL}})^2$)

K_p^E : Pressure drop corrective factor according to glycol percentage (ETHYLENE GLYCOL) → refer to [Table 2](#)

K_p^P : Pressure drop corrective factor according to glycol percentage (PROPYLENE GLYCOL) → refer to [Table 5](#)

Table 1

		K_c	K_i
Leaving water temperature [LWT] (°C) ($\Delta T=5$ [K])	7	1,000	1,000
	4	0,887	0,940
	2	0,816	0,900
	0	0,748	0,865
	-2	0,685	0,826
	-4	0,624	0,788
	-6	0,568	0,753
	-8	0,513	0,718
	-10	0,461	0,683

Table 2

Ethylene Glycol Percentage		0%	10%	20%	30%	35%	40%
Freezing point (*)	°C	0	-4	-10	-10	-21	-21
Minimum leaving water temperature allowed	°C	6	2	-2	-2	-8	-8
Capacity corrective factor (**)	K_c^E	1	0,995	0,985	0,985	0,963	0,963
Absorbed power corrective factor (**)	K_i^E	1	0,998	0,995	0,995	0,983	0,983
Flow rate corrective factor	K_f^E	1	1,015	1,050	1,050	1,123	1,123
Pressure drop corrective factor (***)	K_p^E	1	1,070	1,160	1,160	1,283	1,283

(*) ASHRAE Handbook Fundamentals.

(**) Valid for LWT=7 [°C]. If LWT<7 [°C] consider $K_c \times K_c^E$ and $K_i \times K_i^E$

(***) Valid for LWT > 5 [°C]. If LWT<5°C → refer to [Table 3](#)

Table 3

Ethylene Glycol Percentage	LWT [°C]	Corrective factor K_f^E	Corrective factor K_p^E
10%	5	1,0154	1,0710
	4	1,0154	1,0760
	3	1,0154	1,0810
	2	1,0154	1,0850
20%	1	1,0417	1,1930
	0	1,0423	1,2000
	-1	1,0428	1,2080
	-2	1,0434	1,2150
30%	-3	1,0927	1,2990
	-4	1,0936	1,3060
	-5	1,0945	1,3200
	-6	1,0954	1,3330

Table 4

Propylene Glycol Percentage		0%	10%	20%	30%	40%
Freezing point (*)	°C	0	-3	-7	-13	-22
Capacity corrective factor (**)	K_c^P	1	0,991	0,977	0,945	0,911
Absorbed power corrective factor (**)	K_i^P	1	0,994	0,991	0,975	0,966
Flow rate corrective factor	K_f^P	1	1,005	1,030	1,067	1,130

(*) ASHRAE Handbook Fundamentals.

(**) Valid for LWT=7 [°C]. If LWT<7 [°C] consider $K_c \times K_c^P$ and $K_i \times K_i^P$

Table 5

Ethylene Glycol Percentage	LWT [°C]	Corrective factor $K_{p,p}$
10%	5	1,112
	4	1,134
20%	5	1,175
	4	1,196
	3	1,206
30%	5	1,290
	4	1,300
	3	1,310
	0	1,362
	-2	1,393
40%	-4	1,414
	5	1,433
	4	1,435
	3	1,456
	0	1,497
	-2	1,549
	-4	1,580
-6	1,612	
-8	1,653	

Technical data

Model		20			30		
Heating capacity - (min / nom / max) (1)	kW	9,94	20,4	29,4	11,5	26,1	34,0
Power input (1)	kW	2,98	5,02	8,37	3,01	6,45	9,80
COP (1)	kW/kW	3,34	4,06	3,51	3,82	4,05	3,47
Capacity range (1)	%	49%	-	144%	44%	-	130%
Cooling Capacity - (min / nom / max) (2)	kW	9,33	20,0	28,0	13,9	29,0	35,9
Power input (2)	kW	2,38	4,15	6,61	3,51	7,24	13,0
EER (2)	kW/kW	3,92	4,82	4,24	3,96	4,01	2,76
EUROVENT CLASS (EER) (2)			A			A	
Capacity range (2)	%	47%	-	140%	48%	-	124%
Heating capacity - (min / nom / max) (3)	kW	8,90	20,4	27,4	10,2	26,1	33,5
Power input (3)	kW	3,34	6,44	9,64	3,97	8,42	11,6
COP (3)	kW/kW	2,66	3,17	2,84	2,57	3,10	2,89
Capacity range (3)	%	44%	-	134%	39%	-	128%
Cooling Capacity - (min / nom / max) (4)	kW	6,60	21,0	25,2	9,43	28,0	31,1
Power input (4)	kW	2,52	6,95	10,3	3,14	10,89	12,4
EER (4)	kW/kW	2,62	3,02	2,45	3,00	2,57	2,51
EUROVENT CLASS (EER) (4)			B			C	
Capacity range (4)	%	33%	-	126%	33%	-	107%
EER 75%	kW/kW		3,83			3,65	
EER 50%	kW/kW		4,53			4,48	
EER 25%	kW/kW		3,80			4,79	
SEER (5)			3,30			3,98	
η_{sc} (5)			129			156	
SCOP (6)			3,75			3,68	
EUROVENT CLASS (SCOP) (6)			A+			A+	
η_{sh} (6)			147			144	
SCOP (7)			3,00			2,95	
EUROVENT CLASS (SCOP) (7)			A+			A+	
η_{sh} (7)			117			115	
Number of Refrigerant Circuits						1	
Part Load Steps	%					Stepless	
Power Supply	V/ph/Hz					400/3+N/50	
Startup Type						Soft-start (inverter)	
Maximum Absorbed Power	kW		13,2			15,8	
Maximum Current (FLA)	A		25,9			30,9	
Startup Current (LRA)	A		3,9			3,9	
Refrigerant							
Type						R410A	
Compressor							
Number / Type						1 / Scroll (BLDC Motor)	
Crankcase Heater	W					40	
Internal heat exchanger							
Number						1	
Type						Brazed plate	
Water flow Rate / Water Pressure Drop	l/h / kPa					Refer to hydraulic circuit data	
Antifreeze Heater	W					35	
Fans							
Number			2			2	
Air Flow Rate	m ³ /h		10.848			10.425	
Input Power	kW		0,54			0,54	
Pump							
Number			1			1	
Input Power	kW		0,56			0,63	
Water flow Rate / Water Pressure Drop	l/h / kPa					Refer to hydraulic circuit data	
Water Connections							
Type						Male GAS Threaded	
Inlet Diameter / Outlet Diameter	inch					1" 1/4	

- (1) Eurovent LCP/A/CHF conditions in heating mode: water heat exchanger EWT/LWT → 30°C/35°C, OAT → 7°C db/6°C WB according EN14511 standard.
 (2) Eurovent LCP/A/CHF conditions in cooling mode: water heat exchanger EWT/LWT → 23°C/18°C, OAT → 35°C according EN14511 standard.
 (3) Eurovent LCP/A/AC conditions in heating mode: water heat exchanger EWT/LWT → 40°C/45°C, OAT → 7°C db/6°C WB according EN14511 standard.
 (4) Eurovent LCP/A/AC conditions in cooling mode: water heat exchanger EWT/LWT → 12°C/7°C, OAT → 35°C according EN14511 standard.
 (5) According to EN14825 standard and following COMMISSION REGULATION (EU) No 2016/2281 for comfort application chillers.
 (6) According to EN14825 standard - low temperature application (35°C) and following COMMISSION REGULATION (EU) No 813/2013 for heat pumps.
 (7) According to EN14825 standard - medium temperature application (55°C) and following COMMISSION REGULATION (EU) No 813/2013 for heat pumps.

Model		20	30
Weight			
Shipping	kg	266	281
Operating	kg	260	275
Dimensions			
Length	mm	1.477	1.477
Width	mm	539	539
Height	mm	1.615	1.615
Acoustic Data			
Sound Power Level	dB(A)	74	75
Sound Pressure Level(7)	dB(A)	43	44

(7) Sound Pressure calculated at 10m. Values refers to ISO Standard 3744 with parallepiped shape.

Electrical Data

SYSCROLL AIR EVO HP		20	30
Power supply	V/ph/Hz	400 ± (10%)/3+N/50	
Maximum power input	kW	13,2	15,8
Maximum current input	A	25,9	30,9
Start-up corrent	A	3,9	3,9
External fuses	A	32	32
Max cable section (*)	mm ²	10	10
Heat exchanger resistance			
Power supply	V/ph/Hz	230 ± (10%)/1/50	
Maximum power input	W	35	

(*) The dimensioning of the unit's power cables is the responsibility of the installer, who shall consider: the rating, the maximum working temperature in the room, the type of insulation and the cable laying, the maximum lenght of the power supply line.

Compressor data

SYSCROLL AIR EVO HP		20	30
Power supply	V/ph/Hz	400 ± (10%)/3/50	
Number		1	
Maximum power input	kW	11,9	14,4
Nominal current input	A	15,0	20,0
Maximum current input	A	22,0	27,0
Crankcase heater (230±(10%)/1/50)	W	40	

Fan data

SYSCROLL AIR EVO HP		20	30
Power supply	V/ph/Hz	230 ± (10%)/1/50	
Number		2	
Maximum power input	kW	0,3+0,3	
Nominal current input	A	1,3+1,3	

Pump data

SYSCROLL AIR EVO HP		20	30
Power supply	V/ph/Hz	400 ± (10%)/3/50	
Number		1	
Maximum power input	kW	0,72	
Nominal current input	A	1,3	

Sound Data

Size	Octave Band (Hz)								Sound Power Level dB(A)	Sound Pressure Level* dB(A)
	63	125	250	500	1000	2000	4000	8000		
	Sound Power Level (dB)									
20	84	68	71	70	70	65	59	54	74	42
30	86	69	72	71	70	66	59	56	75	43

* Sound pressure level at 10 m. Values refers to ISO Standard 3744 with parallepiped shape.

Nominal performances* (different speeds) - SYSCROLL 20 AIR EVO HP

Cooling operation

SYSCROLL 20 AIR EVO HP		OAT (°C)														
		25			30			35			40			45		
		P _{COOL} (kW)	P _{ABS} (kW)	EER kW/kW	P _{COOL} (kW)	P _{ABS} (kW)	EER kW/kW	P _{COOL} (kW)	P _{ABS} (kW)	EER kW/kW	P _{COOL} (kW)	P _{ABS} (kW)	EER kW/kW	P _{COOL} (kW)	P _{ABS} (kW)	EER kW/kW
LWT (°C)	5	20,0	5,98	3,34	20,0	7,05	2,84	20,0	7,77	2,57	20,0	9,72	2,06	19,4	11,3	1,71
	7	20,0	5,08	3,94	20,0	5,82	3,44	20,0	6,65	3,01	20,0	8,56	2,34	20,0	10,6	1,89
	10	20,0	4,10	4,88	20,0	4,83	4,14	20,0	5,93	3,37	20,0	7,55	2,65	20,0	9,49	2,11
	15	20,0	3,60	5,56	20,0	4,08	4,90	20,0	4,72	4,24	20,0	5,96	3,36	20,0	7,49	2,67
	18	20,0	3,47	5,76	20,0	3,92	5,10	20,0	4,15	4,82	20,0	5,55	3,60	20,0	7,12	2,81

Heating operation

SYSCROLL 20 AIR EVO HP		OAT (°C)											
		-15			-10			-7			-2		
		P _{HEAT} (kW)	P _{ABS} (kW)	COP kW/kW	P _{HEAT} (kW)	P _{ABS} (kW)	COP kW/kW	P _{HEAT} (kW)	P _{ABS} (kW)	COP kW/kW	P _{HEAT} (kW)	P _{ABS} (kW)	COP kW/kW
LWT (°C)	35	12,8	7,67	1,67	16,5	7,82	2,11	19,7	7,95	2,48	20,5	7,59	2,69
	40	13,6	8,36	1,62	16,9	8,50	1,99	19,5	8,61	2,26	20,4	8,61	2,37
	45	12,3	8,21	1,50	17,3	9,18	1,88	19,3	9,26	2,08	20,4	8,98	2,28
	50	9,82	7,42	1,32	14,0	7,97	1,75	16,1	9,44	1,71	20,4	9,87	2,07
	55				10,3	7,28	1,42	12,8	8,32	1,54	18,8	9,47	1,98

SYSCROLL 20 AIR EVO HP		OAT (°C)								
		2			7			12		
		P _{HEAT} (kW)	P _{ABS} (kW)	COP kW/kW	P _{HEAT} (kW)	P _{ABS} (kW)	COP kW/kW	P _{HEAT} (kW)	P _{ABS} (kW)	COP kW/kW
LWT (°C)	35	20,4	6,68	3,06	20,4	5,02	4,06	20,4	4,40	4,65
	40	20,4	7,35	2,78	20,4	6,09	3,36	20,4	4,97	4,11
	45	20,4	8,01	2,55	20,4	6,44	3,17	20,4	5,58	3,66
	50	20,4	8,46	2,42	20,4	7,14	2,86	20,4	6,23	3,28
	55	20,4	8,85	2,31	20,4	8,41	2,43	20,4	6,93	2,95

(*) Data according EN 14511 standard.

Max performances* (different speeds) - SYSCROLL 20 AIR EVO HP

Cooling operation

SYSCROLL 20 AIR EVO HP		OAT (°C)														
		25			30			35			40			45		
		P _{COOL} (kW)	P _{ABS} (kW)	EER kW/kW	P _{COOL} (kW)	P _{ABS} (kW)	EER kW/kW	P _{COOL} (kW)	P _{ABS} (kW)	EER kW/kW	P _{COOL} (kW)	P _{ABS} (kW)	EER kW/kW	P _{COOL} (kW)	P _{ABS} (kW)	EER kW/kW
LWT (°C)	5	25,6	8,82	2,90	24,4	9,48	2,57	23,4	10,2	2,30	21,3	10,7	1,98	19,4	11,3	1,71
	7	28,6	8,95	3,20	26,8	9,6	2,79	25,2	10,3	2,46	23,0	10,9	2,11	20,9	11,6	1,81
	10	33,1	9,13	3,63	30,5	9,8	3,12	27,9	10,4	2,69	25,6	11,2	2,30	23,3	11,9	1,96
	15	40,6	9,44	4,30	36,7	10,1	3,64	32,3	10,6	3,04	30,0	11,6	2,60	27,1	12,4	2,19
	18	31,5	5,93	5,31	29,4	6,51	4,52	28,0	6,61	4,24	25,6	7,86	3,26	22,9	8,62	2,66

Heating operation

SYSCROLL 20 AIR EVO HP		OAT (°C)											
		-15			-10			-7			-2		
		P _{HEAT} (kW)	P _{ABS} (kW)	COP kW/kW	P _{HEAT} (kW)	P _{ABS} (kW)	COP kW/kW	P _{HEAT} (kW)	P _{ABS} (kW)	COP kW/kW	P _{HEAT} (kW)	P _{ABS} (kW)	COP kW/kW
LWT (°C)	35	12,8	7,67	1,67	16,5	7,82	2,11	19,7	7,95	2,48	22,4	8,05	2,79
	40	13,6	8,36	1,62	16,9	8,50	1,99	19,5	8,61	2,26	22,3	8,72	2,55
	45	12,3	8,21	1,50	17,3	9,18	1,88	19,3	9,26	2,08	22,1	9,39	2,36
	50	9,82	7,42	1,32	14,0	7,97	1,75	16,1	9,44	1,71	22,0	10,1	2,18
	55				10,3	7,28	1,42	12,8	8,32	1,54	18,8	9,47	1,98

SYSCROLL 20 AIR EVO HP		OAT (°C)								
		2			7			12		
		P _{HEAT} (kW)	P _{ABS} (kW)	COP kW/kW	P _{HEAT} (kW)	P _{ABS} (kW)	COP kW/kW	P _{HEAT} (kW)	P _{ABS} (kW)	COP kW/kW
LWT (°C)	35	23,4	8,05	2,90	29,4	8,37	3,52	33,4	8,48	3,94
	40	23,8	8,76	2,72	28,5	9,01	3,16	32,1	9,11	3,52
	45	24,2	9,47	2,56	27,4	9,64	2,84	30,7	9,74	3,16
	50	24,6	10,2	2,42	26,5	10,3	2,58	29,4	10,4	2,84
	55	25,1	10,9	2,30	25,5	10,9	2,34	28,1	11,0	2,55

(*) Data according EN 14511 standard.

Nominal performances* (different speeds) - SYSCROLL 30 AIR EVO HP

Cooling operation

SYSCROLL 30 AIR EVO HP		OAT (°C)														
		25			30			35			40			45		
		P _{COOL} (kW)	P _{ABS} (kW)	EER kW/kW	P _{COOL} (kW)	P _{ABS} (kW)	EER kW/kW	P _{COOL} (kW)	P _{ABS} (kW)	EER kW/kW	P _{COOL} (kW)	P _{ABS} (kW)	EER kW/kW	P _{COOL} (kW)	P _{ABS} (kW)	EER kW/kW
LWT (°C)	5	29,0	7,84	3,70	29,0	9,38	3,09	29,0	10,8	2,69	27,1	12,9	2,11	23,0	11,5	2,01
	7	29,0	7,28	3,98	29,0	9,31	3,11	29,0	10,7	2,71	29,0	12,7	2,28	24,0	12,2	1,97
	10	29,0	7,13	4,07	29,0	7,69	3,77	29,0	10,1	2,88	28,9	12,1	2,39	24,8	11,2	2,22
	15	29,0	5,91	4,91	29,0	6,84	4,24	29,0	7,72	3,76	29,0	10,1	2,88	25,5	9,88	2,58
	18	29,0	5,32	5,45	29,0	6,31	4,60	29,0	7,24	4,01	29,0	9,61	3,02	25,9	9,64	2,69

Heating operation

SYSCROLL 30 AIR EVO HP		OAT (°C)											
		-15			-10			-7			-2		
		P _{HEAT} (kW)	P _{ABS} (kW)	COP kW/kW	P _{HEAT} (kW)	P _{ABS} (kW)	COP kW/kW	P _{HEAT} (kW)	P _{ABS} (kW)	COP kW/kW	P _{HEAT} (kW)	P _{ABS} (kW)	COP kW/kW
LWT (°C)	35	17,7	8,53	2,07	21,5	8,82	2,43	24,5	9,03	2,71	26,1	8,59	3,04
	40	17,8	9,20	1,94	21,5	9,52	2,25	24,0	9,72	2,47	26,1	9,57	2,73
	45	18,0	9,87	1,82	21,5	10,2	2,10	23,6	10,4	2,27	26,1	10,6	2,47
	50	15,3	10,0	1,53	21,5	10,9	1,96	23,1	11,1	2,08	26,1	10,9	2,40
	55	10,5	8,89	1,18	14,4	9,06	1,58	20,1	10,3	1,96	26,1	11,8	2,20

SYSCROLL 30 AIR EVO HP		OAT (°C)								
		2			7			12		
		P _{HEAT} (kW)	P _{ABS} (kW)	COP kW/kW	P _{HEAT} (kW)	P _{ABS} (kW)	COP kW/kW	P _{HEAT} (kW)	P _{ABS} (kW)	COP kW/kW
LWT (°C)	35	26,1	7,80	3,35	26,1	6,45	4,05	26,1	5,51	4,74
	40	26,1	8,59	3,04	26,1	7,46	3,50	26,1	6,20	4,21
	45	26,1	9,32	2,80	26,1	8,42	3,10	26,1	6,94	3,76
	50	26,1	10,0	2,61	26,1	9,02	2,89	26,1	7,50	3,48
	55	26,1	11,8	2,21	26,1	9,85	2,65	26,1	7,68	3,40

(*) Data according EN 14511 standard.

Max performances* (different speeds) - SYSCROLL 30 AIR EVO HP

Cooling operation

SYSCROLL 30 AIR EVO HP		OAT (°C)														
		25			30			35			40			45		
		P _{COOL} (kW)	P _{ABS} (kW)	EER kW/kW	P _{COOL} (kW)	P _{ABS} (kW)	EER kW/kW	P _{COOL} (kW)	P _{ABS} (kW)	EER kW/kW	P _{COOL} (kW)	P _{ABS} (kW)	EER kW/kW	P _{COOL} (kW)	P _{ABS} (kW)	EER kW/kW
LWT (°C)	5	33,6	10,4	3,22	31,9	11,2	2,84	30,3	12,1	2,51	27,1	12,9	2,11	23,0	11,5	2,01
	7	35,2	10,8	3,25	33,6	11,5	2,91	31,1	12,4	2,51	29,0	12,7	2,28	24,0	12,2	1,97
	10	36,8	11,0	3,34	35,6	11,9	3,00	33,5	12,8	2,62	28,9	12,1	2,39	24,8	11,2	2,22
	15	40,1	11,6	3,45	37,9	12,6	3,01	36,2	13,6	2,67	30,5	11,2	2,72	25,5	9,88	2,58
	18	42,5	12,1	3,52	39,8	13,0	3,05	35,9	13,0	2,76	31,1	11,3	2,75	25,9	9,64	2,69

Heating operation

SYSCROLL 30 AIR EVO HP		OAT (°C)											
		-15			-10			-7			-2		
		P _{HEAT} (kW)	P _{ABS} (kW)	COP kW/kW	P _{HEAT} (kW)	P _{ABS} (kW)	COP kW/kW	P _{HEAT} (kW)	P _{ABS} (kW)	COP kW/kW	P _{HEAT} (kW)	P _{ABS} (kW)	COP kW/kW
LWT (°C)	35	17,7	8,53	2,07	21,5	8,82	2,43	24,5	9,03	2,71	27,5	9,27	2,97
	40	17,8	9,20	1,94	21,5	9,52	2,25	24,0	9,72	2,47	27,3	10,0	2,72
	45	18,0	9,87	1,82	21,5	10,2	2,10	23,6	10,4	2,27	27,0	10,8	2,50
	50	15,3	10,0	1,53	21,5	10,9	1,96	23,1	11,1	2,08	26,8	11,6	2,31
	55	10,5	8,89	1,18	14,4	9,06	1,58	20,1	10,3	1,96	26,5	12,3	2,15

SYSCROLL 30 AIR EVO HP		OAT (°C)								
		2			7			12		
		P _{HEAT} (kW)	P _{ABS} (kW)	COP kW/kW	P _{HEAT} (kW)	P _{ABS} (kW)	COP kW/kW	P _{HEAT} (kW)	P _{ABS} (kW)	COP kW/kW
LWT (°C)	35	29,3	9,40	3,12	34,0	9,80	3,47	39,0	10,1	3,86
	40	29,5	10,3	2,87	33,8	10,7	3,16	37,8	10,9	3,47
	45	29,6	11,1	2,67	33,5	11,6	2,89	36,6	11,7	3,13
	50	29,8	12,0	2,49	33,2	12,5	2,66	35,5	12,5	2,84
	55	30,0	12,8	2,34	33,0	13,4	2,46	34,3	13,3	2,58

(*) Data according EN 14511 standard.

Variable flow hydronic systems

Two options of variable water flow:

- Manual flow adjustment
- Constant delta T

CONSTANT SPEED PUMP – VARIABLE FREQUENCY DRIVE ADJUSTMENT

The unit is equipped with a hydraulic kit driven by a variable frequency drive, without providing continuous modulation of the speed. The water flow is fixed during commissioning. The goal of this alternative is to provide the appropriate flow rate and hydraulic balance, without the need for a mechanical balancing valve, and by taking advantage of the energy consumption optimization of the pump. Water-flow is adjusted through the display.

VARIABLE SPEED PUMP – CONSTANT DIFFERENTIAL TEMPERATURE (DT)

The unit is equipped with a hydraulic kit driven by a variable frequency drive. The modulation of the pump speed is managed to ensure that the DT stays constant. Entering and leaving temperatures at the customer water loop will be measured directly by the controller, through the on board temperature probes. A DT setpoint will be present on the unit controller. The option for constant DT is intended to be used with 3-way valves on water systems, or 2-way valves on water system but constant flow at the by-pass. The minimum pump frequency can be adjusted on the inverter.

Pump Available Static Pressure

SYSCROLL 20 AIR EVO HP

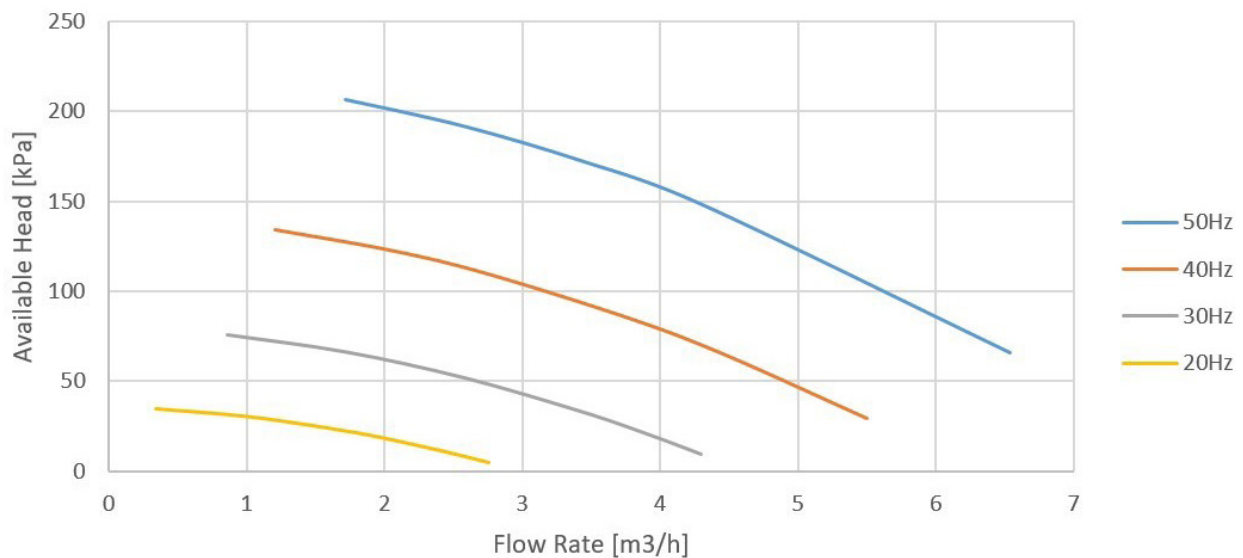

SYSCROLL 30 AIR EVO HP

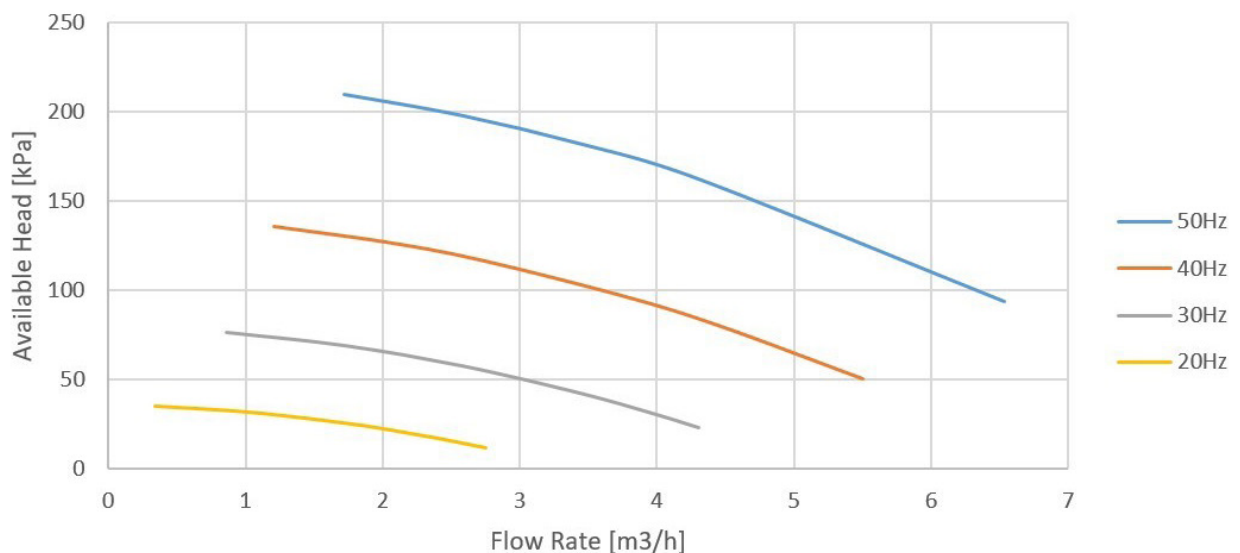

Pump Absorbed power

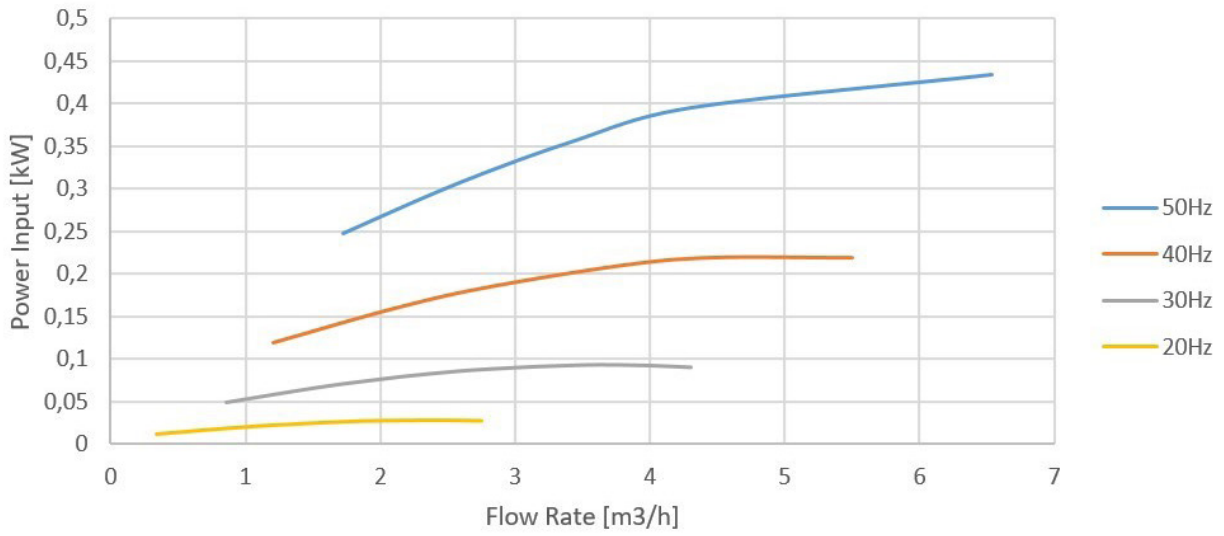

Water Circuit Pressure Drop

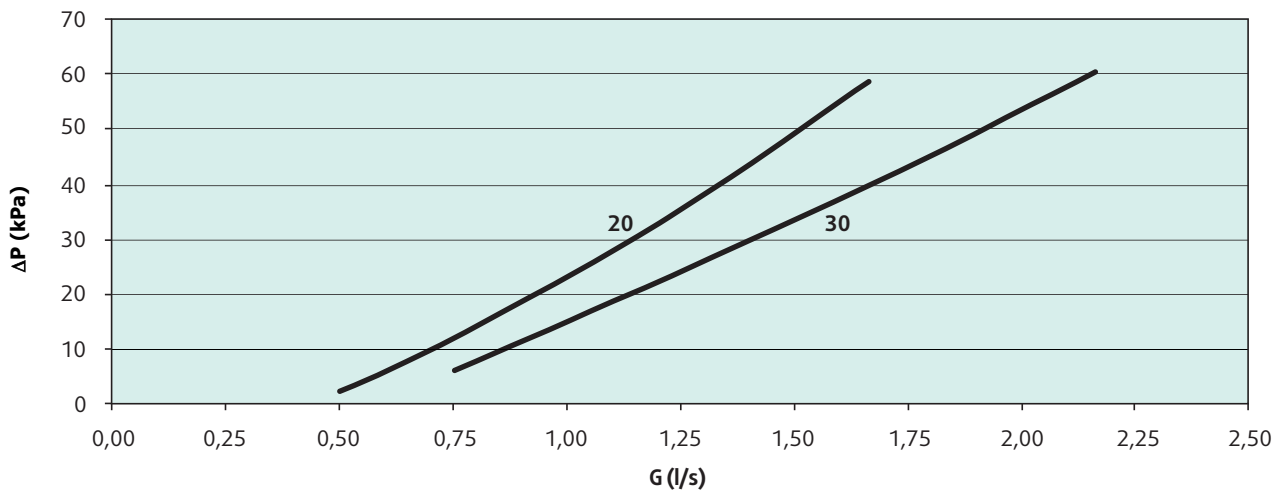

Water Filter* Pressure Drop

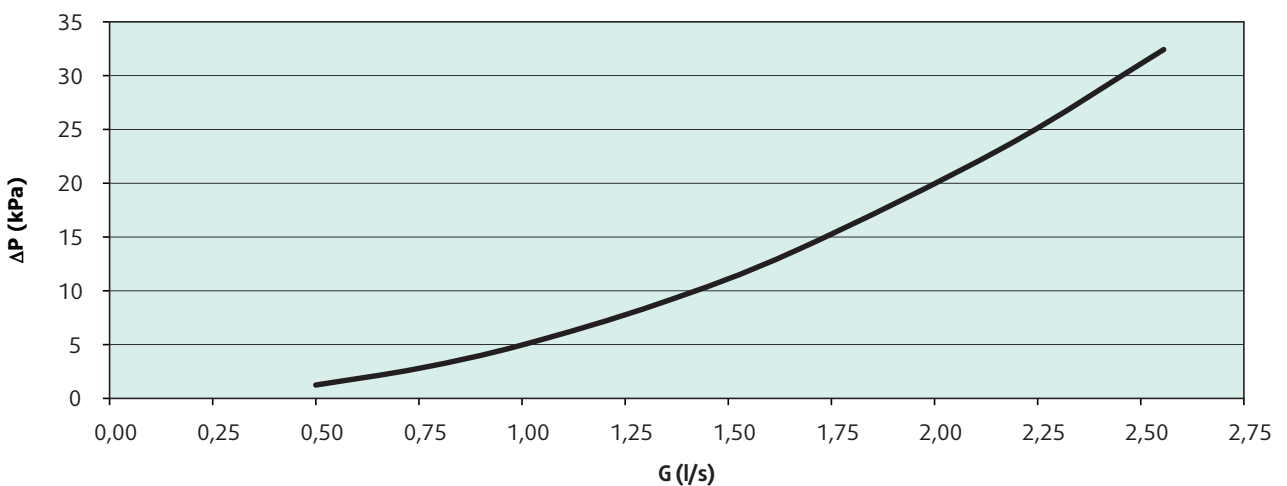

* 1"1/4 diameter, filtration capacity 500 μm / 35 mesh.

Dimensions SYSCROLL 20-30 AIR EVO

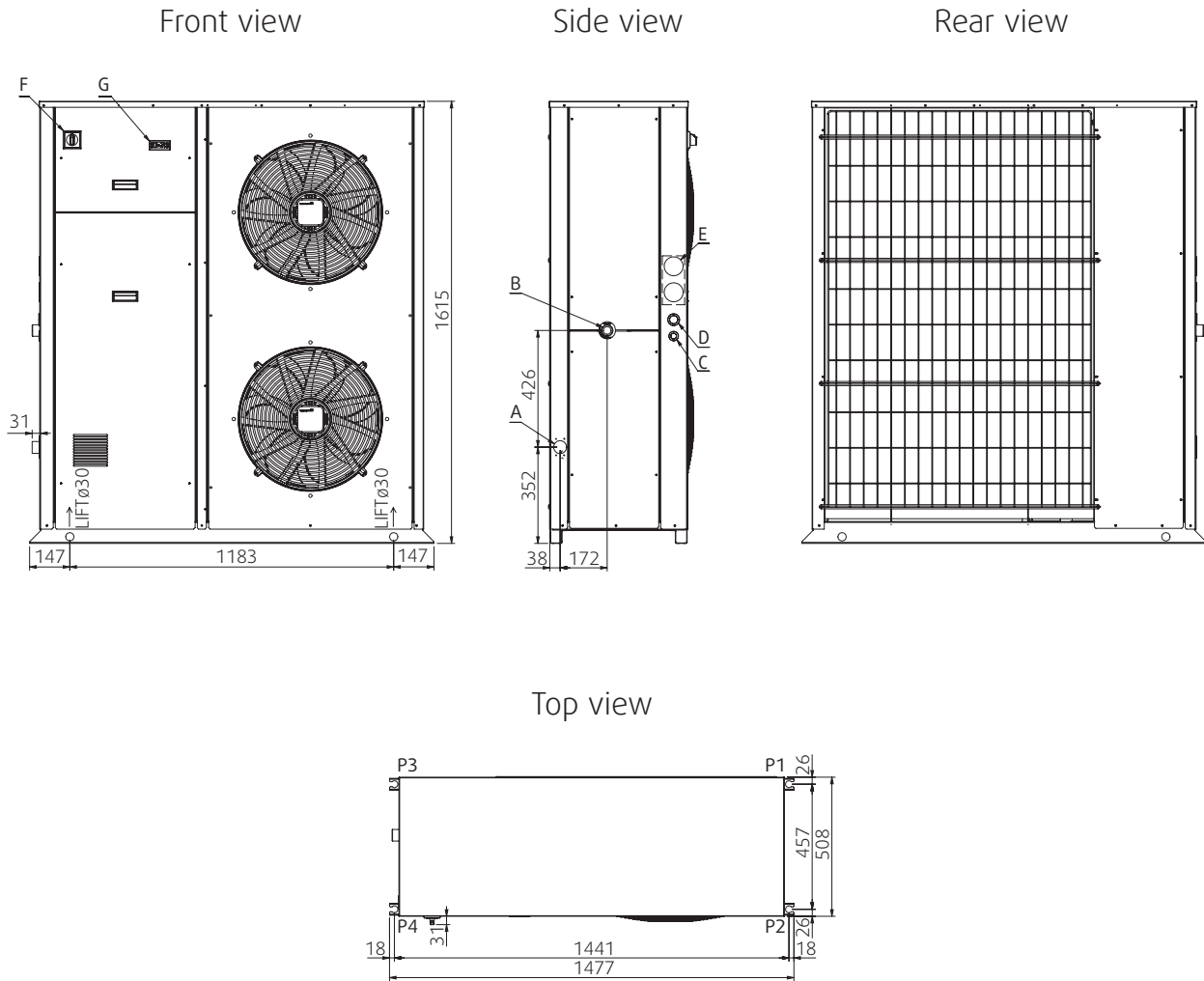

NOTES

- A Water inlet \varnothing 1 1/4" MGT
- B Water outlet \varnothing 1 1/4" MGT
- C Auxiliary lines
- D Electrical power supply
- E Gauge kit (optional)
- F Main switch
- G Control keypad/display

Dimensions Hydrokit 20-30 AIR EVO

Front view

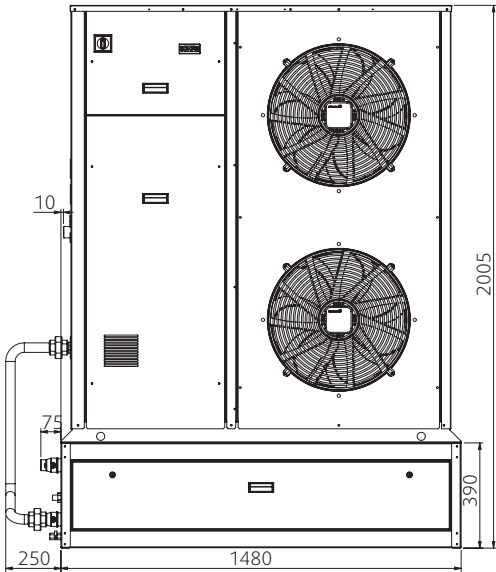

Side view

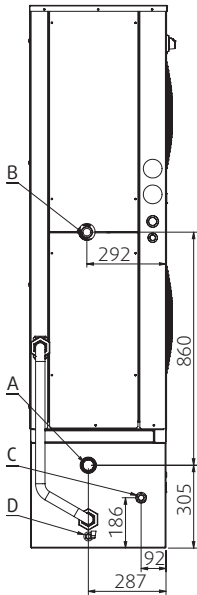

Rear view

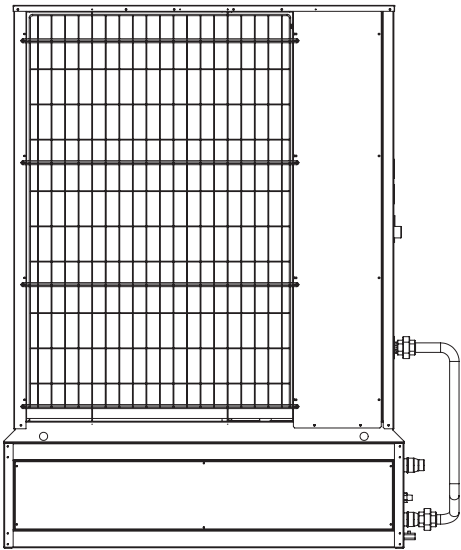

Top view

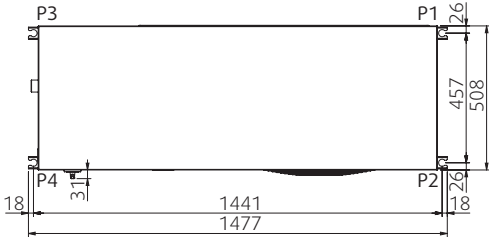

NOTES

- A Water inlet \varnothing 1 1/4" MGT
- B Water outlet \varnothing 1 1/4" MGT
- C Tank fill \varnothing 1 1/2" MGT
- D Water drain \varnothing 3/8" MGT

Space requirements

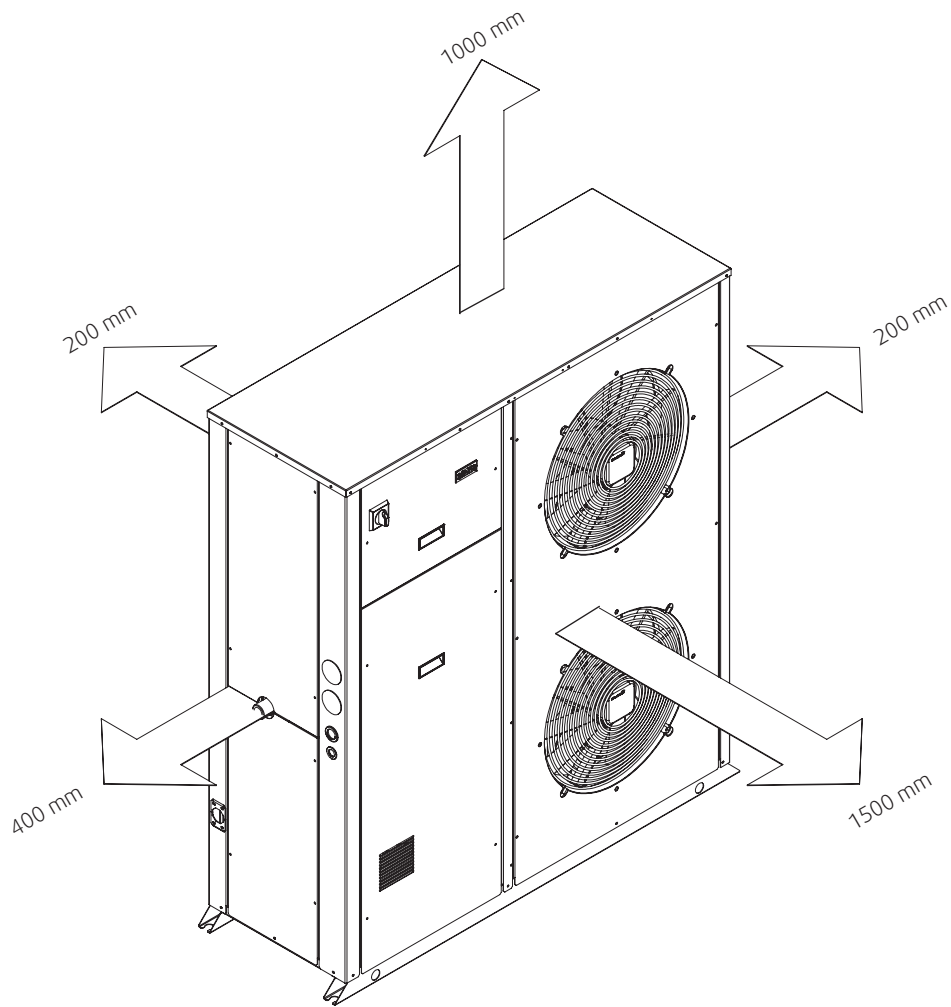

Systemair srl
Via XXV Aprile, 29
20825 Barlassina (MB)
Italy

Tel. +39 0362 680 1
Fax +39 0362 680 693

info@systemair.it

Systemair - January 2022 - EDM SYSCROLL 20-30 AIR EVO-S-8GB/01.22
As part of our ongoing product improvement programme, our products are subject to change without prior notice. Non contractual photos.