

Original Language

ECOi-W WQ 20-190 C/H/R

Water Cooled Liquid Chillers
Water to Water Reversible Heat Pumps
Condenserless Units

Cooling Only (C) and Reversible Heat Pump (H) units use R410A refrigerant.



ISO 9001:2015 certified management system

IMM_ECOi-W WQ 20-190 C/H/R-P-EN

September 2023

Part number : J39013



Read through the Installation Instructions before you proceed with the installation.

English

Français

Deutsch

Italiano

Español



Table of Contents

1 - FOREWORD		8 - TECHNICAL DATA		
1.1	Introduction and intended use.....	4	8.1 Pressure drops.....	41
1.2	Warranty.....	4	8.2 Technical data.....	42
1.3	Emergency stop / Normal stop.....	4	8.3 Refrigerant circuit specifications.....	48
1.4	An introduction to the manual.....	4	8.4 Unit electrical data.....	49
2 - SAFETY		9 - MAINTENANCE		
2.1	Foreword.....	5	9.1 General requirements.....	67
2.2	Definitions.....	6	9.2 Planned maintenance.....	67
2.3	Access to the unit.....	6	9.3 Refrigerant charge.....	68
2.4	General precautions.....	6	9.4 Compressor.....	68
2.5	Precautions against residual risks.....	6	9.5 Condenser.....	68
2.6	Precautions during maintenance operations.....	7	9.6 Dehydrating filter.....	68
2.7	Safety labels.....	8	9.7 Sight glass.....	68
2.8	Safety regulations.....	11	9.8 Mechanical expansion valve.....	69
3 - TRANSPORT, LIFTING AND POSITIONING		10 - TROUBLESHOOTING		
3.1	Inspection.....	14	11 - SPARE PARTS	
3.2	Handling.....	14	11.1 Spare part list.....	71
3.3	Anchoring.....	15	11.2 Oil for compressors.....	71
3.4	Storage.....	15	11.3 Wiring diagrams.....	71
4 - INSTALLATION		12 - DISASSEMBLY, RECYCLING AND/OR DISPOSAL AT END-OF-LIFE		
4.1	Positioning of the unit.....	16	12.1 Generalities.....	72
4.2	Spring Isolator Installation.....	16	12.2 WEEE Directive (only EU).....	72
4.3	Internal / external Water Circuit.....	17		
4.4	Water connections.....	24		
4.5	Power supply.....	24		
4.6	Electrical connections.....	25		
5 - START-UP				
5.1	Preliminary check.....	27		
5.2	Start-up.....	27		
5.3	Checking the operation.....	28		
5.4	Delivery to the customer.....	28		
6 - CONTROL				
6	General information.....	29		
6.1	Control of the units, single / double compressor.....	29		
6.2	Keypad functions.....	29		
6.3	Folder structure.....	30		
6.4	Menu structure.....	31		
6.5	Alarm list.....	34		
7 - GENERAL DESCRIPTION				
7.1	Introduction.....	35		
7.2	General Specifications.....	35		
7.3	Compressors.....	35		
7.4	Refrigeration circuits.....	35		
7.5	Evaporator.....	35		
7.6	Condenser (except for ECOi-W WQ R).....	35		
7.7	Switchboard.....	35		
7.8	Accessories.....	38		

1 - Foreword

1.1 Introduction and intended use

ECOi-W WQ are designed as cooling only systems (version «C», to cool water), as cooling / heating systems (version «H» for reversible heat pumps, to cool and heat water) or as remote condenser systems (version «R»).

The intended use for these units is for air-conditioning, and hot water production, and shall be intended for this use consistent with their performance. All uses not expressly stated in this manual are not permitted.

For all instructions concerning this product, please refer to this manual that is delivered with the unit. Units, manufactured to state-of-the-art design and implementation standards, ensure top performance, reliability and fitness to any type of air-conditioning systems.

These units are designed for cooling water or glycoled water (and for water heating in heat pump models) and are unfit for any purposes other than those specified in this manual.

This manual includes all the information required for a proper installation of the units, as well as the relevant operating and maintenance instructions.

It is therefore recommended to read this manual carefully before installation or any operation on the machine. The chiller installation and maintenance must be carried out by skilled personnel only (where possible, by an Authorised Service Centre).

The manufacturer may not be held liable for any damage to people or property caused by improper installation, start-up and/or improper use of the unit and/or failure to implement the procedures and instructions included in this manual.

1.2 Warranty

These units are delivered complete, tested and ready for being operated. Any form of warranty will become null and void in the event that the appliance is modified without manufacturer's preliminary written authorisation.

This warranty shall apply providing that the installation instructions have been complied with (either issued by manufacturer, or deriving from the current practice), and the Form 1 ("Start-up") has been filled-in and mailed to manufacturer (attn. After-Sales Service).

In order for this warranty to be valid, the following conditions shall be met:

- The machine must be operated only by skilled personnel from Authorised After-Sales or those that have been suitably trained.
- Maintenance must be performed only by skilled personnel - from an Authorised After-Sales Centre.
- Use only original spare parts.
- Carry out all the planned maintenance provided for by this manual in a timely and proper way.

Failure to comply with any of these conditions will automatically void the warranty.

1.3 Emergency stop / Normal stop

The emergency stop of the unit can be enabled using the master switch on the control panel (move down the lever).





For a normal stop, press the relevant push-buttons.

To restart the appliance, follow the procedure detailed in this manual.

1.4 An introduction to the manual

For safety reasons, it is imperative to follow the instructions given in this manual. In case of any damage caused by non-compliance with these instructions, the warranty will immediately become null and void.

Conventions used throughout the manual:

	The Danger sign recalls your attention to a certain procedure or practice which, if not followed, may result in serious damage to people and property.
	The Warning sign precedes those procedures that, if not followed, may result in serious damage to the appliance.
	The Notes contain important observations.
	The Useful Tips provide valuable information that optimises the efficiency of the appliance.

This manual and its contents, as well as the documentation which accompanies the unit, are and remain the property of manufacturer, which reserves any and all rights thereon. This manual may not be copied, in whole or in part, without manufacturer's written authorisation.

2 - Safety

2.1 Foreword

These units must be installed in conformity with the provisions of Machinery Directive 2006/42/EC, Pressure Equipment Directive 2014/68/EU, Electromagnetic Compatibility Directive 2014/30/EU, Low Voltage Directive 2014/35/EU as well as with other regulations applicable in the country of installation. If these provisions are not complied with, the unit must not be operated.

	<p>The unit must be grounded, and no installation and/or maintenance operations may be carried out before de-energising the electrical panel of the unit.</p>
---	--

Failure to respect the safety measures mentioned above may result in electrocution hazard and fire in the presence of any short-circuits.

	<p>Inside the heat exchangers, the compressors and the refrigeration lines, this unit contains liquid and gaseous refrigerant under pressure. The release of this refrigerant may be dangerous and cause injuries.</p>
---	---

	<p>The units are not designed to be operated with natural refrigerants, such as hydrocarbons. Manufacturer may not be held liable for any problems deriving from the replacement of original refrigerant or the introduction of hydrocarbons.</p>
--	--

Units are designed and manufactured according to the requirements of European Standard PED 2014/68/EU (pressure vessels).

- The used refrigerants are included in group II (non-hazardous fluids).
- The maximum working pressure values are mentioned on the unit's data plate.
- Suitable safety devices (pressure switches and safety valves) have been provided, to prevent any anomalous overpressure inside the plant.
- The vents of the safety valves are positioned and oriented in such a way as to reduce the risk of contact with the operator, in the event that the valve is operated. Please note, the installer will convey the discharge of the valves far from the unit.
- Dedicated guards (removable panels with tools) and danger signs indicate the presence of hot pipes or components (high surface temperature).

	<p>It is the User's responsibility to ensure that the unit is fit for the conditions of intended use and that both installation and maintenance are carried out by experienced personnel, capable of respecting all the recommendations provided by this manual.</p> <p>It is important that the unit is adequately supported, as detailed in this manual. Non-compliance with these recommendations may create hazardous situations for the personnel.</p>
---	---

	<p>The unit must rest on a base which meets the characteristics specified in this manual; a base with inadequate characteristics is likely to become a source of serious injury to the personnel.</p>
---	--

	<p>The unit has not been design to withstand loads and/or stress that may be transmitted by adjacent units, piping and/or structures.</p> <p>Each external load or stress transmitted to the unit may break or cause breakdowns in the unit's structure, as well as serious dangers to people. In these cases, any form of warranty will automatically become null and void.</p>
--	--

	<p>The packaging material must not be disposed of in the surrounding environment or burnt.</p>
---	---

2 - Safety (continued)

2.2 Definitions

OWNER: means the legal representative of the company, body or individual who owns the plant where unit has been installed; he / she has the responsibility of making sure that all the safety regulations specified in this manual are complied with, along with the national laws in force.

INSTALLER: means the legal representative of the company who has been given by the owner the job of positioning and performing the hydraulic, electric and other connections of unit to the plant: he / she is responsible for handling and properly installing the appliance, as specified in this manual and according to the national regulations in force.

OPERATOR: means a person authorised by the owner to perform the regulation and control operations expressly described in this manual for this unit, that must be strictly complied with, without exceeding the scope of the tasks entrusted to them.

ENGINEER: means a person authorised directly by manufacturer or, in all EC countries, excluding Italy, under his full responsibility, by the distributor of the product, to perform any routine and extraordinary maintenance operations, as well as any regulation, control, servicing operations and the replacement of components, as may be necessary during the life of the unit.

2.3 Access to the unit

The unit must be placed in an area which can be accessed also by OPERATORS and ENGINEERS; otherwise the unit must be surrounded by a fence not less than 2 meters from the external surface of the machine.

OPERATORS and ENGINEERS must enter the fenced area only when wearing suitable clothing (safety shoes, gloves, helmet etc.). The INSTALLER personnel or any other visitor must always be accompanied by an OPERATOR.

For no reason shall any unauthorised personnel be left alone in contact with the unit.

2.4 General precautions

The OPERATOR must simply use the controls of the unit; he must not open any panel, other than the one providing access to the control module.

The INSTALLER must simply work on the connections between plant and machine; he must not open any panels of the machine and he must not enable any control.

When you approach or work on the unit, follow the precautions listed below:

- do not wear loose clothing or jewellery or any other accessory that may be caught in moving parts
- wear suitable personal protective equipment (gloves, goggles etc.) when you have to work in the presence of free flames (welding operations) or with compressed air
- if the unit is placed in a closed room, wear ear protection devices

- cut off connecting pipes, drain them in order to balance the pressure to the atmospheric value before disconnecting them, disassemble connections, filters, joints or other line items
- do not use your hands to check for any pressure drops
- use tools in a good state of repair; be sure to have understood the instructions before using them
- be sure to have removed all tools, electrical cables and any other objects before closing and starting the unit again

2.5 Precautions against residual risks

Prevention of residual risks caused by the control system

- be sure to have perfectly understood the operating instructions before carrying out any operation on the control panel
- when you have to work on the control panel, always keep the operating instructions within reach
- start the unit only after you have checked its perfect connection to the plant
- promptly inform the ENGINEER about any alarm involving the unit
- do not reset manual restoration alarms unless you have identified and removed their cause

Prevention of residual mechanical risks

- install the unit according to the instructions provided in this manual
- carry out all the periodical maintenance operations prescribed by this manual
- wear a protective helmet before accessing the interior of the unit
- before opening any panelling of the machine, make sure that it is secured to it by hinges
- do not remove the guards from moving elements while the unit is running
- check the correct position of the moving elements' guards before restarting the unit

Prevention of residual electrical risks

- connect the unit to the mains according to the instructions provided in this manual
- periodically carry out all the maintenance operations specified by this manual
- disconnect the unit from the mains by the external disconnecting switch before opening the electrical board
- check the proper grounding of the unit before start-up
- check all the electrical connections, the connecting cables, and in particular the insulation; replace worn or damaged cables
- periodically check the board's internal wiring

2 - Safety (continued)

- do not use cables having an inadequate section or flying connections, even for limited periods of time or in an emergency

Prevention of other residual risks

- make sure that the connections to the unit conform to the instructions provided in this manual and on the unit's panelling
- if you have to disassemble a piece, make sure that it has been properly mounted again before restarting the unit
- do not touch the delivery pipes from the compressor, the compressor and any other piping or component inside the machine before wearing protective gloves
- keep a fire extinguisher for electrical appliances near the machine
- on the units installed indoor, connect the safety valve of the refrigeration circuit to a piping network that can channel any overflowing refrigerant outside
- remove any leak of fluid inside and outside the unit
- collect the waste liquids and dry any oil spillage
- periodically clean the compressor compartment, to remove any fouling
- do not store flammable liquids near the unit
- do not disperse the refrigerant and the lubricating oil into the environment
- braze only empty pipes; do not bring flames or other sources of heat to refrigerant pipes
- do not bend/hit pipes containing fluids under pressure

2.6 Precautions during maintenance operations

Maintenance operations can be carried out by authorised technicians only.

Before performing any maintenance operations:

- disconnect the unit from the mains with the external disconnecting switch

- isolate and lock off the mains supply and place a warning sign "do not turn on - maintenance in progress" on the external disconnecting switch
- make sure that on-off remote controls are inhibited
- wear suitable personal protective equipment (helmet, safety gloves, goggles and shoes etc.)

To carry out any measurements or checks which require the activation of the machine :

- work with the electrical board open only for a period necessary to complete measurements
- close the electrical board as soon as the measurement or check has been completed
- for outdoor units, do not carry out any operations in the presence of dangerous climatic conditions (rain, snow, mist etc.)
- The following precautions must be always adopted:
- do not release fluids of the refrigeration circuit in the surrounding environment
- when replacing an EPROM or electronic cards, always use suitable devices (extractor, antistatic bracelet, etc.)
- to replace a compressor, the evaporator, or any other weighty element, make sure that the lifting equipment is consistent with the weight to be lifted
- contact manufacturer for any modifications to the refrigeration, hydraulic or wiring diagram of the unit, as well as to its control logic
- contact manufacturer if it is necessary to perform very difficult disassembly and assembly operations
- use only original spare parts purchased directly from manufacturer or the official retailers of the companies on the recommended spare parts list
- contact manufacturer if it is necessary to handle the unit one year after its positioning on site or if you wish to dismantle it.

2 - Safety (continued)

2.7 Safety labels

Identification of the unit - Outside, on the left -hand front column

COD. PRODOTTO NEUTRO PRODUCT CODE		<input type="text"/>
MODELLO MODEL		<input type="text"/>
CE	1370	Panasonic
MANUFACTURER Panasonic Heating & Ventilation Air-Conditioning Italy S.r.l. Via XXV Aprile 29 20825 BARLASSINA MB ITALIA MADE IN ITALY		
MO.NO		<input type="text"/>
MATICOLA SERIAL NO.		<input type="text"/>
ANNO DI COSTRUZIONE Manuf. Year		<input type="text"/>
REFR.	GWP	CHARGE (kg) (tCO ₂ e)
		C1 C2 C3 C4
PS (LATO ALTA / LATO BASSA) PS (HIGH / LOW SIDE)		bar
TS (ALTA / BASSA) TS (HIGH / LOW)		°C
ALIM. POTENZA MAIN SUPPLY	V / PH / Hz	
CORRENTE DI SPUNTO LRA	(max)	A
CORRENTE A PIENO CARICO FLA	(max)	A
POTENZA ASSORBITA POWER INPUT	(max)	kW
PRESS. MAX ESERCIZIO ACQUA MAX WATER OPERATING PRESSURE		bar
MASSA MASS		kg
MODELLO: MODEL		COD.NO: P35952REV01
MATICOLA: SERIAL NO.	ANNO DI COSTRUZIONE Manuf. Year	
MATICOLA: SERIAL NO.	ANNO DI COSTRUZIONE Manuf. Year	

Pump operation - Outside, on the right-hand front column

LAS BOMBAS MONTADAS EN ESTA UNIDAD NO PUEDEN TRABAJAR SIN AGUA.
 DIE PUMPEN DIESES GERÄTES DÜRFEN NICHT OHNE WASSER BETRIEBEN WERDEN.
 THE PUMPS ON BOARD OF THIS UNIT CAN NOT WORK WITHOUT WATER.
 LES POMES A BORD DE CETTE UNITE NE PEUVENT PAS FONCTIONNER SANS EAU.
 LE POMPE A BORDO DI QUESTA UNITÀ NON POSSONO FUNZIONARE SENZA ACQUA.

Instruction for movement - Outside the packaging

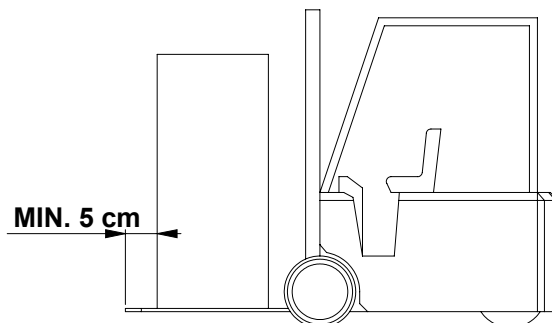

Phase sequence control on the electrical board

ATTENZIONE
 QUESTO COMPRESSORE RICHIEDE UN CORRETTO
 SENSO DI ROTAZIONE
 RISPETTARE LA CORRETTA SEQUENZA DELLE FASI
CAUTION
 THIS COMPRESSOR REQUIRES PROPER DIRECTION
 OF ROTATION
 CHECK PROPER ELECTRICAL PHASING
ACHTUNG
 KOMPRESSOREN BENÖTIGEN KORREKTES DREHFELD.
 ELEKTRISCHE ANSCHLÜSSE AUF DREHFELD ÜBERPRÜFEN
ATTENTION
 CES COMPRESSEURS NECESSITENT UN BON SENSE
 DE ROTATION
 VÉRIFIER LE CABLAGE DES PHASES
ATENCIÓN
 ESTOS COMPRESORES DEBEN FUNCIONAR EN EL
 SENTIDO DE ROTACIÓN CORRECTO
 COMPROBAR EL CABLEADO DE LAS FASES

Gravity centre - Base

TENERE SU QUESTA LINEA
 GANCIO DI SOLLEVAMENTO

KEEP LIFT HOOK
 ON THIS LINE

Instruction for the lifting

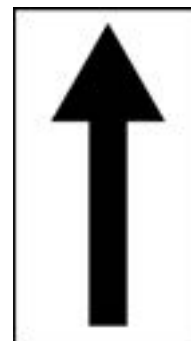

2 - Safety (continued)

Electrical warning
Adjacent to the master switch

	ATTENZIONE !	ATTENTION !
	Prima di aprire togliere tensione	Enlever l'alimentation électrique avant d'ouvrir
ACHTUNG !	CAUTION !	ATENCIÓN !
Vor öffnen des gehäuses hauptschalter ausschalten	Disconnect electrical supply before opening	Cortar la corriente antes de abrir el aparato

Commissioning - Outside, on the left-hand front column

Final Test Certificate - Inside the external door

QUALITY CHECK PROOF		
MODEL/TYPE	SERIAL NUMBER/PRODUCTION LOT	NUMBER CODE
MODELLO/TIPO	N° DI SERIE/LOTTO DI PRODUZIONE	CODICE
		MANUFACTURED YEAR
		ANNO DI COSTRUZIONE
NUMBER CHECK	DESCRIPTION OF INSPECTION	INSPECTOR REFERENCE
NUMERO CONTROLLI	DESCRIZIONE DEI TEST DI CONTROLLO	TIMBRO OPERATORE
01	PRELIMINARY PROOF PRESSURE TEST AND LEAK TEST WITH ELIUM AND NITROGEN AT MINIMUM 10 BAR (REFRIGERANT SIDE) IN COMPLIANCE WITH TEST SPECIFICATION - MARK WITH PENS PRIMA PRELIMINARE DI PRESSIONE E TENUTA CIRCUITO CON ELIO (E ADITO AD ALMENO 10 BAR (LATO REFRIGERANTE), IN ACCORDO ALLA SPECIFICA DI COLLAUDO - SEGNARE CON PENNARELLO CARRY OUT AN ADDITIONAL LEAK TEST WITH ELIUM AND NITROGEN AT 2,5 BAR (WATER SIDE) - MARK WITH PENS EFFETTUARE UNA PROVA PRELIMINARE DI TENUTA CON ELIO E ADITO A 2,5 BAR (LATO ACQUA) - SEGNARE CON PENNARELLO	
02	VACUUM TEST CARRIED OUT VUOTO ESEGUITO	
03	REFRIGERANT CHARGE CARICA REFRIGERANTE	
04	CHECK WIRING CABLE CONNECTION VERIFICA CARIABGGO ELETTRICO	
05	SAFETY TEST: CONTINUITY, INSULATION, DIELECTRICAL STRENGTH PROVE DI SICUREZZA: CONTINUITA', ISOLAMENTO, RIGIDITA'	
06	RUNNING TEST WITH SAFETY DEVICES COLLAUDO FUNZIONALE COMPLETO CON INTERVENTO SICUREZZA (RUEVI)	
07	LEAK TEST ON REFRIGERANT CIRCUIT DURING RUNNING CONDITION - MARK WITH PEN VERIFICA TENUTA CIRCUITO REFRIGERANTE DURANTE IL FUNZIONAMENTO - SEGNARE CON PENNARELLO	
08	FINAL LEAK TEST ON REFRIGERANT CIRCUIT AFTER RUNNING - MARK WITH PENS VERIFICA FINALE TENUTA CIRCUITO REFRIGERANTE DOPO IL COLLAUDO FUNZIONALE - SEGNARE CON PENNARELLO	
09	CHECK ASSEMBLY PARTS VERIFICA ASSEMBLAGGIO PARTI	
10	CHECK MOUNTED ACCESSORIES OR SUPPLY LOOSE CONTROLO ACCESSORI MONTATI E/O FORNITI A BORDO UNITA'	
11	CHECK FOCUS SUPPLY (E.G. I/O), START UP FORM, WIRING DIAGRAM, RULE VERIFICA DOCUMENTI FORNITI CON L'UNITA'	
12	CHECK STICKERS, LABELLING VERIFICA TARGHETTE	
13	AESTHETICAL CHECK AND CLEANING CONTROLO ESTETICO/PULIZIA	
14	CHECK TEST SHEET AND CHECK LIST FILLED UP CONTROLO COMPILAZIONE SCHEDA DI COLLAUDO E CHECK LIST	

Grounding connection on the electrical board, adjacent to the connection

Read the instruction on the electrical board

Fitting identification - Adjacent to fittings

2 - Safety (continued)

Identification of refrigerant - Below identification of the unit

Contains fluorinated greenhouse gases covered by the Kyoto-Protocol.
 Contiene gas fluorurati ad effetto serra disciplinati dal Protocollo di Kyoto.
 Contient des gaz à effets de serre fluorés couverts par le Protocol de Kyoto.
 Enthält fluorierte Treibhausgase die vom Kyoto-Protokoll erfasst sind.
 Contiene gases fluorados de efecto invernadero cubiertos por el Protocolo de Kyoto.

Parameter configuration - Inside the electrical board

IMPORTANT !

NOTE: always check configuration parameters value setting after any reset or Control Board replacement.

NOTA: controllare sempre valori parametri configurazione dopo ogni reset o sostituzione scheda controllo.

ANMERKUNG: nach jeder Rücksetzung oder nach dem Ersatz der Steuerkarte immer die Konfigurationsparameterwerte prüfen.

NOTE: contrôler toujours les valeurs des paramètres de configuration après chaque remise à zéro ou remplacement de la carte de contrôle.

NOTA: controlar siempre los valores de los parámetros de configuración después de cada puesta a cero o sustitución de la tarjeta de control.

Pump drain - Outside, on the right-hand front column

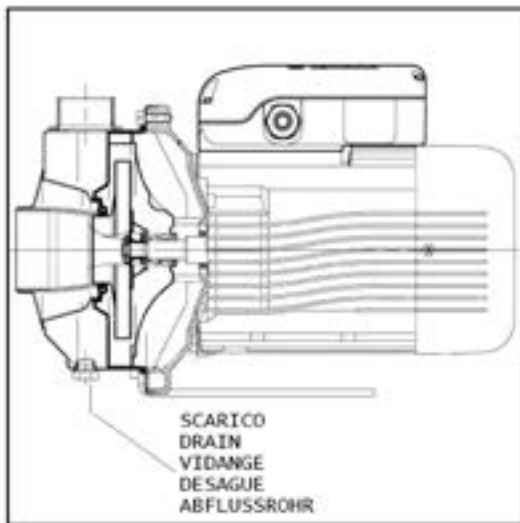

Circuit drain - Outside, on the right-hand front column



ATTENTION! Don't leave the unit with water inside hydraulic circuit during winter or when it is in stand by.
ATTENZIONE! Non lasciare l'unità con acqua nel circuito idraulico durante l'inverno o quando non è funzionante.
ATTENTION! Ne laissez pas l'unité avec de l'eau dans le circuit hydraulique pendant l'hiver ou quand elle ne travaille pas.
WARNUNG! Lassen Sie nicht das Wasser in die Schaltung während des Winters oder wenn es nicht funktioniert.
¡ATENCIÓN! No deje el agua en el circuito hidráulico durante el invierno o cuando no está trabajando.

Filter / flow switch - Outside, on the right-hand front column



E' OBBLIGATORIO L'USO DI FILTRO E FLUSSOSTATO ACQUA
THE USE OF FILTER AND FLOW SWITCH IS MANDATORY
EL USO DEL FILTRO Y DEL INTERRUPTOR DE FLUJO ES OBLIGATORIO
L'UTILISATION DU FILTRE ET DU FLUXOSTAT EST OBLIGATOIRE
DER GEBRAUCH VON FILTER UND STRÖMUNGSWÄCHTER IST VORGESCHRIEBEN.

Risk of Asphyxia



Pressurized Equipment

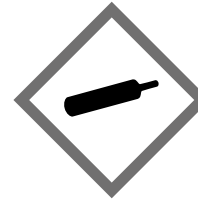

Warning - High temperature zone adjacent to hot pipes or components



2 - Safety (continued)

2.8 Safety regulations

REFRIGERANT DATA	SAFETY DATA: R410A
Toxicity	Low
Contact with skin	<p>If sprayed, the refrigerant is likely to cause frost burns. If absorbed by the skin, the danger is very limited; it may cause a slight irritation, and the liquid is degreasing. Unfreeze the affected skin with water. Remove the contaminated clothes with great care - in the presence of frost burns, the clothes may stick to the skin. Wash the affected skin with plenty of warm water.</p> <p>In the presence of symptoms such as irritation or blisters, obtain medical attention.</p>
Contact with eyes	Vapours do not cause harmful effects. The spraying of refrigerant may cause frost burns. Wash immediately with a proper solution or with tap water for at least 10 minutes, and then obtain medical attention.
Ingestion	<p>Very unlikely - should something happen, it will cause frost burns.</p> <p>Do not induce vomiting. Only if the patient is conscious, wash out mouth with water and give some 250 ml of water to drink. Then, obtain medical attention.</p>
Inhalation	<p>R410A: remarkable concentrations in the air may have an anaesthetic effect, and cause fainting.</p> <p>The exposure to considerable amounts may cause irregular heartbeat, and sudden death of the patient. Very high concentrations may result in the risk of asphyxia, due to the reduction in the oxygen percentage in the atmosphere. Remove the patient to fresh air and keep warm and at rest.</p> <p>If necessary, give oxygen. In case of breathing difficulties or arrest, proceed with artificial respiration.</p> <p>In case of cardiac arrest, proceed with cardiac massage, while waiting for medical attention to arrive.</p>
Recommendations	Semiotics or support therapy is recommended. Cardiac sensitisation has been observed that, in the presence of circulating catecholamines such as adrenalin, may cause cardiac arrhythmia and accordingly, in case of exposure to high concentrations, cardiac arrest.
Prolonged exposure	<p>R410A: a study on the effects of exposure to 50,000 ppm during the whole life of rats has identified the development of benign testicle tumour.</p> <p>This situation should therefore be negligible for personnel exposed to concentrations equal to or lower than professional levels.</p>
Professional levels	R410A: Recommended threshold: 1,000 ppm v/v - 8 hours TWA.
Stability	R410A: Not specified
Conditions to avoid	Do not use in the presence of flames, burning surfaces and excess humidity.
Hazardous reactions	<p>May react with sodium, potassium, barium and other alkaline metals.</p> <p>Incompatible substances: magnesium and alloys with magnesium concentrations > 2%.</p>
Hazardous decomposition products	R410A: Halogen acids produced by thermal decomposition and hydrolysis.

2 - Safety (continued)

2.8 Safety regulations (continued)

REFRIGERANT DATA	SAFETY DATA: R410A
General precautions	Do not inhale concentrated vapours. Their concentration in the atmosphere should not exceed the minimum preset values and should be maintained below the professional threshold. Being more weighty than the air, the vapour concentrates at low level, in narrow areas. Therefore, any exhaust system must work at low level.
Respiratory system protection	If you are in doubt about the concentration in the atmosphere, it is recommended to wear a respirator approved by an accident-prevention Authority, of the independent or oxygen type.
Storage	Cylinders must be stored in a dry and cool place, free from any fire hazard, far from direct sunlight or other sources of heat, radiators etc. Keep a temperature below 50 °C.
Protective clothing	Wear overalls, protective gloves and goggles or a mask.
Accidental release measures	It is important to wear protective clothing and a respirator. Stop the source of the leak, if you can do this without danger. Negligible leaks can be left evaporating exposed to the sun, providing that the room is well ventilated. Considerable leaks: ventilate the room. Reduce the leak with sand, earth or other absorbing substances. Make sure that the liquid does is not channelled into gutters, sewers or pits where the vapours are likely to accumulate and create a dangerous atmosphere .
Disposal	The best method is recovery and recycling. If this method is not practicable, dispose according to an approved procedure, that shall ensure the absorption and neutralization of acids and toxic agents.
Fire fighting information	R410A: Not flammable in atmosphere.
Cylinders	The cylinders, if exposed to fire, shall be cooled by water jets; otherwise, if overheated, they may explode.
Protective fire fighting equipment	In case of fire, wear an independent respirator and protective clothing.

2 - Safety (continued)

2.8 Safety regulations (continued)

LUBRICANT OIL DATA	SAFETY DATA: POLYESTER OIL (POE)
Classification	Not harmful.
Contact with skin	May cause slight irritation. Does not require first aid measures. It is recommended to follow usual personal hygiene measures, including washing the exposed skin with soap and water several times a day. It is also recommended to wash your overalls at least once a week.
Contact with eyes	Wash thoroughly with a suitable solution or tap water.
Ingestion	Seek medical advice immediately.
Inhalation	Seek medical advice immediately.
Conditions to avoid	Strong oxidising substances, caustic or acid solutions, excess heat. May corrode some types of paint or rubber.
Protection of the respiratory system	Use in well ventilated rooms.
Protective clothing	Always wear protective goggles or a mask. Wearing protective gloves is not mandatory, but is recommended in case of prolonged exposure to refrigerant oil.
Accidental release measures	It is important to wear protective clothing, especially goggles. Stop the source of the leak. Reduce the leak with absorbing substances (sand, sawdust or any other absorbing material available on the market).
Disposal	The refrigerant oil and its waste will be disposed of in an approved incinerator, in conformity with the provisions and the local regulations applicable to oil waste.
Fire fighting information	In the presence of hot liquid or flames, use dry powder, carbon dioxide or foam. If the leak is not burning, use a water jet to remove any vapours and to protect the personnel responsible for stopping the leak.
Cylinders	Cylinders exposed to a fire shall be cooled with water jets.
Fire fighting protective equipment	In case of fire, wear an independent respirator.

3 - Transport, Lifting and Positioning

The units are supplied fully assembled and tested (except for accessories supplied loose in the units – absorbers, filter, etc.). They are ready to be installed and started on the field.

R410A units are only charged with liquid refrigerant and with oil in the quantity required for operation.



The low pressure side of the refrigerating circuit on R410A units shall be charged by means of the service valve arranged on the thermal expansion valve before the device is operated.

3.1 Inspection

The unit shall be immediately inspected upon receipt to check for any damage since it has been delivered ex works and transported at the customer's risk. It is also necessary to make sure that all the parcels specified on the delivery note have been delivered.

Any damage you may find shall be immediately reported in writing to the carrier. Even if the damage is only on the surface, please also notify the manufacturer's local representative.

The manufacturer disclaims all responsibility for the shipment even if it has provided for its organisation.

3.2 Handling

The units are designed to be lifted from above, by means of cables and eyebolts. A spacer shall be arranged between the cables to prevent them from damaging the unit (see the figure aside).

Before handling the devices, make sure the site you have chosen for the installation can withstand its weight and support its mechanical impact.

Avoid touching sharp parts while handling the unit.



The unit shall never be placed on rollers.

Act as follows to lift and handle the unit:

- Insert and secure the eyebolts into the frame holes which have been marked for this purpose.
- Connect the cables to the eyebolts.
- Insert the spacer between the cables.
- Provide for hooking at the centre of gravity of the device.
- Cables shall have such a length that the angle they form with the horizon when under tension is not less than 45°.

Space requirements request to handling

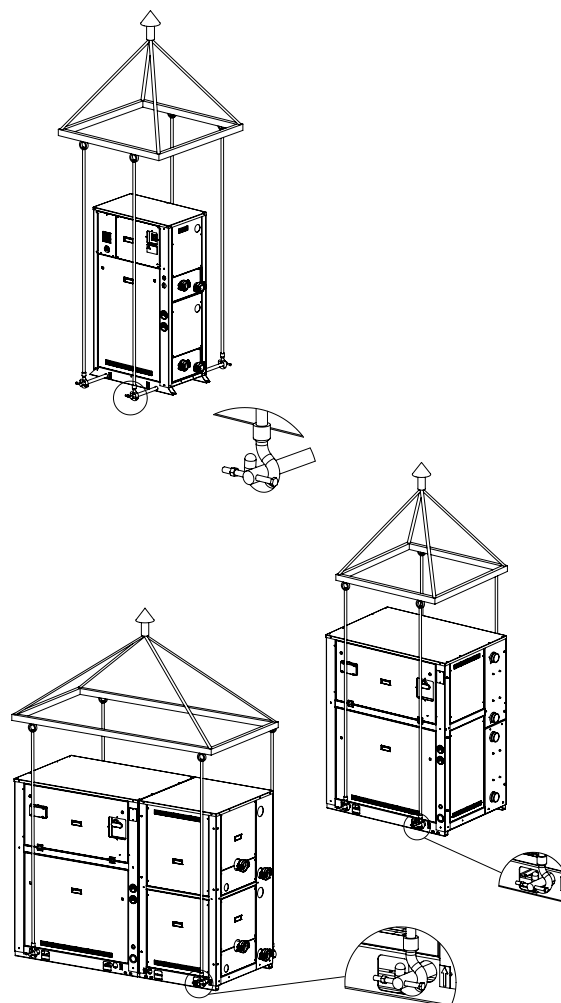
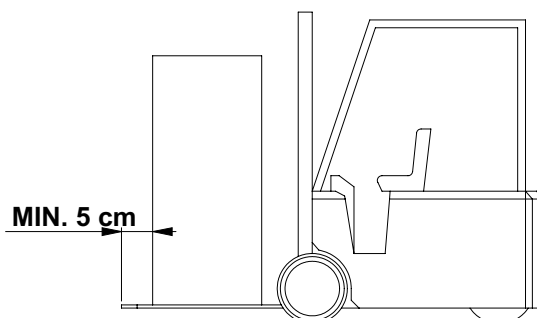

While lifting and handling the unit, pay attention. The sides of the unit shall be protected by cardboard or plywood sheets.

3 - Transport, Lifting and Positioning

3.3 Anchoring

It is not essential to secure the unit to the foundations, unless in areas where there is a serious risk of earthquake, or if the appliance is installed on the top of a steel frame.

3.4 Storage

If the unit is to be stored for some time before installation, take at least the following precautions to prevent damage, corrosion and/or deterioration:

- Make sure all openings, such as for example water connections, are well plugged and sealed.
 - Never store the units in a room where temperature is above 50 °C (R410A units) or where the units are directly exposed to the sunlight.
- Minimum storage temperature is -25 °C.
 - Store the units in areas where minimum activity is likely to take place in order to avoid any risk of accidental damage.
 - Never use steam to clean the unit.
 - Remove all the keys required to have access to the control panel and give them to the person in charge of the field.
 - It is also recommended to provide for visual inspections at regular intervals.

4 - Installation

4.1 Positioning of the unit



Before installing the unit, make sure that the structure of the building and/or the supporting surface can withstand the weight of the appliance. The weight of the units are listed in Chapter "8 - Technical Data" of this manual.

These units have been designed for indoor installation on a solid surface. Standard accessories include antivibrating rubber supports, that must be positioned under the base.

When the unit is to be installed on the ground, it is necessary to provide a concrete base, to ensure a uniform distribution of the weight.

As a general rule, no special sub-base is required. However, if the unit is to be installed above inhabited rooms, it is advisable to rest it on spring shock absorbers (optional), that will minimise the transmission of any vibration to the building structure.

When choosing the place of installation, bear in mind that:

the unit must not be installed in areas subject to flooding, under gutters etc.

the place of installation must allow all necessary space for air circulation and maintenance operations (see Chapter "8 - Technical Data").

4.2 Spring Isolator Installation

- Prepare the base, that must be flat and level.
- Lift the appliance and insert shock absorbers as follows:

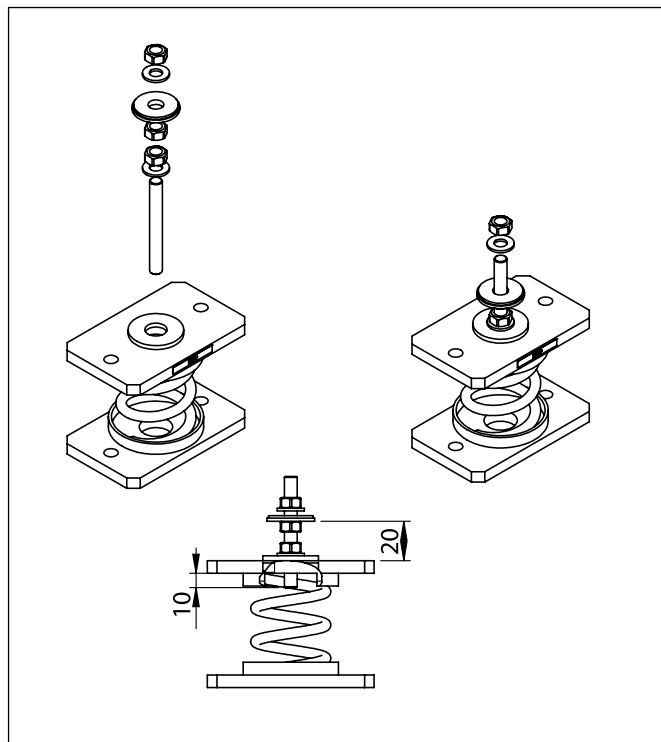

1. Proceed to assemble the jack components. Fit the jack in the threaded housing on the upper plate of the antivibration mount.

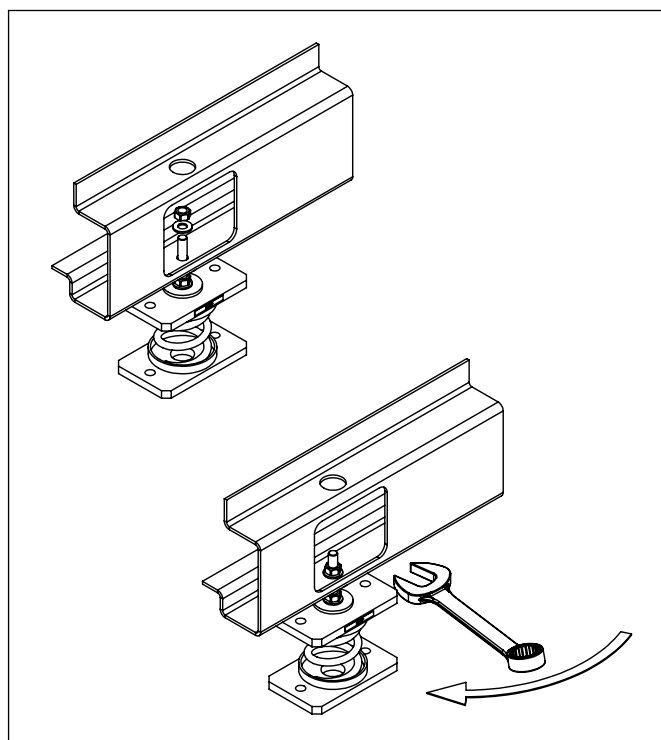

2. Install the jack on the antivibration mount in the corresponding hole in the machine base.

4 - Installation (continued)

4.3 Internal / external Water Circuit

The flow switch and the filter water, although not included in the supply, must always be fitted such as plant components.

Their installation is mandatory for warranty.



The software managing the water cooled range is featuring, by default, a logic function by-passing any water flow alarm when occurring on the source heat exchanger during the cooling operation of the unit. This is because many water-cooled applications are working with modulation of the water flow due to the cold temperature of the media (city network in example), and this could generate fake water flow alarm conditions. In case the unit is heat pump type, reversing the cycle on the refrigerant side, the alarm comes enabled because the heat exchanger changes its role (from condenser to evaporator) and operation with poor water flow rate could generate a dangerous condition (heat exchanger freezing for example).

For those specific applications where it is mandatory to protect the source heat exchanger during the cooling operation, it is possible to connect an external water flow protection device (water flow switch / water pressure switch) to the connection 05A-05 (user terminal QG - Y1). This additional protection, mounted in series with the plant side heat exchanger protection, would generate alarm condition in case of operation with poor water flow rate.



The internal / external water circuit shall guarantee a constant water flow rate through the circulating refrigerant / water heat exchangers under steady operating conditions and in case of a load variation.

The circuit shall be composed by the following elements:

A circulation pump which can ensure the necessary flow rate and head.

The total content of the primary water circuit shall never be lower than 5 l/kW in terms of refrigerating capacity. If the total water volume in the primary circuit should be unable to reach such a value, an additional heat-insulated storage tank should be installed. This tank is intended to avoid any repetitive start of the compressor.

A membrane expansion tank complete with a safety valve and a drain which shall be visible.



The expansion tank shall be dimensioned in such a way that it can absorb a 2% expansion of the total volume of the water in the plant (exchanger, pipelines, uses and storage tank, if available).

The expansion tank shall never be insulated when the circulating fluid is not flowing through it.

A water pressure differential switch is mounted as a standard. It will stop the unit whenever a flow rate problem occurs.

In addition:

- Install on/off valves (accessory) on the lines at the inlet and outlet of the manifolds of the exchangers.
- Arrange a by-pass complete with an on/off valve between the manifolds of the heat exchangers.
- Arrange air vent valves at the high points of the water lines.
- Arrange drain points complete with plugs, clocks, etc. in the proximity of the low points of the water lines.
- Insulate the water lines to prevent the heat from blowing back into the unit.

RECOMMENDED WATER COMPOSITION

PH	7.5 - 9	
Electrical conductivity	10 - 500	µS/cm
Total hardness	4.5 - 8,5	dH
Temperature	< 60	[°C]
Alkalinity (HCO ₃ ⁻)	70-300	ppm
Alkalinity / Sulphates (HCO ₃ ⁻ / SO ₄ ²⁻)	> 1	ppm
Sulphates (SO ₄ ²⁻)	< 70	ppm
Chlorides (Cl ₋)	< 50	ppm
Free Chlorine	< 0.5	ppm
Phosphates (PO ₄ ³⁻)	< 2	ppm
Ammonia (NH ₃)	< 0.5	ppm
Ammonium Ion (NH ₄ ⁺)	< 2	ppm
Manganese Ion (Mn ²⁺)	< 0.05	ppm
Free Carbon Dioxide (CO ₂)	< 5	ppm
Hydrogen Sulfide (H ₂ S)	< 0.05	ppm
Oxygen Content	< 0.1	ppm
Nitrates (NO ₃ ⁻)	< 100	ppm
Manganese (Mn)	< 0.1	ppm
Iron (Fe)	< 0.2	ppm
Aluminium (Al)	< 0.2	ppm

Caution

If the water circuit is to be drained for a time exceeding one month, the circuit must be fully charged with nitrogen to prevent any risk of corrosion by differential venting

4 - Installation (continued)

ECOi-W WQ 20-45 C/H

BASIC HYDRAULIC SYSTEM

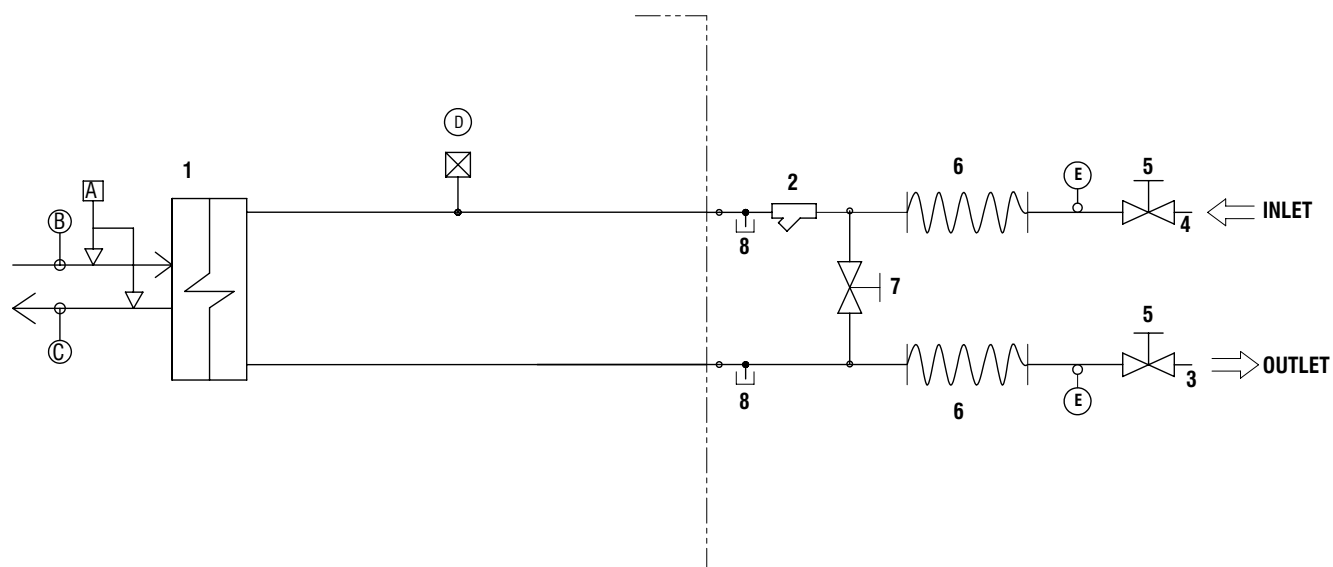

COMPONENTS	
1	Plate heat exchanger
2	Water filter
3	Water outlet
4	Water inlet
5	Globe valve
6	Flexible pipes
7	By-pass valve
8	Pressure point/drainage

SAFETY / CONTROL DEVICES	
A	Water differential pressure switch (50 mbar)
B	Inlet water temperature sensor
C	Outlet water temperature sensor
D	Vent valve
E	Thermometer
----	Unit side
o	Probes

4 - Installation (continued)

ECOi-W WQ 20-45 C/H

HYDRAULIC SYSTEM 1P-CONDENSER

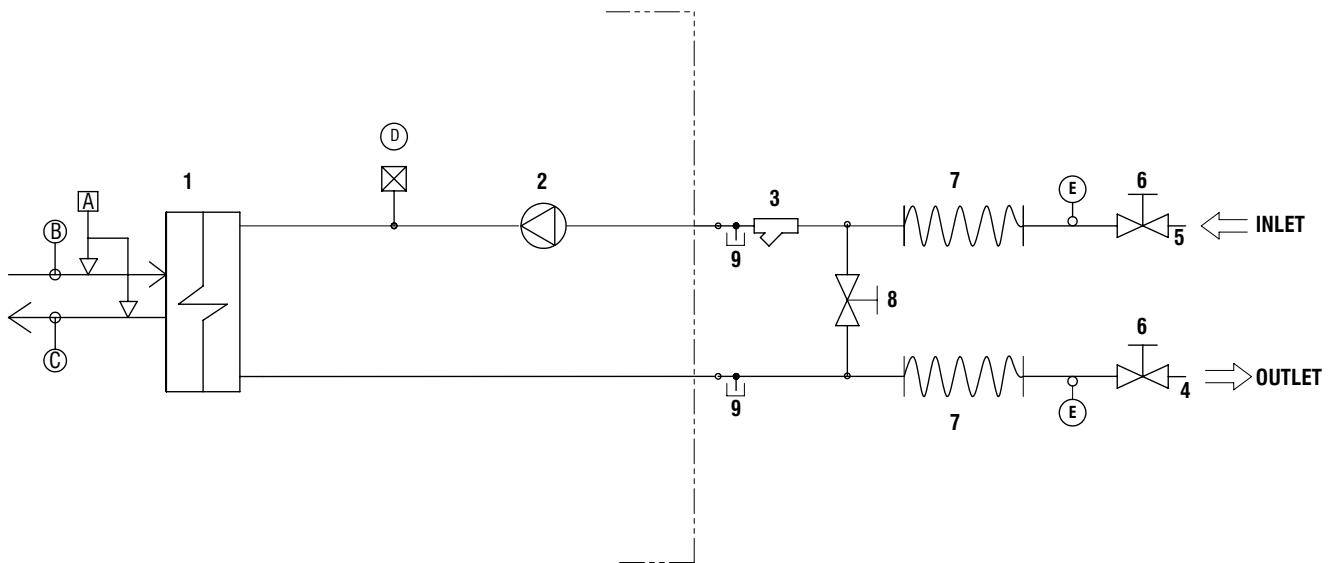

COMPONENTS	
1	Plate heat exchanger
2	Pump
3	Water filter
4	Water outlet
5	Water inlet
6	Globe valve
7	Flexible pipes
8	By-pass valve
9	Pressure point/drainage

SAFETY / CONTROL DEVICES	
A	Water differential pressure switch (50 mbar)
B	Inlet water temperature sensor
C	Outlet water temperature sensor
D	Vent valve
E	Thermometer
----	Unit side
o	Probes

4 - Installation (continued)

ECOi-W WQ 20-45 C/H

HYDRAULIC SYSTEM 1P-EVAPORATOR

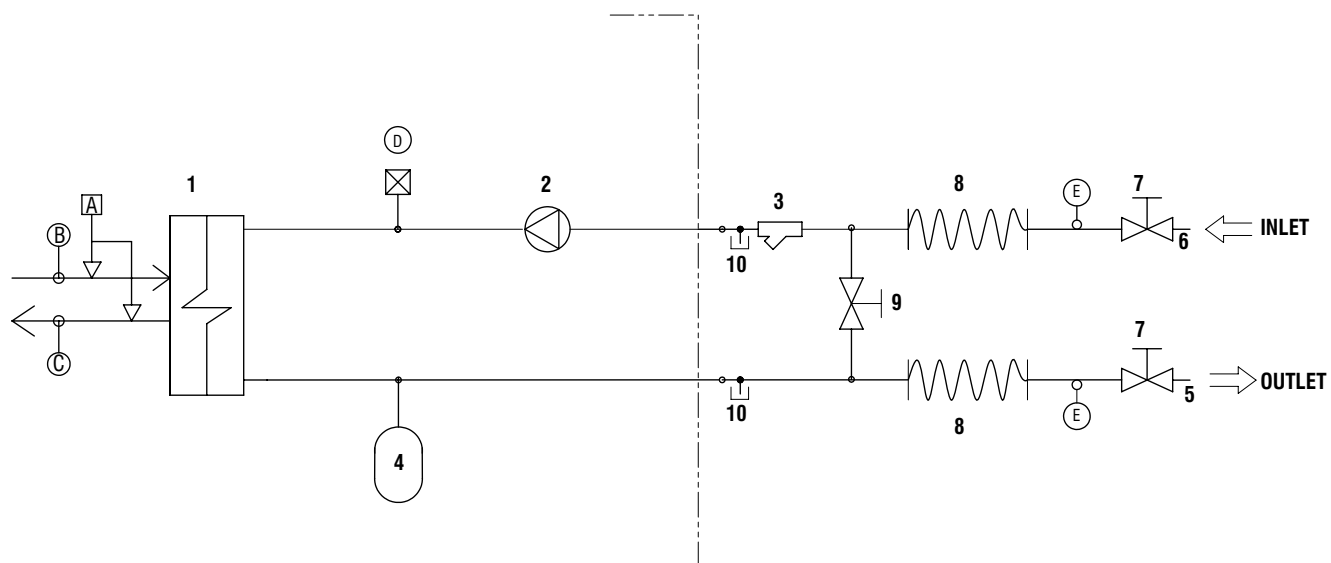

COMPONENTS	
1	Plate heat exchanger
2	Pump
3	Water filter
4	Pressure expansion tank
5	Water outlet
6	Water inlet
7	Globe valve
8	Flexible pipes
9	By pass valve
10	Pressure point/drainage

SAFETY / CONTROL DEVICES	
A	Water differential pressure switch (50 mbar)
B	Inlet water temperature sensor
C	Outlet water temperature sensor
D	Vent valve
E	Thermometer
----	Unit side
o	Probes

4 - Installation (continued)

ECOi-W WQ 50-190 C/H

BASIC HYDRAULIC SYSTEM

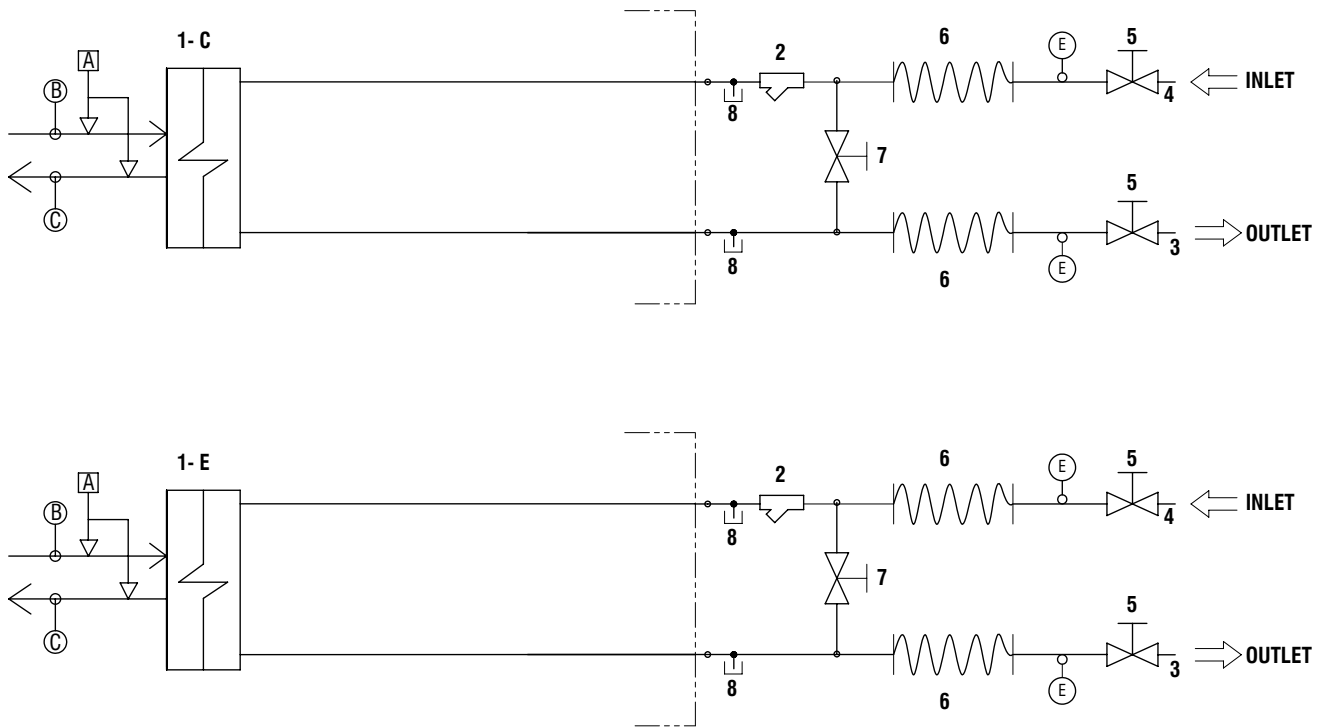

COMPONENTS	
1C	Condenser
1E	Evaporator
2	Water filter
3	Water outlet
4	Water inlet
5	Globe valve
6	Flexible pipes
7	By pass valve
8	Pressure point / drainage

SAFETY / CONTROL DEVICES	
A	Water differential pressure switch (50 mbar)
B	Inlet water temperature sensor
C	Outlet water temperature sensor
D	Vent valve
E	Thermometer
----	Unit side
o	Probes

4 - Installation (continued)

ECOi-W WQ 50-190 C/H

HYDRAULIC SYSTEM 1P-CONDENSER 1P-EVAPORATOR

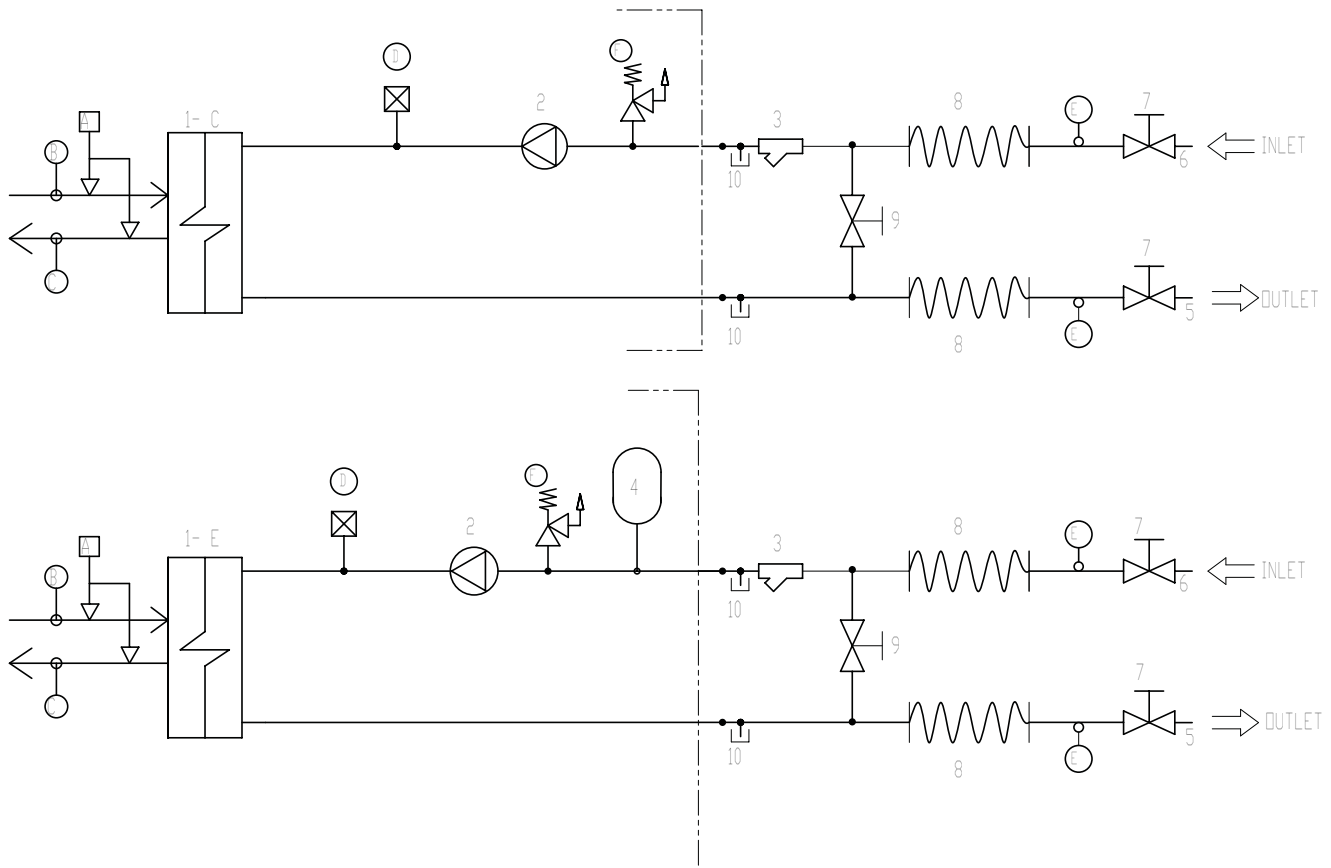

COMPONENTS	
1C	Condenser
1E	Evaporator
2	Pump
3	Water filter
4	Pressure expansion tank
5	Water outlet
6	Water inlet
7	Globe valve
8	Flexible pipes
9	By pass valve
10	Pressure point / drainage

SAFETY / CONTROL DEVICES	
A	Water differential pressure switch (50 mbar)
B	Inlet water temperature sensor
C	Outlet water temperature sensor
D	Vent valve
E	Thermometer
F	Water safety valve (6 bar)
----	Unit side
o	Probes

4 - Installation (continued)

ECOi-W WQ 50-190 C/H

HYDRAULIC SYSTEM 2P-CONDENSER 2P-EVAPORATOR

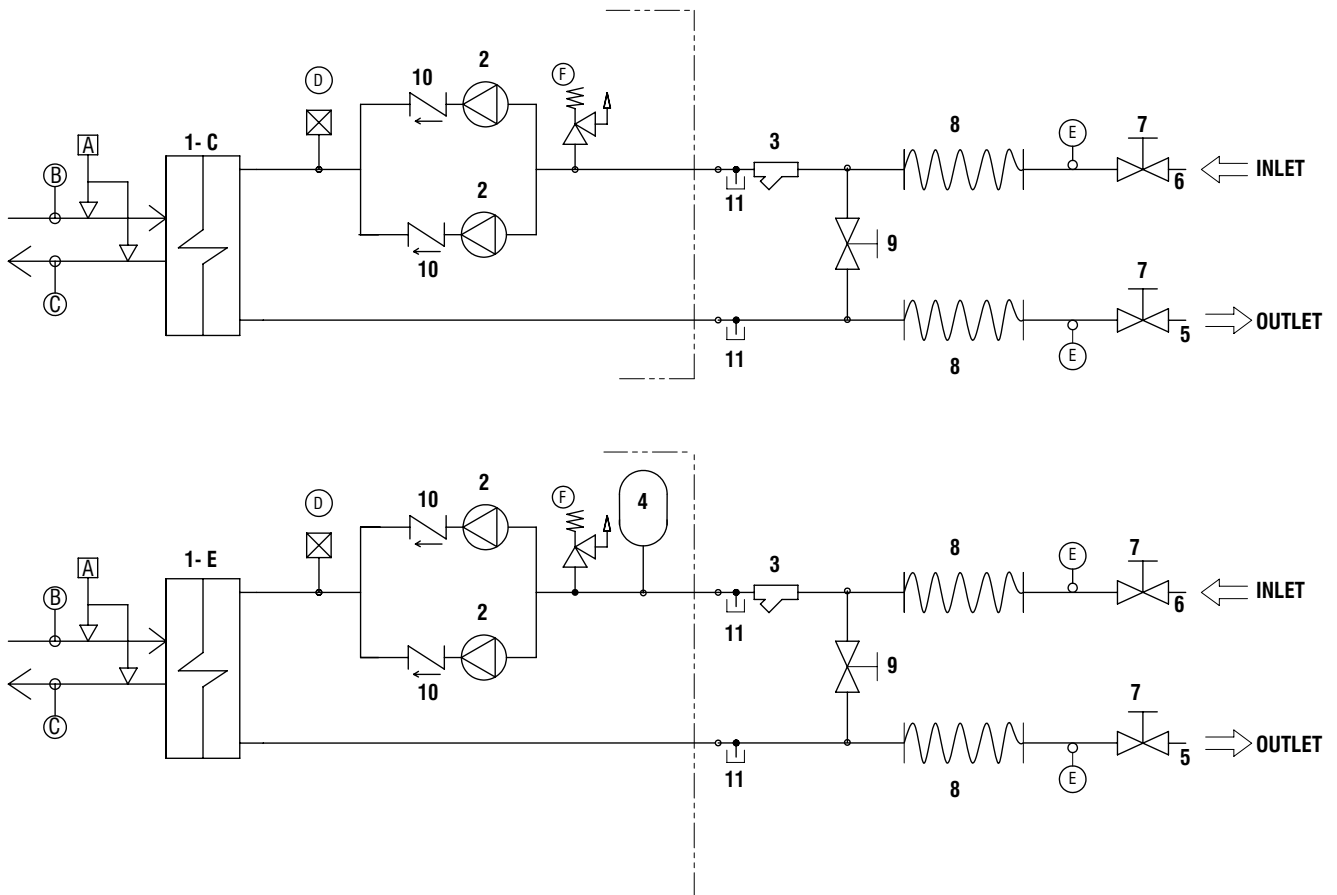

COMPONENTS	
1C	Condenser
1E	Evaporator
2	Pump
3	Water filter
4	Pressure expansion tank
5	Water outlet
6	Water inlet
7	Globe valve
8	Flexible pipes
9	By pass valve
10	Non-return valve
11	Pressure point / drainage

SAFETY / CONTROL DEVICES	
A	Water differential pressure switch (50 mbar)
B	Inlet water temperature sensor
C	Outlet water temperature sensor
D	Vent valve
E	Thermometer
F	Water safety valve... (6 bar)
----	Unit side
o	Probes

4 - Installation (continued)

4.4 Water connections

	<p>The attachments at the water inlet and outlet shall be connected in compliance with the instructions which can be found on the labels in the proximity of the attachments.</p>
---	---

Connect the water lines of the plant with the attachments of the unit whose diameters and positions are shown in Chapter "8 - Technical Data".

4.5 Power supply

	<p>Before carrying out any operations on the electrical system, make sure that the unit is de-energised.</p>
---	--

	<p>It is important that the appliance is grounded.</p>
---	--

	<p>The company in charge of the installation shall conform to the standards applicable to outdoor electrical connections.</p>
---	---

The manufacturer may not be held liable for any damage and/or injury caused by failure to comply with these precautions.

The unit conforms to EN 60204-1.

The following connections shall be provided:

- A 3-phase and grounding connection for the power supply circuit.
- The electrical distribution system shall meet the power absorbed by the appliance.
- The disconnecting and magnetothermal switches must be sized to control the starting current of the unit.
- The power supply lines and the insulation devices must be designed in such a way that every line is independent.
- It is recommended to install differential switches, to prevent any damage caused by phase drops.
- The compressors are supplied through contactors controlled from the control panel.
- Each motor is provided with an internal safety thermal device and external fuses.
- The power supply cables must be inserted into dedicated openings on the front of the unit, and will enter the electrical board through holes drilled on the bottom of the board.

4 - Installation (continued)

4.6 Electrical connections

The unit must be installed on site according to the Machinery Directive 2006/42/EC, Electromagnetic Compatibility Directive 2014/30/EU and the usual procedures and standards applicable in the place of installation.

The unit must not be operated if the installation has not been carried out according to the instructions provided in this manual.

The power supply lines must consist of insulated copper conductors, dimensioned for the maximum absorbed current.

Connection to terminals must be performed according to the diagram of connections (User's Terminal Box) provided in this manual and according to the wiring diagram which accompanies the unit.

	<p>Before connecting the power supply lines, check that the available voltage value does not exceed the range specified for the electrical data (Chapter "8 - Technical Data").</p>
---	--

For 3-phase systems, check also that the imbalance between the phases does not exceed 2%. To perform this check, measure the differences between the voltage of each phase couple and their mean value during operation.

The maximum % value of these differences (imbalance) must not exceed 2% of the mean voltage.

If the imbalance is unacceptable, contact the Energy Distributor to solve this problem.

	<p>Supplying the unit through a line whose imbalance exceeds the permissible value will automatically void the warranty.</p>
---	---

4 - Installation (continued)

Electrical Connections

QG - Y1

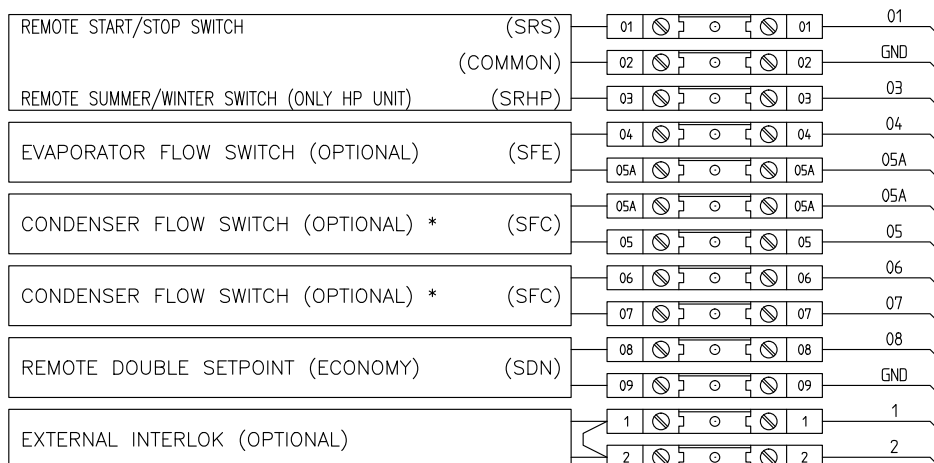

QG - Y2

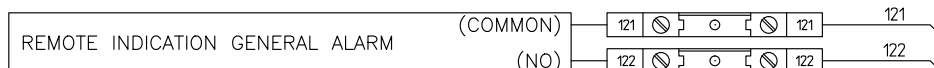

QG - Y3

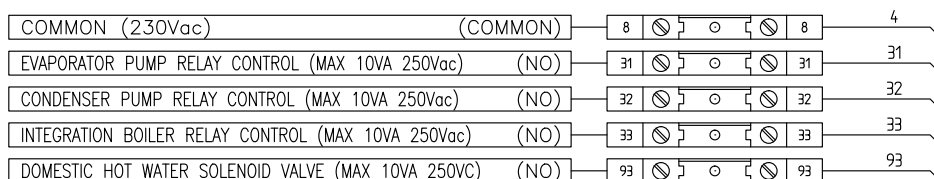

QG - Y4

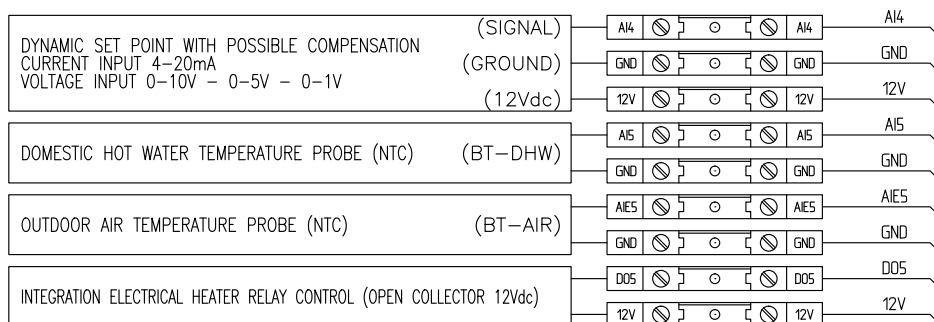

QG - Y5

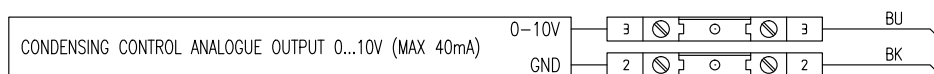

MORSETTIERA UTENTE / USER TERMINALS

* Terminals block "05A" - "05": Condenser flow switch terminals as a standard
 Terminals block "06" - "07": Condenser flow switch terminals for well water application

5 - Start-Up

	<p>The unit must be started for the first time by personnel suitably trained by one Authorised Service Centre. Failure to meet this requirement will immediately void the warranty.</p>
---	--

	<p>The operations carried out by authorised personnel are limited to the start-up of the unit, and do not include any other operation on the plant, such as, for example, electrical and hydraulic connections etc.</p> <p>All the other operations before start-up, including oil pre-heating for at least 12 hours, must be performed by the Installer.</p>
---	---

5.1 Preliminary check

The checks listed below shall be performed before starting the unit and before the arrival of the authorised personnel.

- Check the section of power supply and grounding cables; make sure that terminals are tightened and check the correct operation of contactors, with the main switch open.
- Check that any voltage and phase variation in the power supply does not exceed the prefixed thresholds.
- Connect the contacts of the flow switch and the thermal relay of the pump and of the other devices (if any) as shown on the electrical connection diagram on page 26.
- Check the components of the external water circuit (pump, user equipment, filters, power supply tank and reservoir, if any) have been installed properly, and according to the manufacturer's instructions.
- Check the filling of the hydraulic circuits, and make sure that the fluid circulation is correct, without any trace of leaks and air bubbles. If you use ethylene glycol as antifreeze, check that its percentage is correct (do not exceed 35% glycol percentage).
- Check the direction of rotation of the pumps is correct, and that fluids have been circulating for at least 12 hours for both pumps. Then, clean the filters on the suction side of the pumps.
- Adjust the liquid distribution network in such a way that the flow rate is within the specified range.
- Check that the water quality meets with the required specifications.
- Please remove all enclosed manuals before turn-on the unit.
- Check that oil heaters, if any, have been turned on at least 12 hours before start-up.

5.2 Start-up

Start-up sequence:

- Turn on the Main switch (at least 12 hours before start-up).
- Check that the oil in the compressor has reached the requested temperature (the minimum temperature outside the pan must be approx. 40°C) and that the auxiliary control circuit is energised.
- Check the operation of all the external equipment, and make sure that the control devices of the plant are properly calibrated.
- Start the pump and check that water flow is correct.
- Set the desired fluid temperature on the control board.
- Start the appliance (see Chapter "6 - Control").
- Check the correct direction of rotation of compressors. Scroll compressors cannot compress the refrigerant when they rotate in the opposite direction. To make sure that they are rotating in the correct direction, simply check that, just after the start-up of the compressor, the pressure drops on the SP side and rises on the HP side. Furthermore, if a scroll compressor rotates in the opposite direction, there is a considerable rise in the sound level of the unit, as well as in a dramatic reduction of current absorption compared to normal values. In case of wrong rotation, the scroll compressor can be irrevocably damaged. Phase monitor is assembled in the unit as a standard to prevent wrong compressors rotation.
- After about 15 minutes of operation, check there are no bubbles through the sight glass on the liquid line.

	<p>The presence of bubbles may indicate a part of the refrigerant charge has been released in one or more points. It is important to remove these leaks before proceeding.</p>
---	---

- Repeat the start-up procedure after removing the leaks.

5 - Start-Up (continued)

5.3 Checking the operation

Check the following:

The temperature of the water entering the evaporator / condenser.

The temperature of the water leaving the evaporator / condenser.

The level of the water flow rate in the evaporator / condenser.

The current absorption upon the start of the compressor as well as in a stabilised operation.

Check the condensing and evaporation temperatures during operation at high and low pressure, detected by the pressure gauges of the refrigerant, are within the following range:

(On the units not provided with HP / SP pressure gauges for the refrigerant, connect a pressure gauge to the Schrader valves on the refrigeration circuit).

HP side	Approx. 3-5 °C above the temperature of water leaving the condenser, for R410A units.
SP side	Approx. 2 to 4 °C below the temperature of the leaving chilled water, for R410A units.

5.4 Delivery to the customer

Train the user according to the instructions provided in Section "6 - Control".

6 - Control

6 General information

Introduction

This document contains the information and the operating instructions for the units.

Main characteristics

- simple user interface with possibility to customize keys functions and to set menu visibility
- parameter setting through keyboard or PC
- thermoregulation → inlet / outlet water probe, according to customer need / application
- auto-adaptive set-point
- dynamic set-point
- sanitary hot water and anti-legionella weekly scheduling
- alarm log
- analogue input (to be set) → NTC, 4..20mA, 0..1V, 0..5V, 0..10V
- digital input → to be set by parameter
- automatic changeover
- 0-10V analogue condensation control
- boiler / electrical resistances management for heating integration
- electrical resistance management for sanitary hot water
- advanced pump management (internal / external circuit)

The following accessories can be also connected :

- Multi-Function Key (MFK) to upload / download parameters map
- serial communication RS485 card; to connect the control to a BMS network
- remote display terminal
- wire remote control

6.1 Control of the units, single / double compressor

The units are provided with a microprocessor card fully programmed by default for the control of a heat pump unit.

General information

The figure shows the terminal. It is provided with a 4 red digits with 7 segments with decimal point led, 18 LED and 4 buttons, to allow the programming of the control parameters (setpoint, differential bands, alarm thresholds) and the main operations to be carried out by the user.













6.2 Keypad functions







KEY	DESCRIPTION	SINGLE PUSH (PUSH / RELEASE)
	UP	- Increase value - Go to next label - Change Set-point
	DOWN	- Decrease value - Go to previous label - Change Set-point
	ESC	- Exit without saving - Go to previous level
	SET	- Confirm value / exit with setting saving - Go to next level - Go to status menu

LINKED FUNCTION	EXTENDED PUSH (MORE THAN 3S)	MENU / NOTES
/	- Enable Sanitary Hot Water function	
/	- Stand-by → ON	- Stand-by - Local ON/OFF
/	- Change mode	- Menu Mode
/	- Main display	- Menu Display

KEYS COMBINATION	LINKED FUNCTION	MENU / NOTES
	- Enable / Disable	- Time slots menu
	- Enter in "Program Menu"	- Program Menu

6 - Control (continued)

ICON / COLOUR	STEADY ICON	BLINKING ICON
 /Red	- Alarm ON	- Alarm QUIT
 /Green	- Mode: HEATING	- Antifreeze + Heat pump ON - Heating mode by remote
 /Green	- Mode: COOLING	- Cooling mode by remote
 /Green	- Mode: STAND-BY	- Stand-by mode by remote
 /Green	/	/
 /Green	- Configurable	- Configurable
 /Red	- Current HR - Time slots activ.	- HR setting - Time slots programming
 /Red	/	/
 /Red	/	/
 /Red	Not used	Not used
 /Red	Menu surf	/

LED N°*	DESCRIPTION	ICON
1	First capacity step	
2	Second capacity step	
3	Primary circuit pump	
4	Source circuit pump	
5	Electrical heater	
6	Sanitary hot water valve / pump	
7	Boiler	

6.3 Folder structure

Folder structure is composed of totally four menus

1. Main display → used to set what to display without acting on any key
 - Ai → analogue input (temperature, pressure)
 - rtC → room time clock
 - SetP → standard set-point
 - SetR → corrected set-point (according to climatic correction, etc.)
2. Operating mode → used to set operating mode
 - StbY → stand-by
 - HEAT → heating
 - COOL → cooling
 - AS → sanitary hot water
3. Status → used to show resources values
 - Ai (AIL / AIE / Air) → analogue inputs (main board / expansion board / remote terminal)
 - di (diL / diE) → digital inputs (main board / expansion board)
 - AO (AOL / AOE) → analogue outputs (main board / expansion board)
 - CL (HOUr / dAtE / YEAr) → clock
 - AL (Er00 → Er98) → alarms
 - SP → standard set-point
 - Sr → corrected set-point (according to climatic correction, etc.)
4. Program → define parameters, functions, password and to display alarm log

6 - Control (continued)

6.4 Menu structure

“Program” menu is composed of four folders in total

1. Parameters → change unit parameters
2. Functions → manual operations (switch ON / OFF, alarm quit, historic alarm delete, multi function key use)
3. Password → define visibility levels for parameters / folders
4. Alarm log → display alarm log

Parameter folder gives access to following sub-folders

- CL / CE / Cr / CF → configure device I/O (L → local; E → expansion; r → remote; F → serial)
 - analogue inputs (type of probe, range, differential, logic function)
 - digital inputs (logic function)
 - digital outputs (logic function)
 - analogue outputs (range)
 - serial configuration (communication parameters)
- TR → define thermoregulation parameters
 - set-point (max / min / hysteresis)
 - type (proportional / differential)
 - probe selection
- ST → define operating status
 - cooling only
 - heating only
 - cooling and heating
 - change-over
- CP → configure compressor parameters (type / number / timing)
- PI / PE → define primary circuit / source side circuit pump parameters / functions
 - operating mode (disable / always ON / ON if compressor ON)
 - digital / analogue control
 - anti-sticking
 - anti-freeze

- BR → control the parameters for an additional step for heating and for sanitary hot water integration (boiler)
 - operating mode (disable / differential → fixed or in function of outdoor air temperature)
 - set-point / hysteresis
- DS → define set-point offset (dynamic set-point) depending on
 - analogue input (0...1V, 0...5V, 0...10V, 4...20mA)
 - outdoor air temperature
 - room temperature
- AD → simulate an electronic inertial accumulator, acting on set-point and hysteresis (adaptive function), by confronting minimum / effective ON-OFF time
- AS → define sanitary hot water management parameters
 - operating mode (disable / sanitary hot water valve / resistance / pump)
 - set-point / hysteresis
 - anti-legionella function
- HP → define heat pump block management parameters
 - outdoor air temperature
 - thermoregulation temperature
 - digital input
- PL → define capacity limitation to protect the unit (high / low T, high / low P)
- TE → define time slots management (different operating daily profiles)
- AL → define alarms management (automatic / manual reset, by-pass time, sampling)

NOTE: Contact the After Sales service to get passwords

6 - Control (continued)

Climatic control kit

It is provided as standard to allow the unit managing the control of water temperature, according outdoor air temperature. Connect outdoor air temperature probe terminals to terminal AIE5 - GND on the electrical box (refer to Chapter "4 - Installation").

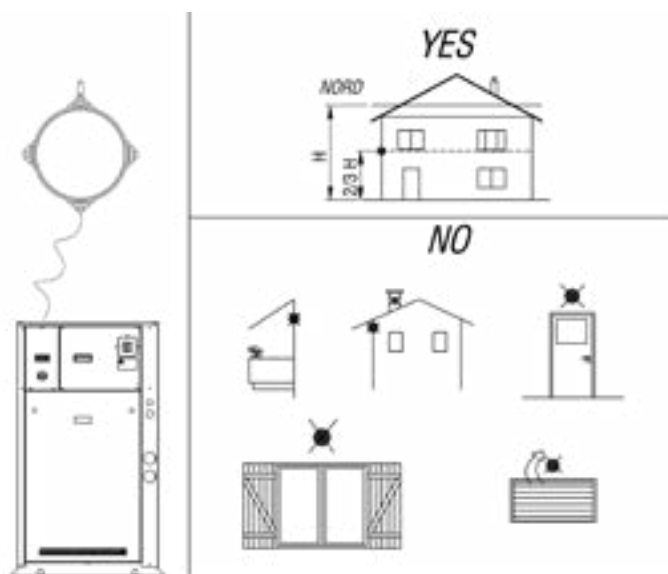

If OAS is not connected, error Er68 is shown (refer to chapter "6.5 Alarm list").

dS sub-folder is used to define set-point offset (dynamic set-point) depending on outdoor air temperature.

DESCRIPTION	U.M.	DEFAULT VALUE	NOTES
CE04 - Outdoor air temperature probe enabling		2	disabled → CE04=0 (alarm 68 disabled) NTC enabled → CE04=2
dS00 - Thermoregulator dynamic differential selection / outdoor air temperature	num	1	disabled → dS00=0 proportional → dS00=1 fixed step → dS00= 2
dS01 - COOL operation / Proportional band for dynamic differential	°C	- 10	
dS02 - HEAT operation / Proportional band for dynamic differential	°C	10	
dS03 - COOL operation / Maximum dynamic differential	°C	5	
dS04 - HEAT operation / Maximum dynamic differential	°C	5	
dS05 - COOL operation / Dynamic differential set-point	°C	30	
dS06 - HEAT operation / Dynamic differential set-point	°C	2	

WATER COMPENSATION RULE - HEATING MODE

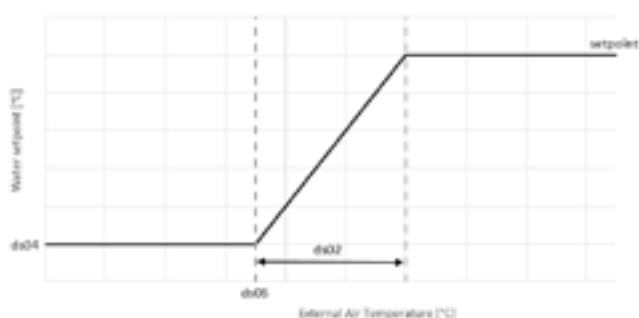

WATER COMPENSATION RULE - COOLING MODE

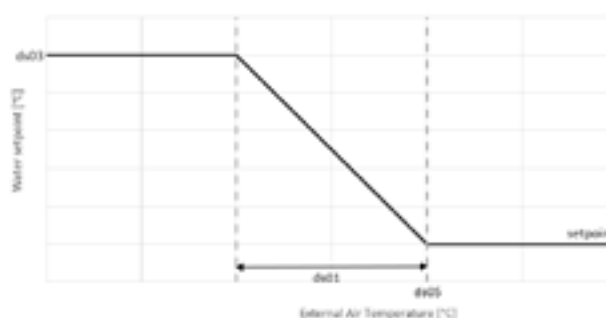

6 - Control (continued)

Pumps

The pumps (integrated inside the unit or externally installed) will be set by the unit in ON only if at least one compressor is being called by control: so the pumps will switch ON and after a settable delay, the first compressor will switch ON.

When unit reaches setpoint and all compressors stop, pumps will still be ON for a settable delay.

An anti-sticking function is also enabled by default to prevent any mechanical faults due to extended disuse.

The pump (integrated inside the unit or externally installed) on the indoor heat exchanger, will also run for a fixed period of time even when no compressors ON but unit ON to guarantee the correct reading of water temperatures and to ensure a more precise regulation (by default pumps will switch ON every 14 minutes for at least 1 minute).

DESCRIPTION	U.M.	DEFAULT VALUE	NOTES
Pi00 - Operating selection plant side pump	num	2	pump disabled → Pi00=0 continuous operation → Pi00=1 pump ON if compressor ON → Pi00= 2
Pi01 - Anti-sticking time (when pump is not active)	hours	8	
Pi03 - Minimum time for plant side pump switch-on	sec x 10	6	
Pi11 - Plant side pump activation if boiler is active	num	1	pump disabled → Pi11=0 pump ON if boiler ON → Pi11= 1
Pi20 - Delay between plant side pump ON and compressor ON	sec	60	
Pi21 - Delay between plant side pump OFF and compressor OFF	sec	60	
Pi22 - Period for plant side pump activation	min	14	
Pi50 - Probe selection for antifreeze protection through pump	num	0	antifreeze protection disabled → Pi50=0 RWT probe / plant side exchanger → Pi50=1 LWT probe / plant side exchanger → Pi50=2 OAT probe → Pi50=6
Pi51 - Water set point for pump activation / antifreeze protection	°C	8	
Pi52 - Pump antifreeze protection / thermoregulation hysteresis	°C	2	

DESCRIPTION	U.M.	DEFAULT VALUE	NOTES
PE00 – Source side pump operating selection	num	2	pump disabled → PE00=0 continuous operation → PE00=1 pump ON if compressor ON → PE00= 2
PE02 – Delay between source side pump ON and compressor ON	sec	60	
PE03 - Delay between source side pump OFF and compressor OFF	sec	60	
PE04 – Source side pump activation	num	1	anti-sticking OFF → PE04=0 anti-sticking ON → PE04= 1
PE05 - Anti-sticking time (when pump is not active)	hours	50	
PE06 - Minimum time for source side pump switch-on	sec x 10	6	

6 - Control (continued)

6.5 Alarm list

Code	Alarm unit description	CPS status	RESET auto/man	Internal circuit pump status	Internal circuit pump status	Sanitary valve / heater status
Er00	General alarm	OFF	A	OFF	OFF	OFF
Er01	High pressure circuit	OFF	M			
Er05	Low pressure circuit	OFF	A → M			
Er10	Thermal protection - compressor 1	OFF CPS 1	M			
Er11	Thermal protection - compressor 2	OFF CPS 2	M			
Er20	Plant side or source side flow switch	OFF	M	OFF (1)		OFF (1)
Er21	Thermal protection - plant side pump	OFF	A → M	OFF		
Er25	Source side flow switch	OFF	M		OFF (1)	
Er26	Thermal protection - source side pump	OFF	A → M		OFF	
Er30	Plant side antifreeze	OFF	A			
Er31	Source side antifreeze	OFF	A			
Er35	Water high temperature	OFF	A			
Er41	Thermal protection - source side pump (in case of condensing control option)	OFF	M		OFF	
Er45	Clock failure		A			
Er46	Clock to be set		A			
Er47	LAN communication error		A			
Er48	Legionella set-point not reached		A			
Er60	RWT probe plant side failure	OFF	A	OFF		
Er61	LWT probe plant side failure	OFF	A	OFF		
Er63	RWT probe plant side failure	OFF	A			
Er64	LWT probe plant side failure	OFF	A			
Er66	Sanitary hot water probe failure	OFF	A			
Er67	Visualization probe (T/P) failure		A			
Er68	Outdoor air temperature probe failure	OFF	A			
Er69	High pressure transducer failure	OFF	A			
Er73	Dynamic set-point failure		A			
Er80	Configuration error		A			OFF
Er81	Compressor maintenance		M			
Er85	Plant side pump maintenance		M			
Er86	Source side pump maintenance		M			
Er90	"Alarm history" number exceeded		M			

1. If alarm is manual type

7 - General Description

7.1 Introduction

The new range of water cooled chillers, includes 14 different capacities, fit for medium-sized residential, commercial and industrial applications.

All 14 sizes are available in three versions:

- **ECOi-W WQ C: cooling only unit**, requires a cooling tower or a dry cooler for heat dissipation purposes
- **ECOi-W WQ H: reversible heat pump unit**, the hot water's outlet temperature can reach 55°C (in heating mode), useful for sanitary water
- **ECOi-W WQ R: condenserless unit**, needs a remote condenser for heat dissipation purposes

7.2 General Specifications

These units are provided with cabinets made of oven-cured painted galvanised sheet panels. These panels are soundproof, thanks to deadening sleeve (optional), to ensure noiseless operation.

All units are factory-assembled and receive the necessary charge of refrigerant and oil (except for ECOi-W WQ R, which are shipped with a nitrogen charge) for compressors, so that they can be promptly installed. Every single unit is tested with water circulated through the heat exchangers, to check the performance of the refrigeration circuit.

7.3 Compressors

All compressors are of Scroll hermetic type, and the motor is cooled by the suction gas; they are also provided with an oil heater from size 60. 20 to 45 models have a compressor, while the 50 to 190 models are equipped with two compressors in tandem.

All compressors are mounted on rubber shock absorbers, to minimise the sound level and the vibration transmission.

7.4 Refrigeration circuits

The refrigeration circuit is provided with a thermostatic expansion valve, dehydrating cartridge filter, sight glass with a colour-change humidity indicator, and HP and SP pressure switches.

ECOi-W WQ H units also feature a 4-way valve and check valves to always run the expansion valve and filter in the same way.

ECOi-W WQ R units also feature a solenoid valve and a liquid receiver.

7.5 Evaporator

The direct-expansion evaporator consists of a welded stainless steel plate-type heat exchanger.

The evaporator's standard accessories include a closed-cell polyurethane sleeve, and a water pressure differential switch.

7.6 Condenser (except for ECOi-W WQ R)

The water-cooled condenser consists of a welded stainless steel plate-type heat exchanger.

The condenser's standard accessories include a closed-cell polyurethane sleeve, and a water pressure differential switch.

7.7 Switchboard

All the electrical devices required to operate the unit are housed inside a separate compartment, which can be accessed from the front side of the appliance, via a panel secured by lock screws.

The switchboard, manufactured to CE standards, includes the master disconnect with external handle locked in the open position, contactors and thermal protections, fuses for the control circuit, phase sequence controller, water sensor, electronic controller, HP and LP pressure switch, timer (to prevent frequent starts), ON/OFF switch and terminal board.

7 - General Description (continued)

ECOi-W WQ 20-45 C Refrigeration System

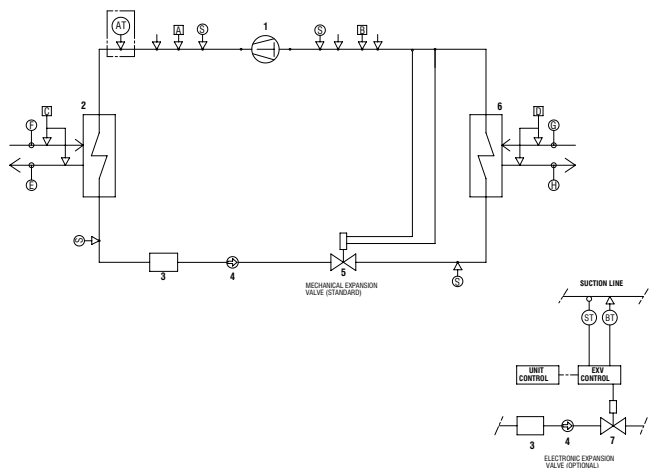

COMPONENTS	
1	Compressor
2	Condenser
3	Filter drier
4	Sight glass
5	Mechanical expansion valve
6	Evaporator
7	Electronic expansion valve

SAFETY / CONTROL DEVICES	
A	High pressure switch (42 Bar)
B	Low pressure switch (2 Bar)
AT	High pressure transducer (optional)
BT	Low pressure transducer
ST	Suction temperature probe
S	5/16" Schrader connection (service only)
C	Water differential pressure switch
F	Inlet water temperature sensor
E	Outlet water temperature sensor
D	Water differential pressure switch
G	Inlet water temperature sensor
H	Outlet water temperature sensor
↓	Pipe connection with Schrader valve

ECOi-W WQ 20-45 H Refrigeration System

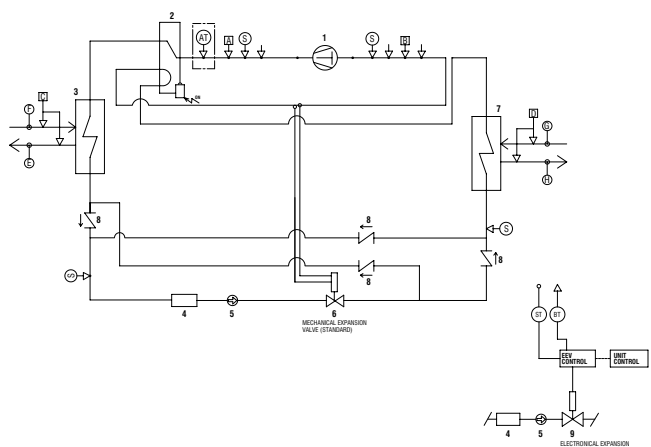

COMPONENTS	
1	Compressor
2	4 way valve
3	Condenser
4	Filter drier
5	Sight glass
6	Mechanical expansion valve
7	Evaporator
8	Check valve
9	Electronic expansion valve

SAFETY / CONTROL DEVICES	
A	High pressure switch (42 Bar)
B	Low pressure switch (2 Bar)
AT	High pressure transducer (optional)
BT	Low pressure transducer
S	5/16" Schrader connection (service only)
C	Water differential pressure switch
F	Inlet water temperature sensor
E	Outlet water temperature sensor
D	Water differential pressure switch
G	Inlet water temperature sensor
H	Outlet water temperature sensor
↓	Pipe connection with Schrader valve

ECOi-W WQ 20-45 R Refrigeration System

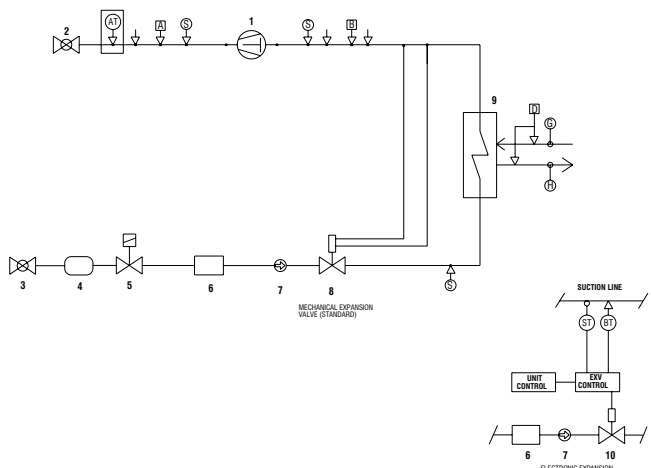

COMPONENTS	
1	Compressor
2	Globe valve
3	Globe valve
4	Liquid receiver
5	Solenoid valve
6	Filter drier
7	Sight glass
8	Mechanical expansion valve
9	Evaporator
10	Electronic expansion valve

SAFETY / CONTROL DEVICES	
A	High pressure switch (42 Bar)
B	Low pressure switch (2 Bar)
AT	High pressure transducer (optional)
BT	Low pressure transducer
ST	Suction temperature probe
S	5/16" Schrader connection (service only)
D	Water differential pressure switch
G	Inlet water temperature sensor
H	Outlet water temperature sensor
↓	Pipe connection with Schrader valve

7 - General Description (continued)

ECOi-W WQ 50-190 C Refrigeration System

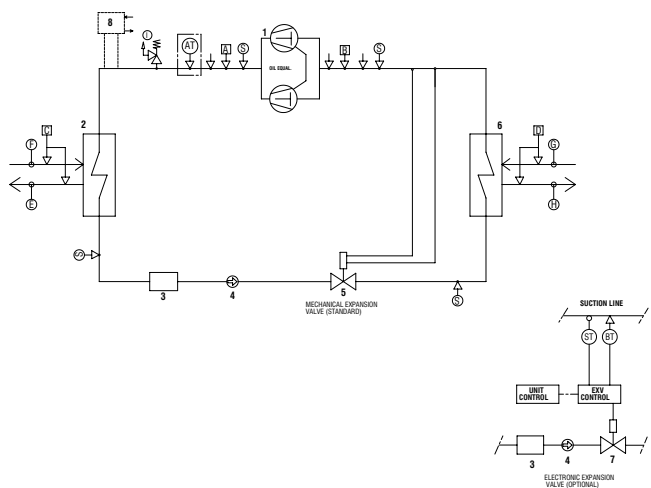

COMPONENTS	
1	Compressor
2	Condenser
3	Filter drier
4	Sight glass
5	Mechanical expansion valve
6	Evaporator
7	Electronic expansion valve
8	Desuperheater

SAFETY / CONTROL DEVICES	
A	High pressure switch (40.5 Bar)
B	Low pressure switch (2 Bar)
BT	Low pressure transducer
AT	High pressure transducer (optional)
S	5/16" Schrader connection (service only)
C	Water differential pressure switch
F	Inlet water temperature sensor
E	Outlet water temperature sensor
D	Water differential pressure switch
G	Inlet water temperature sensor
H	Outlet water temperature sensor
I	PED pressure valve (45 Bar)
↓	Pipe connection with Schrader valve

ECOi-W WQ 50-190 H Refrigeration System

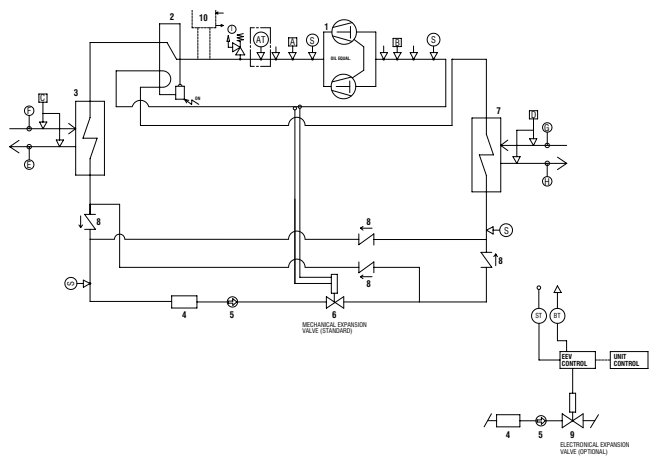

COMPONENTS	
1	Compressor
2	4 way valve
3	Condenser
4	Filter drier
5	Sight glass
6	Mechanical expansion valve
7	Evaporator
8	Check valve
9	Electronic expansion valve
10	Desuperheater

SAFETY / CONTROL DEVICES	
A	High pressure switch (40.5 Bar)
B	Low pressure switch (2 Bar)
BT	Low pressure transducer
AT	High pressure transducer (optional)
S	5/16" Schrader connection (service only)
C	Water differential pressure switch
F	Inlet water temperature sensor
E	Outlet water temperature sensor
D	Water differential pressure switch
G	Inlet water temperature sensor
H	Outlet water temperature sensor
I	PED pressure relief valve (45 Bar)
↓	Pipe connection with Schrader valve

ECOi-W WQ 50-190 R Refrigeration System

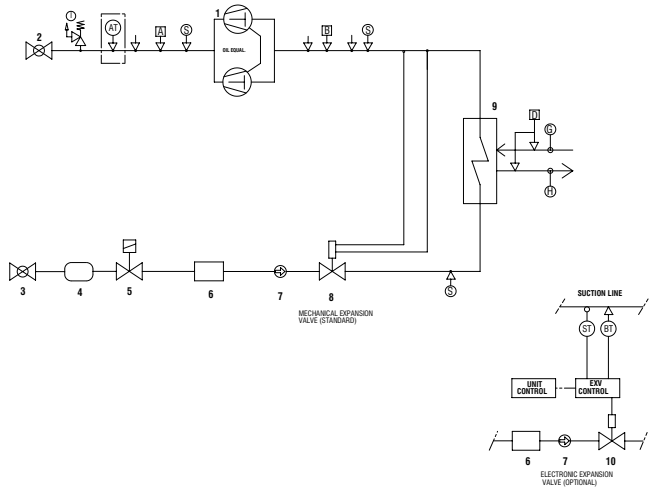

COMPONENTS	
1	Compressor
2	Globe valve
3	Globe valve
4	Liquid receiver
5	Solenoid valve
6	Filter drier
7	Sight glass
8	Mechanical expansion valve
9	Evaporator
10	Electronic expansion valve

SAFETY / CONTROL DEVICES	
A	High pressure switch (40.5 Bar)
B	Low pressure switch (2 Bar)
AT	High pressure transducer (optional)
BT	Low pressure transducer
ST	Suction temperature probe
S	5/16" Schrader connection (service only)
D	Water differential pressure switch
G	Inlet water temperature sensor
H	Outlet water temperature sensor
I	PED pressure valve (45 Bar)
↓	Pipe connection with Schrader valve

7 - General Description (continued)

7.8 Accessories

Water Filter

1-1/2" filter (20-45 units) and 2-1/2" filter (50-190 units) is supplied loose and **MUST** be mounted by the installer. (both evaporator and condenser side)

Anti-Vibration Kit

Anti-vibration kit made of special rubber pads is provided together with the unit.

Water Differential Pressure Switch

Water differential pressure switch is mounted as standard in the unit.

Flow switch kit

Flow switch kit is available as an accessory. It is supplied loose and **MUST** be mounted by the Installer. Connect terminals of the evaporator flow switch with terminals 04-05A of the electrical box.

Connect terminals of the condenser flow switch with terminals 05A-05 or 6-7, depending on the application, (see note below) of the electrical box.

The software managing the water cooled range is featuring, by default, a logic function by-passing any water flow alarm when occurring on the source heat exchanger during the cooling operation of the unit. This is because many water-cooled applications are working with modulation of the water flow due to the cold temperature of the media (city network in example), and this could generate fake water flow alarm conditions. In case the unit is heat pump type, reversing the cycle on the refrigerant side, the alarm comes enabled because the heat exchanger changes its role (from condenser to evaporator) and operation with poor water flow rate could generate a dangerous condition (heat exchanger freezing for example).

For those specific applications where it is mandatory to protect the source heat exchanger during the cooling operation, it is possible to connect an external water flow protection device (water flow switch / water pressure switch) to the connection 05A-05 (user terminal QG - Y1). This additional protection, mounted in series with the plant side heat exchanger protection, would generate alarm condition in case of operation with poor water flow rate.



Pump(s) Kit

Min. 100 kPa head pressure pump be mounted as an option both evaporator and condenser side (sizes 20 to 45).

A single or double 100-150 [kPa] head pressure pump can be mounted as an option (1/2P-SP) both evaporator and condenser side (sizes 50 to 190).

A single or double 200-250 [kPa] head pressure pump can be mounted as an option (1/2P-HP) both evaporator and condenser side (sizes 50 to 190).

Phase Monitor Kit

It is assembled on the unit as a standard.

Airfreight Packaging

Complete wooden package for units without refrigerant and with nitrogen precharge. The unit is shipped without refrigerant. The customer has to fill the unit through the appropriate connection.

Remote On/Off Kit

It enables the operator to power on the unit when it is in standby mode, to display alarms and to switch between cooling and heating. The kit includes a 3 metre long cable for installation on the wall.

Sequencer kit - 4 units

It can easily pilot up to 4 units fitted in parallel, maximum 50 metres apart.

Gauge kit

Gauge kit is available as an option.

Domestic hot water kit

It is provided as an accessory to allow the unit managing the control of a 3 ways valve, in order to switch water flow from plant to boiler.

A water probe as to be installed remotely inside the boiler in order to read sanitary hot water temperature.

Connect water probe terminals to terminal AI5 - GND on the electrical box (refer to Chapter "4 - Installation").

Connect 3 ways valve terminals to terminal 93 - 8 of the electrical box (refer to Chapter "4 - Installation").

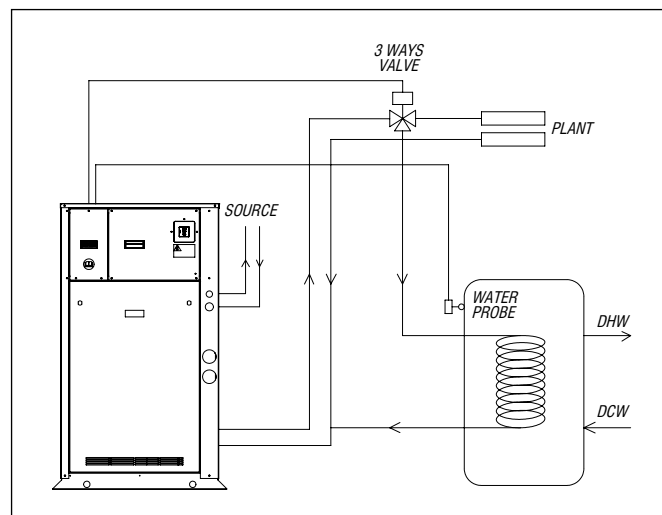

Domestic hot water integration kit

It is provided as an option/accessory to allow the unit managing the control of a relays for an electrical heater, in order to integrate the production of sanitary hot water.

Connect the relays to terminal DO5-12V of the electrical box (refer to Chapter "4 - Installation").

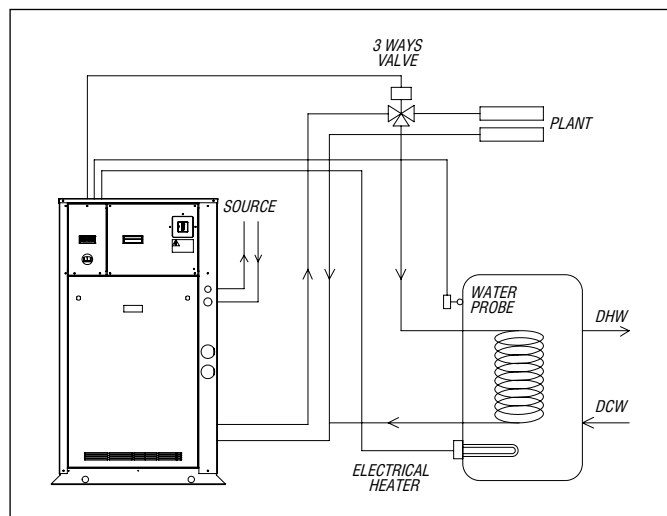

Additional heating device kit

It is provided as an option / accessory to allow the unit managing the control of an additional heating device (a boiler for example), to integrate the production of hot water.

Connect the additional heating device to terminal 33-8 of the electrical box (refer to Chapter "4 - Installation").

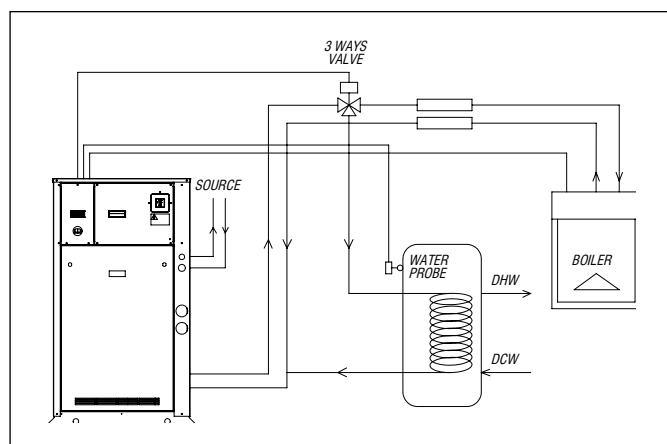

Condensing control kit

It is provided as an option / accessory to allow the unit managing the control of condensation, in case very cold water (from a well for example) is entering the condenser. A 0-10V signal (terminal 2-3 of the electrical box / refer to Chapter "4 - Installation") is available to manage a variable flow device (for example 2/3 ways modulating valve, inverter pump).

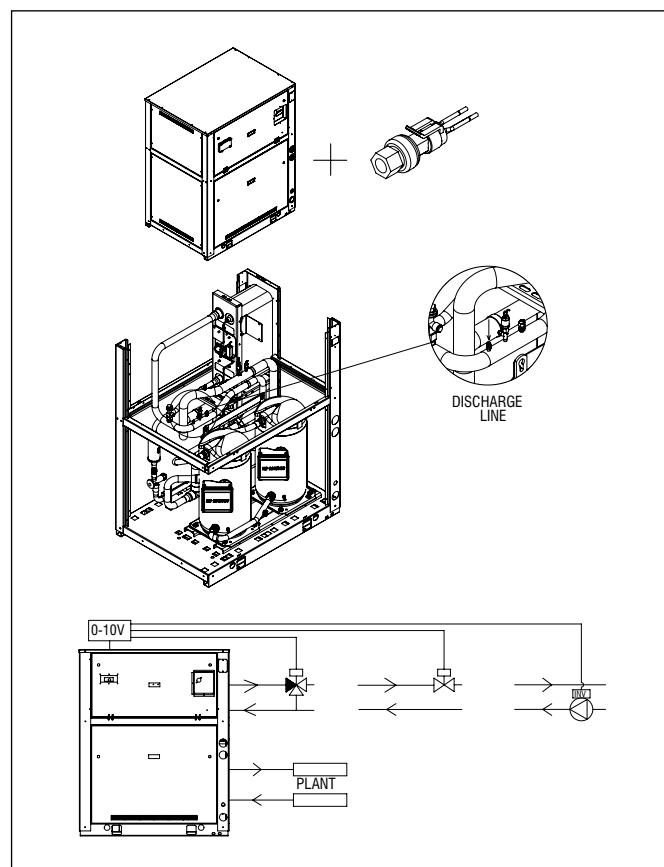

7 - General Description (continued)

Antivibrating supports (AVM)

Isolating spring supports, equipped with bolts for fastening to the base. They are supplied separately from the unit and must be mounted on site by the Installer, at the Customer's expense.

Remote wall terminal

Provides access to the unit through a remote terminal, up to a maximum distance of 100 meters.

RS-485 protocol Modbus

A communication interface makes it possible to control and manage the unit from a building management or similar system, with RS485 connection.

It is possible to remotely control and manage the system by connecting the control into the management plant of the building.

Pressostatic Valve Kit (20-45 units)

This item is available only for cooling only units. The pressostatic valve, controlled by condensing pressure, regulates the water flow to maintain the condensing temperature at the desired value (the condensing temperature of +40 °C is recommended).

8 - Technical Data

For Performance data and Information requirements for heat pump space heaters see dedicated documents and manuals.

8.1 Pressure drops

PRESSURE DROP IN THE EVAPORATOR 20 to 45							
		20	25	30	35	40	45
K	kPa/(l/s) ²	17,0	16,5	15,9	15,6	11,4	7,97
Minimum flow rate	l/s	0,62	0,78	0,90	1,02	1,15	1,37
Nominal flow rate	l/s	1,00	1,25	1,45	1,63	1,83	2,19
Maximum flow rate	l/s	1,66	2,08	2,41	2,72	3,06	3,65
Minimum pressure drop	kPa	6,6	10,0	13,0	16,3	15,0	14,9
Nominal pressure drop	kPa	17,0	25,6	33,4	41,7	38,3	38,2
Maximum pressure drop	kPa	47,2	71,2	92,8	115,8	106,4	106,0

$$\Delta P = K \cdot Q^2$$

PRESSURE DROP IN THE CONDENSER - 20 to 45							
		20	25	30	35	40	45
K	kPa/(l/s) ²	9,32	8,94	17,70	8,59	8,48	3,60
Minimum flow rate	l/s	0,76	0,94	1,10	1,24	1,39	1,66
Nominal flow rate	l/s	1,21	1,51	1,76	1,98	2,23	2,66
Maximum flow rate	l/s	2,02	2,52	2,93	3,31	3,72	4,43
Minimum pressure drop	kPa	5,4	8,0	21,4	13,2	16,5	9,9
Nominal pressure drop	kPa	13,7	20,4	54,8	33,8	42,1	25,4
Maximum pressure drop	kPa	38,1	56,7	152,1	93,9	117,0	70,6

$$\Delta P = K \cdot Q^2$$

PRESSURE DROP IN THE EVAPORATOR - 50 to 190									
		50	60	75	90	120	150	170	190
K	kPa/(l/s) ²	4,20	2,35	1,56	1,09	0,66	0,46	0,37	0,29
Minimum flow rate	l/s	1,50	1,77	2,28	2,66	3,44	4,32	4,97	5,56
Nominal flow rate	l/s	2,40	2,83	3,65	4,25	5,51	6,92	7,95	8,89
Maximum flow rate	l/s	4,00	4,71	6,08	7,09	9,18	11,5	13,2	14,8
Minimum pressure drop	kPa	9,43	7,34	8,10	7,70	7,83	8,52	9,07	9,08
Nominal pressure drop	kPa	24,1	18,8	20,7	19,7	20,0	21,8	23,2	23,3
Maximum pressure drop	kPa	67,0	52,2	57,6	54,8	55,7	60,6	64,5	64,6

$$\Delta P = K \cdot Q^2$$

PRESSURE DROP IN THE CONDENSER - 50 to 190									
		50	60	75	90	120	150	170	190
K	kPa/(l/s) ²	4,20	2,35	1,56	1,09	0,66	0,46	0,37	0,29
Minimum flow rate	l/s	1,84	2,16	2,78	3,26	4,22	5,28	6,06	6,81
Nominal flow rate	l/s	2,94	3,46	4,45	5,22	6,75	8,45	9,70	10,9
Maximum flow rate	l/s	4,91	5,77	7,41	8,70	11,3	14,1	16,2	18,2
Minimum pressure drop	kPa	14,2	11,0	12,0	11,6	11,8	12,7	13,5	13,6
Nominal pressure drop	kPa	36,3	28,2	30,8	29,7	30,1	32,6	34,6	34,9
Maximum pressure drop	kPa	101,0	78,2	85,6	82,6	83,6	90,5	96,2	96,9

$$\Delta P = K \cdot Q^2$$

PRESSURE DROP IN THE DESUPERHEATER - 50 to 190									
		50	60	75	90	120	150	170	190
K	kPa/(l/s) ²	29,9	9,86	6,79	5,64	3,47	3,28	2,96	1,96
Minimum flow rate	l/s	0,33	0,42	0,54	0,63	0,75	1,02	1,17	1,22
Nominal flow rate	l/s	0,53	0,68	0,86	1,00	1,20	1,63	1,87	1,96
Maximum flow rate	l/s	0,88	1,13	1,44	1,67	2,01	2,72	3,11	3,26
Minimum pressure drop	kPa	3,24	1,77	1,98	2,22	1,97	3,41	4,03	2,93
Nominal pressure drop	kPa	8,28	4,52	5,06	5,68	5,03	8,72	10,3	7,49
Maximum pressure drop	kPa	23,0	12,6	14,0	15,8	14,0	24,2	28,7	20,8

$$\Delta P = K \cdot Q^2$$

8 - Technical Data (continued)

8.2 Technical data

ECOi-W WQ 20-45 C		20	25	30	35	40	45
Number of refrigerant circuits		1	1	1	1	1	1
Part load steps %		0-100	0-100	0-100	0-100	0-100	0-100
Power supply V/ph/Hz		400V/3/50Hz					
Startup type		Direct	Direct	Direct	Direct	Direct	Direct
REFRIGERANT							
Type / GWP		R410A / 2088					
Charge ¹	kg	2,8	2,8	2,8	2,8	2,9	5,2
	tCO ₂ eq	5,8	5,8	5,8	5,8	6,1	10,9
COMPRESSORS							
Number		1	1	1	1	1	1
Type		Scroll					
EVAPORATOR							
Number		1	1	1	1	1	1
Type		Plate					
Water flow rate l/s		1,02	1,26	1,50	1,68	1,89	2,24
Water pressure drop kPa		17,7	26,2	35,6	43,9	40,5	39,7
WATER CONNECTIONS							
Type		Victaulic					
Inlet diameter inch		1"1/2	1"1/2	1"1/2	1"1/2	1"1/2	1"1/2
Outlet diameter inch		1"1/2	1"1/2	1"1/2	1"1/2	1"1/2	1"1/2
CONDENSER							
Number		1	1	1	1	1	1
Type		Plate					
Water flow rate l/s		1,23	1,52	1,80	2,02	2,28	2,70
Water pressure drop kPa		14,5	21,4	57,4	35,8	44,8	26,5
WATER CONNECTIONS							
Type		Victaulic					
Inlet diameter inch		1"1/2	1"1/2	1"1/2	1"1/2	1"1/2	1"1/2
Outlet diameter inch		1"1/2	1"1/2	1"1/2	1"1/2	1"1/2	1"1/2
WEIGHT							
Shipping weight kg		156	176	174	179	185	203
Operating weight kg		162	182	179	185	191	214
DIMENSIONS							
Length mm		821	821	821	821	821	821
Width mm		455	455	455	455	455	455
Height mm		1350	1350	1350	1350	1350	1350

¹ The refrigerant values are indicative values for standard units. The actual data are indicated on the unit label.

8 - Technical Data (continued)

ECOi-W WQ 20-45 H		20	25	30	35	40	45
Number of refrigerant circuits		1	1	1	1	1	1
Part load steps %		0-100	0-100	0-100	0-100	0-100	0-100
Power supply V/ph/Hz		400V/3/50Hz					
Startup type		Direct	Direct	Direct	Direct	Direct	Direct
REFRIGERANT							
Type / GWP		R410A / 2088					
Charge ¹	kg	3,0	3,1	3,1	3,4	3,2	5,5
	tCO ₂ eq	6,3	6,5	6,5	7,1	6,7	11,5
COMPRESSORS							
Number		1	1	1	1	1	1
Type		Scroll					
INTERNAL HEAT EXCHANGER							
Number		1	1	1	1	1	1
Type		Plate					
SUMMER OPERATION							
Water flow rate l/s		1,00	1,25	1,45	1,63	1,83	2,19
Water pressure drop kPa		17,0	25,6	33,4	41,7	38,3	38,2
WINTER OPERATION							
Water flow rate l/s		1,44	1,75	2,03	2,33	2,60	3,11
Water pressure drop kPa		19,2	27,4	73,2	46,7	57,1	34,7
WATER CONNECTIONS							
Type		Victaulic					
Inlet diameter inch		1"1/2	1"1/2	1"1/2	1"1/2	1"1/2	1"1/2
Outlet diameter inch		1"1/2	1"1/2	1"1/2	1"1/2	1"1/2	1"1/2
EXTERNAL HEAT EXCHANGER							
Number		1	1	1	1	1	1
Type		Plate					
SUMMER OPERATION							
Water flow rate l/s		1,21	1,51	1,76	1,98	2,23	2,66
Water pressure drop kPa		13,7	20,4	54,8	33,8	42,1	25,4
WINTER OPERATION							
Water flow rate l/s		1,44	1,75	2,03	2,33	2,60	3,11
Water pressure drop kPa		19,2	27,4	73,2	46,7	57,1	34,7
WATER CONNECTIONS							
Type		Victaulic					
Inlet diameter inch		1"1/2	1"1/2	1"1/2	1"1/2	1"1/2	1"1/2
Outlet diameter inch		1"1/2	1"1/2	1"1/2	1"1/2	1"1/2	1"1/2
WEIGHT							
Shipping weight kg		159	181	179	184	190	208
Operating weight kg		165	187	184	190	195	219
DIMENSIONS							
Length mm		821	821	821	821	821	821
Width mm		455	455	455	455	455	455
Height mm		1350	1350	1350	1350	1350	1350

¹ The refrigerant values are indicative values for standard units. The actual data are indicated on the unit label.

8 - Technical Data (continued)

ECOi-W WQ 20-45 R		20	25	30	35	40	45
Number of refrigerant circuits		1	1	1	1	1	1
Part load steps %		0-100	0-100	0-100	0-100	0-100	0-100
Power supply V/ph/Hz		400V/3/50Hz					
Startup type		Direct	Direct	Direct	Direct	Direct	Direct
REFRIGERANT							
Type / GWP		R410A / 2088					
Charge ¹	kg	2,8	2,8	2,8	2,8	2,9	5,2
	tCO ₂ eq	5,8	5,8	5,8	5,8	6,1	10,9
COMPRESSORS							
Number		1	1	1	1	1	1
Type		Scroll					
EVAPORATOR							
Number		1	1	1	1	1	1
Type		Plate					
Water flow rate l/s		1,00	1,24	1,50	1,66	1,88	2,21
Water pressure drop kPa		17,1	25,4	35,6	43,7	34,3	38,9
WATER CONNECTIONS							
Type		Victaulic					
Inlet diameter inch		1"1/2	1"1/2	1"1/2	1"1/2	1"1/2	1"1/2
Outlet diameter inch		1"1/2	1"1/2	1"1/2	1"1/2	1"1/2	1"1/2
REMOTE CONDENSER REFRIGERANT CONNECTIONS							
Type		To be brazed					
Inlet diameter inch		5/8"	5/8"	5/8"	5/8"	5/8"	5/8"
Outlet diameter inch		5/8"	7/8"	7/8"	7/8"	7/8"	7/8"
WEIGHT							
Shipping weight kg		142	161	163	163	169	168
Operating weight kg		144	164	166	166	172	172
DIMENSIONS							
Length mm		821	821	821	821	821	821
Width mm		455	455	455	455	455	455
Height mm		1350	1350	1350	1350	1350	1350

¹ The value is representing the contribution to the global refrigerant charge given by the standard unit only. Contribution of connection piping and remote condenser is not included here.

8 - Technical Data (continued)

ECOi-W WQ 50-190 C		50	60	75	90	120	150	170	190
Number of refrigerant circuits		1	1	1	1	1	1	1	1
Part load steps	%	0-50-100	0-50-100	0-50-100	0-50-100	0-50-100	0-50-100	0-50-100	0-50-100
Power supply	V/ph/Hz	400V/3/50Hz							
Startup type		Direct	Direct	Direct	Direct	Direct	Direct	Direct	Direct
REFRIGERANT									
Type / GWP		R410A / 2088							
Charge ¹	kg	4,4	5,7	6,9	8,3	11,3	13,8	15,5	18,1
	tCO ₂ eq	9,2	11,9	14,4	17,3	23,6	28,8	32,4	37,8
COMPRESSORS									
Number		2	2	2	2	2	2	2	2
Type		Scroll							
Crankcase heater	W	-	90+90	90+90	90+90	120+120	150+150	150+150	150+150
EVAPORATOR									
Number		1	1	1	1	1	1	1	1
Type		Plate							
Water flow rate	l/s	2,44	2,93	3,71	4,37	5,68	7,05	8,15	9,24
Water pressure drop	kPa	25,1	20,2	21,4	20,7	21,2	22,6	24,4	25,0
WATER CONNECTIONS									
Type		Victaulic							
Inlet diameter	inch	2"1/2	2"1/2	2"1/2	2"1/2	2"1/2	2"1/2	2"1/2	2"1/2
Outlet diameter	inch	2"1/2	2"1/2	2"1/2	2"1/2	2"1/2	2"1/2	2"1/2	2"1/2
CONDENSER									
Number		1	1	1	1	1	1	1	1
Type		Plate							
Water flow rate	l/s	2,98	3,55	4,50	5,33	6,90	8,57	9,89	11,21
Water pressure drop	kPa	35,0	27,0	29,0	28,0	29,0	32,0	34,0	35,0
WATER CONNECTIONS									
Type		Victaulic							
Inlet diameter	inch	2"1/2	2"1/2	2"1/2	2"1/2	2"1/2	2"1/2	2"1/2	2"1/2
Outlet diameter	inch	2"1/2	2"1/2	2"1/2	2"1/2	2"1/2	2"1/2	2"1/2	2"1/2
DESUPERHEATER									
Number		1	1	1	1	1	1	1	1
Type		Plate							
Water flow rate	l/s	0,53	0,68	0,86	1,00	1,20	1,63	1,87	1,96
Water pressure drop	kPa	8,3	4,5	5,1	5,7	5,0	8,7	10,3	7,5
WATER CONNECTIONS									
Type		MGT							
Inlet diameter	inch	1"	1"	1"	1"	1"	1"	1"	1"
Outlet diameter	inch	1"	1"	1"	1"	1"	1"	1"	1"
WEIGHT									
Shipping weight	kg	345	361	380	397	578	642	673	713
Operating weight	kg	352	371	392	411	597	666	701	745
DIMENSIONS									
Length	mm	1210	1210	1210	1210	1210	1210	1210	1210
Width	mm	850	850	850	850	850	850	850	850
Height	mm	1500	1500	1500	1500	1500	1500	1500	1500

¹ The refrigerant values are indicative values for standard units. The actual data are indicated on the unit label.

8 - Technical Data (continued)

ECOi-W WQ 50-190 H		50	60	75	90	120	150	170	190
Number of refrigerant circuits		1	1	1	1	1	1	1	1
Part load steps	%	0-50-100	0-50-100	0-50-100	0-50-100	0-50-100	0-50-100	0-50-100	0-50-100
Power supply	V/ph/Hz	400V/3/50Hz							
Startup type		Direct	Direct	Direct	Direct	Direct	Direct	Direct	Direct
REFRIGERANT									
Type / GWP		R410A / 2088							
Charge ¹	kg	6,0	6,0	7,2	8,6	11,8	14,3	16,0	18,6
	tCO ₂ eq	12,5	12,5	15,0	18,0	24,6	29,9	33,4	38,8
COMPRESSORS									
Number		2	2	2	2	2	2	2	2
Type		Scroll							
Crankcase heater	W	-	90+90	90+90	90+90	120+120	150+150	150+150	150+150
INTERNAL HEAT EXCHANGER									
Number		1	1	1	1	1	1	1	1
Type		Plate							
SUMMER OPERATION									
Water flow rate	l/s	2,40	2,83	3,65	4,25	5,51	6,92	7,95	8,89
Water pressure drop	kPa	24,1	18,8	20,7	19,7	20,0	21,8	23,2	23,3
WINTER OPERATION									
Water flow rate	l/s	2,74	3,24	4,11	4,86	6,29	7,82	9,05	10,1
Water pressure drop	kPa	31,6	24,7	26,3	25,8	26,1	27,9	30,2	30,1
WATER CONNECTIONS									
Type		Victaulic							
Inlet diameter	inch	2"1/2	2"1/2	2"1/2	2"1/2	2"1/2	2"1/2	2"1/2	2"1/2
Outlet diameter	inch	2"1/2	2"1/2	2"1/2	2"1/2	2"1/2	2"1/2	2"1/2	2"1/2
EXTERNAL HEAT EXCHANGER									
Number		1	1	1	1	1	1	1	1
Type		Plate							
SUMMER OPERATION									
Water flow rate	l/s	2,94	3,46	4,45	5,22	6,75	8,45	9,70	10,89
Water pressure drop	kPa	37,3	28,7	31,2	29,2	29,5	32,1	34,8	34,1
WINTER OPERATION									
Water flow rate	l/s	3,48	4,09	5,23	6,17	7,99	9,97	11,52	12,9
Water pressure drop	kPa	53,4	40,7	43,6	40,2	40,5	44,2	49,4	46,5
DESUPERHEATER									
Number		1	1	1	1	1	1	1	1
Type		Plate							
Water flow rate	l/s	0,53	0,68	0,86	1,00	1,20	1,63	1,87	1,96
Water pressure drop	kPa	8,3	4,5	5,1	5,7	5,0	8,7	10,3	7,5
WATER CONNECTIONS									
Type		MGT							
Inlet diameter	inch	1"	1"	1"	1"	1"	1"	1"	1"
Outlet diameter	inch	1"	1"	1"	1"	1"	1"	1"	1"
WEIGHT									
Shipping weight	kg	353	369	391	408	591	659	691	730
Operating weight	kg	360	379	403	422	610	683	718	762
DIMENSIONS									
Length	mm	1210	1210	1210	1210	1210	1210	1210	1210
Width	mm	850	850	850	850	850	850	850	850
Height	mm	1500	1500	1500	1500	1500	1500	1500	1500

¹ The refrigerant values are indicative values for standard units. The actual data are indicated on the unit label.

8 - Technical Data (continued)



ECOi-W WQ 50-190 R		50	60	75	90	120	150	170	190
Number of refrigerant circuits		1	1	1	1	1	1	1	1
Part load steps %		0-50-100	0-50-100	0-50-100	0-50-100	0-50-100	0-50-100	0-50-100	0-50-100
Power supply V/ph/Hz		400V/3/50Hz							
Startup type		Direct	Direct	Direct	Direct	Direct	Direct	Direct	Direct
REFRIGERANT									
Type / GWP		R410A / 2088							
Charge ¹	kg	4,4	5,7	6,9	8,3	11,3	13,8	15,5	18,1
	tCO ₂ eq	9,2	11,9	14,4	17,3	23,6	28,8	32,4	37,8
COMPRESSORS									
Number		1	1	1	1	1	1	1	1
Type		Scroll							
Crankcase heater W		-	90+90	90+90	90+90	120+120	150+150	150+150	150+150
EVAPORATOR									
Number		1	1	1	1	1	1	1	1
Type		Plate							
Water flow rate l/s		2,45	2,95	3,72	4,37	5,67	7,05	8,09	9,23
Water pressure drop kPa		25,2	20,5	21,5	20,7	21,2	22,6	24,1	24,9
WATER CONNECTIONS									
Type		Victaulic							
Inlet diameter inch		2"1/2	2"1/2	2"1/2	2"1/2	2"1/2	2"1/2	2"1/2	2"1/2
Outlet diameter inch		2"1/2	2"1/2	2"1/2	2"1/2	2"1/2	2"1/2	2"1/2	2"1/2
REMOTE CONDENSER REFRIGERANT CONNECTIONS									
Type		To be brazed							
Inlet diameter inch		5/8"	5/8"	7/8"	7/8"	7/8"	7/8"	1 1/8"	1 1/8"
Outlet diameter inch		7/8"	7/8"	1 1/8"	1 1/8"	1 3/8"	1 5/8"	1 5/8"	1 5/8"
WEIGHT									
Shipping weight kg		329	339	359	369	548	600	629	658
Operating weight kg		332	344	365	376	558	612	643	674
DIMENSIONS									
Length mm		1210	1210	1210	1210	1210	1210	1210	1210
Width mm		850	850	850	850	850	850	850	850
Height mm		1500	1500	1500	1500	1500	1500	1500	1500

¹ The value is representing the contribution to the global refrigerant charge given by the standard unit only. Contribution of connection piping and remote condenser is not included here.

8 - Technical Data (continued)

8.3 Refrigerant circuit specifications

Refrigerant charge

	<p>The system contains fluorinated greenhouse gases under the Kyoto Protocol. The type and quality of refrigerant per circuit are specified in the product label.</p> <p>The installer and end user must obtain information on local environmental regulations for installation, use and disposal of the equipment, in particular with regard to the recovery of environmentally-hazardous substances (refrigerant, oil, antifreeze fluids, etc.). Any refrigerant must not be released into the environment. Refrigerants must be managed by qualified personnel.</p>
	<p>The units use fluid HFC R410A, belonging to group 2 as defined in Directive 2014/68/EU.</p>

5. A document containing a description of all the operations carried out on the refrigeration circuit must be drawn up and retained.

	<p>Failure to comply with any of these obligations constitutes a violation, which may result in financial penalties.</p> <p>In case of problems, it is also mandatory to prove compliance of the equipment with the fluorinated gas regulation to the insurance company.</p>
---	--

Calculation of quantity of greenhouse gases

Quantity of greenhouse gases (kg of CO₂) = Quantity of gas (kg) x gas GWP

Quantity of greenhouse gases expressed in weight (kg) and CO₂ equivalent

Quantity of gas: quantity of gas contained in the machine in kg (see label)

GWP (Global Warming Potential) of the gas contained in the machine (see label)

→ GWP for R410A = 2088

Regulation on fluorinated gases

Regulation (EU) no. 517/2014 on fluorinated greenhouse gases requires users of refrigeration equipment to comply with the following 5 obligations:

1. Installation, maintenance, service and leak test operations must be carried out by qualified personnel.
2. Fluorinated gases must be recovered during maintenance and service operations, as well as at the end of life of the system.
3. All the necessary measures must be taken to prevent leakage of fluorinated gases and to repair any leaks as soon as possible.
4. A regular check for leaks must be carried out according to the following conditions:
 - for equipment containing fluorinated greenhouse gases in quantities of 5 tonnes of CO₂ equivalent or more, but less than 50 tonnes of CO₂ equivalent: at least every twelve months or, where a leakage detection system is installed, at least every twenty-four months
 - for equipment containing fluorinated greenhouse gases in quantities of 50 tonnes of CO₂ equivalent or more, but less than 500 tonnes of CO₂ equivalent: at least every six months or, where a leakage detection system is installed, at least every twelve months
 - for equipment containing fluorinated greenhouse gases in quantities of 500 tonnes of CO₂ equivalent or more: at least every three months or, where a leakage detection system is installed, at least every six months.

8 - Technical Data (continued)

8.4 Unit electrical data

ECOi-W WQ C/H/R		20	25	30	35	40	45
Rated voltage	V/ph/Hz	400 (± 10%) / 3 / 50					
Max. absorbed power	kW	8,3	10,0	11,6	13,1	14,8	17,0
Rated current	A	9,3	12,1	14,2	13,5	15,5	21,4
Max. current FLA	A	15,0	18,2	21,6	25,0	31,0	34,0
Max. start-up current LRA	A	101,0	128,0	139,0	118,0	140,0	174,0
External fuses	A	25	25	32	32	40	40
Max. cable section ⁽¹⁾	mm ²	6	6	10	10	10	10

ECOi-W WQ C/H/R		50	60	75	90	120	150	170	190
Rated voltage	V/ph/Hz	400 (± 10%) / 3 / 50							
Max. absorbed power	kW	19,9	23,2	29,5	33,9	50,0	61,0	69,5	78,0
Rated current	A	24,3	28,4	30,9	42,8	46,0	54,0	62,1	70,2
Max. current FLA	A	36,4	43,2	62,0	68,0	88,0	106,0	119,0	132,0
Max. start-up current LRA	A	146,2	160,6	171,0	208,0	254,0	263,0	379,0	392,0
External fuses	A	80	80	100	100	160	160	200	200
Max. cable section ⁽¹⁾	mm ²	25	25	35	35	70	70	95	95

⁽¹⁾ The dimensioning of the unit's power cables is the responsibility of the installer, who shall consider: the rating, the maximum working temperature in the room, the type of insulation and the cable laying, the maximum length of the power supply line.

Compressors electrical data

ECOi-W WQ C/H/R		20	25	30	35	40	45
Number	-	1	1	1	1	1	1
Nominal power input	kW	4,6	5,8	6,7	7,4	8,5	10,1
Max. absorbed power	kW	8,3	10,0	11,6	13,1	14,8	17,0
Rated current	A	9,3	12,1	14,2	13,5	15,5	21,4
Max. current	A	15,0	18,2	21,6	25,0	31,0	34,0
Oil pan resistor	W	70	90	90	90	90	90

ECOi-W WQ C/H/R		50	60	75	90	120	150	170	190
Number	-	2	2	2	2	2	2	2	2
Nominal power input	kW	2 x 5,8	2 x 6,7	2 x 8,5	2 x 10,1	2 x 13,6	2 x 16,5	16,5+21,1	2 x 21,1
Max. absorbed power	kW	2 x 10,0	2 x 11,6	2 x 14,8	2 x 17,0	2 x 25,0	2 x 30,5	30,5 + 39,0	2 x 39,0
Rated current	A	2 x 12,1	2 x 14,2	2 x 15,5	2 x 21,4	2 x 23,0	2 x 27,0	27,0 + 35,1	2 x 35,1
Max. current	A	2 x 18,2	2 x 21,6	2 x 31,0	2 x 34,0	2 x 44,0	2 x 53,0	53,0 + 66,0	2 x 66,0
Oil pan resistor	W	2 x 90	2 x 90	2 x 90	2 x 90	2 x 140	2 x 140	2 x 140	2 x 140

8 - Technical Data (continued)

Pumps electrical data

ECOi-W WQ C/H/R -1P-SP evaporator	20	25	30	35	40	45		
Rated voltage V/ph/Hz	400 (± 10%) / 3 / 50							
Rated power kW	1,0	1,0	1,0	1,3	1,3	1,3		
Absorbed rated current FLA A	1,9	1,9	1,9	2,4	2,4	2,4		
ECOi-W WQ C/H -1P-SP condenser	20	25	30	35	40	45		
Rated voltage V/ph/Hz	400 (± 10%) / 3 / 50							
Rated power kW	1,0	1,0	1,3	1,3	1,3	1,3		
Absorbed rated current FLA A	1,9	1,9	2,4	2,4	2,4	2,4		
ECOi-W WQ C/H/R -2P-SP evaporator	50	60	75	90	120	150	170	190
Rated voltage V/ph/Hz	400 (± 10%) / 3 / 50							
Rated power kW	1,1	1,1	2,0	2,0	2,5	2,5	3,0	3,0
Absorbed rated current FLA A	2,0	2,0	3,4	3,4	4,5	4,5	6,3	6,3
ECOi-W WQ C/H -2P-SP condenser	50	60	75	90	120	150	170	190
Rated voltage V/ph/Hz	400 (± 10%) / 3 / 50							
Rated power kW	1,1	1,1	2,0	2,0	2,5	3,0	3,0	4,0
Absorbed rated current FLA A	2,0	2,0	3,4	3,4	4,5	6,3	6,3	7,7
ECOi-W WQ C/H/R -2P-HP evaporator	50	60	75	90	120	150	170	190
Rated voltage V/ph/Hz	400 (± 10%) / 3 / 50							
Rated power kW	2,2	2,2	3,3	3,3	3,0	3,0	4,0	4,0
Absorbed rated current FLA A	4,2	4,2	5,9	5,9	6,3	6,3	7,7	7,7
ECOi-W WQ C/H -2P-HP condenser	50	60	75	90	120	150	170	190
Rated voltage V/ph/Hz	400 (± 10%) / 3 / 50							
Rated power kW	2,2	2,2	3,3	3,3	3,0	4,0	5,5	5,5
Absorbed rated current FLA A	4,2	4,2	5,9	5,9	6,3	7,7	10,4	10,4

8 - Technical Data (continued)

8.5 Hydraulic Features

ECOi-W WQ 20-45 C/H/R available static pressure - internal heat exchanger (1P.E)

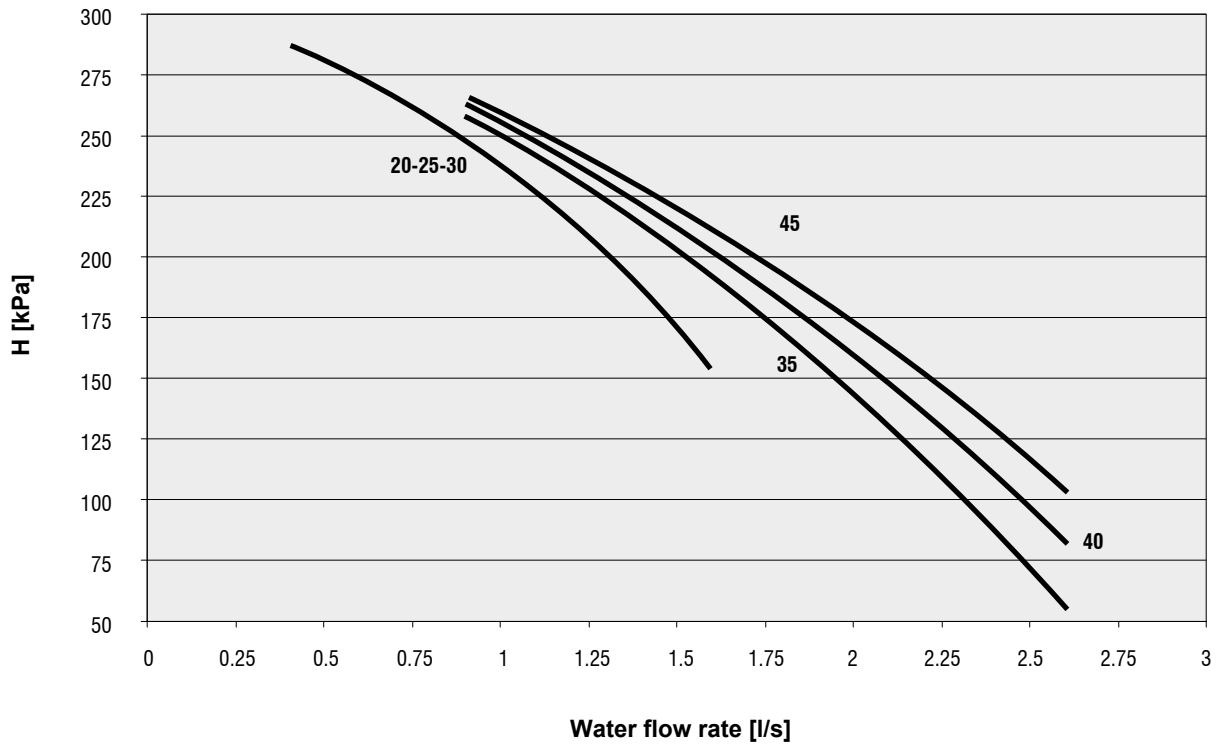

ECOi-W WQ 20-45 C/H available static pressure - external heat exchanger (1P.C)

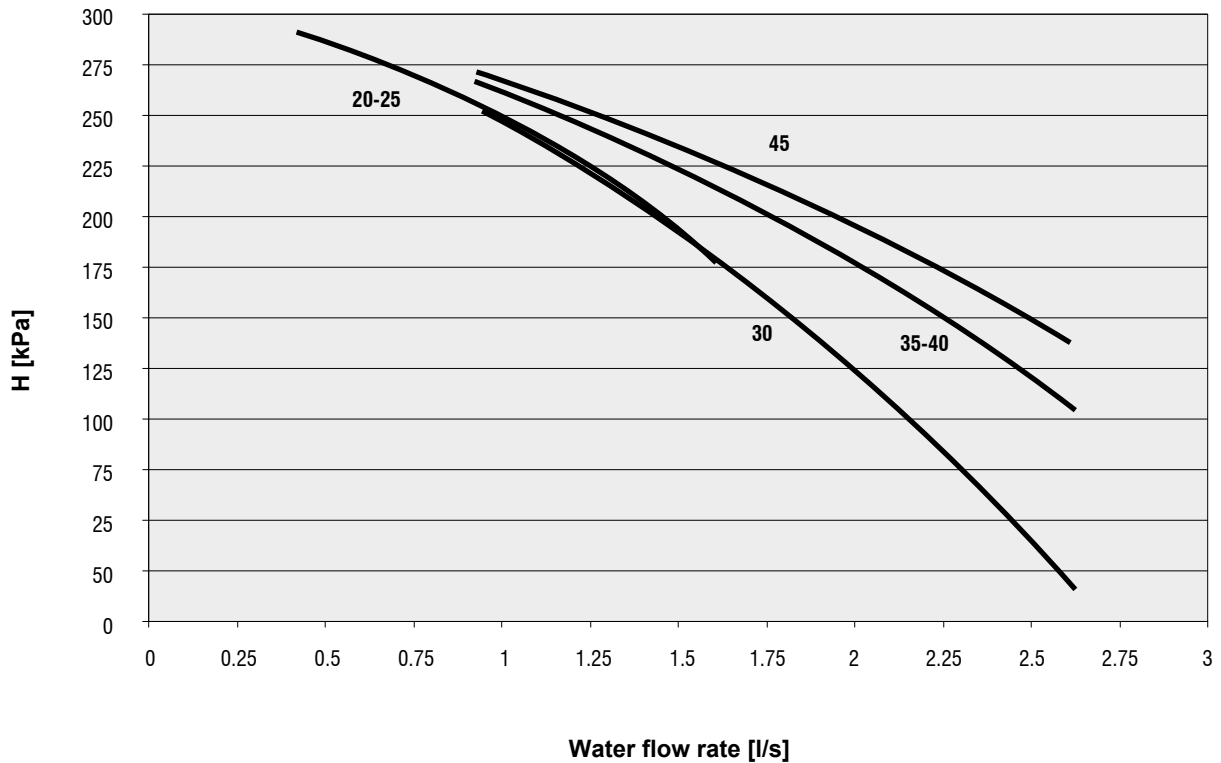

8 - Technical Data (continued)

ECOi-W WQ 50-190 C/H/R available static pressure - internal heat exchanger (1/2P-SP.E)

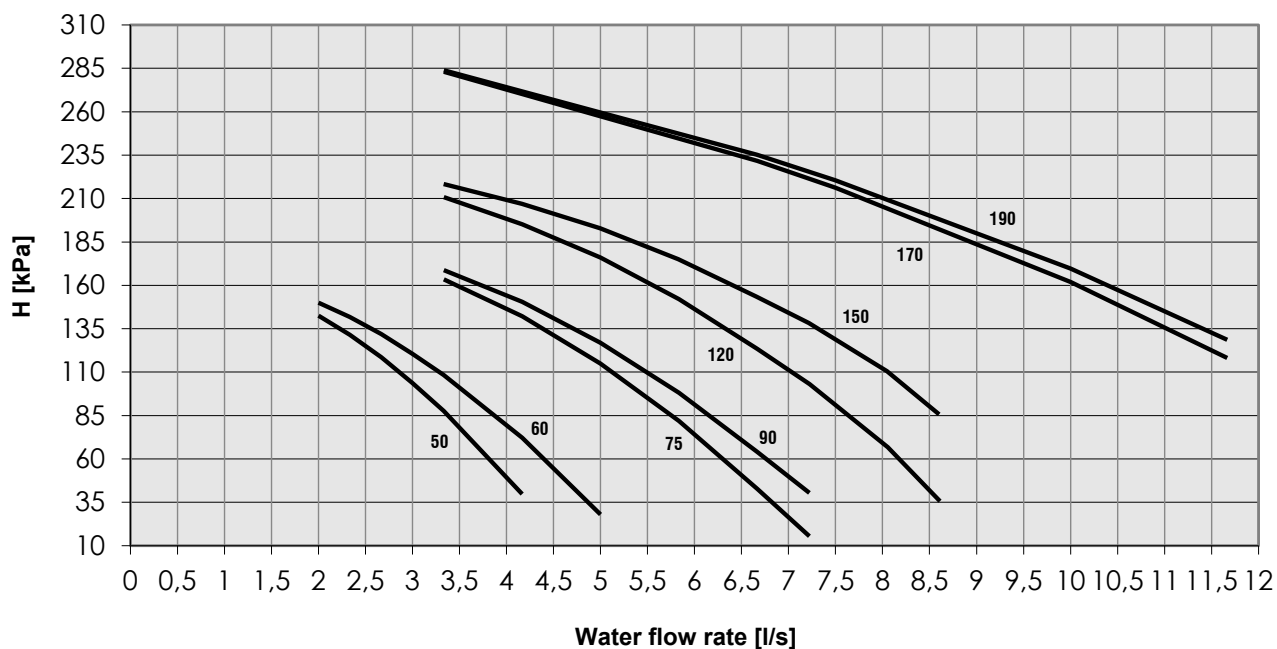

ECOi-W WQ 50-190 C/H available static pressure - external heat exchanger (1/2P-SP.C)

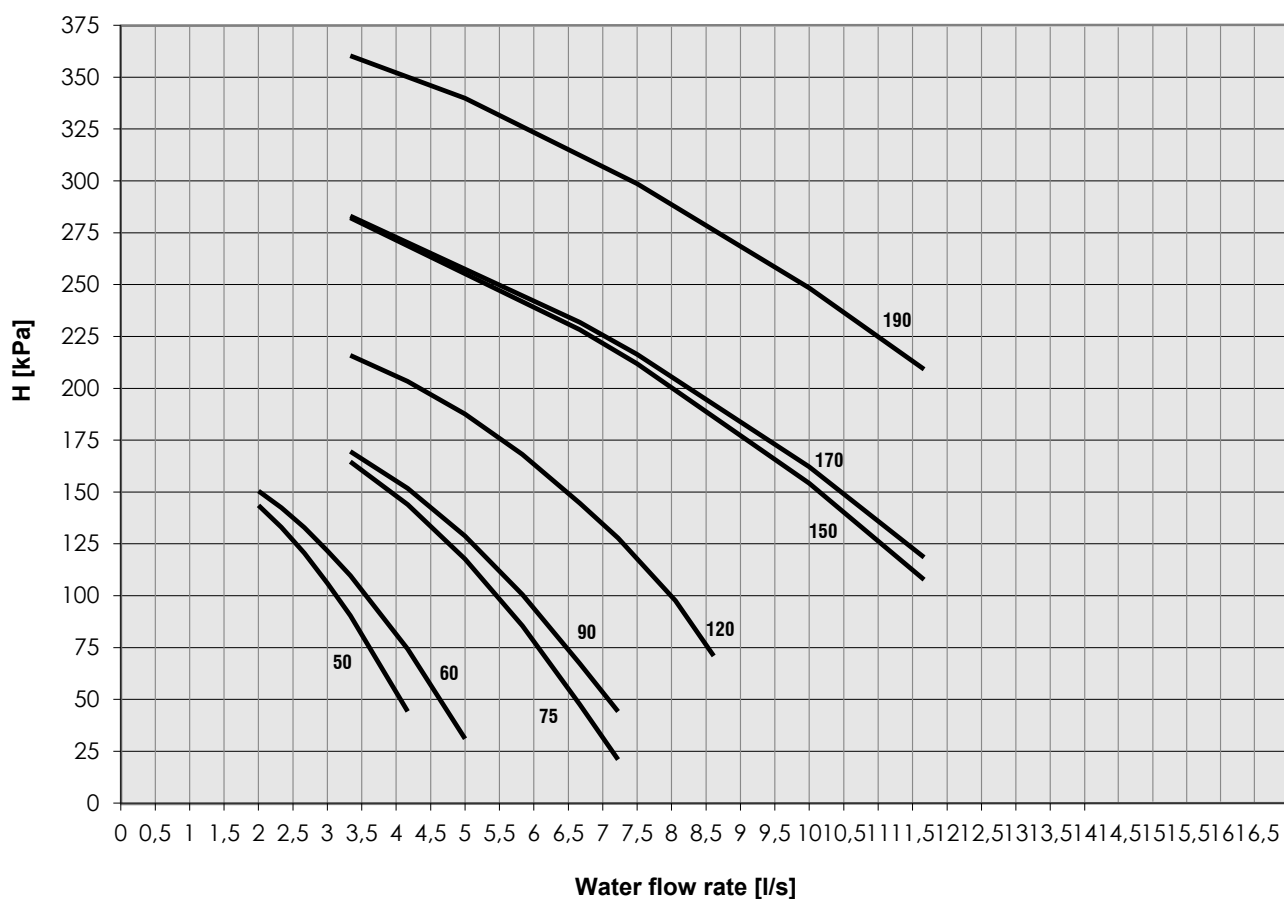

8 - Technical Data (continued)

ECOi-W WQ 50-190 C/H/R available static pressure - internal heat exchanger (1/2P-HP.E)

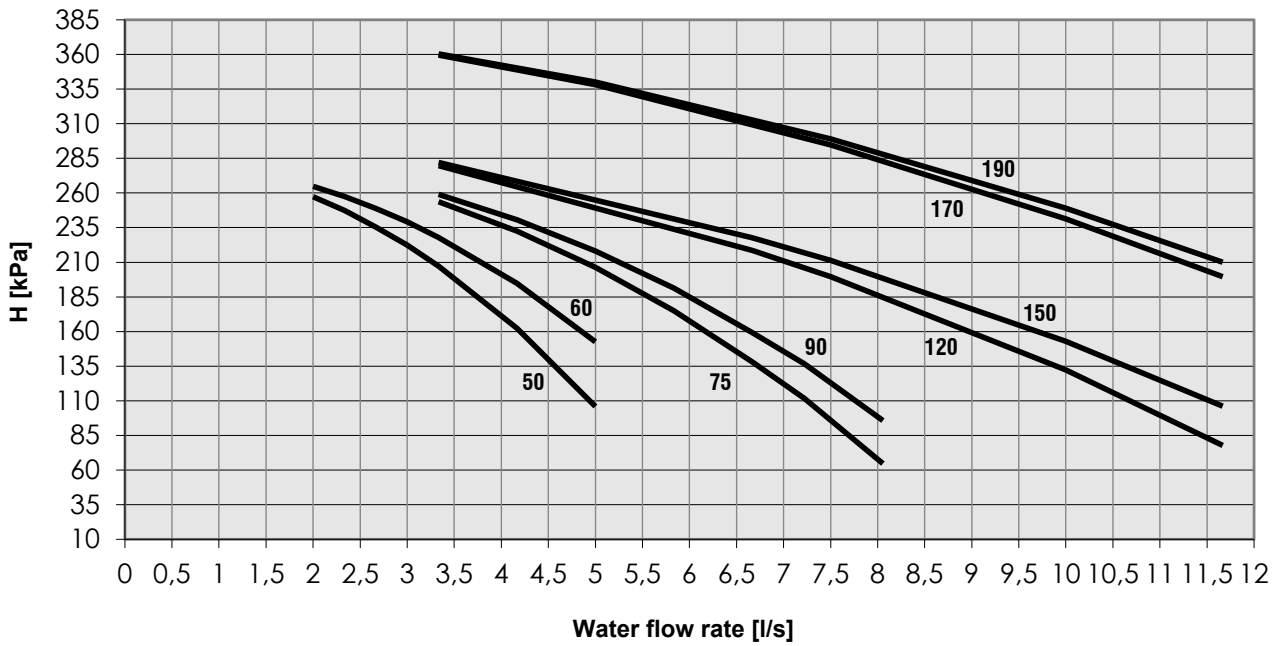

ECOi-W WQ 50-190 C/H/R available static pressure - external heat exchanger (1/2P-HP.C)

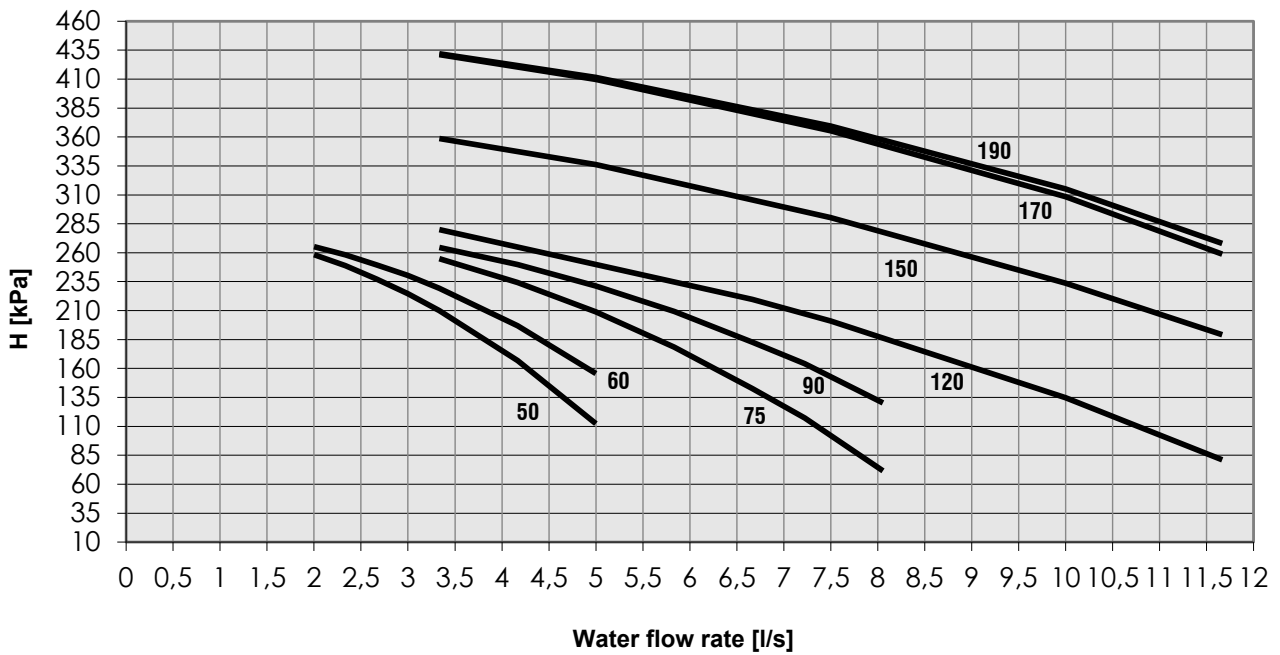

8 - Technical Data (continued)

ECOi-W WQ 20-45 C/H/R - internal heat exchanger pressure drop

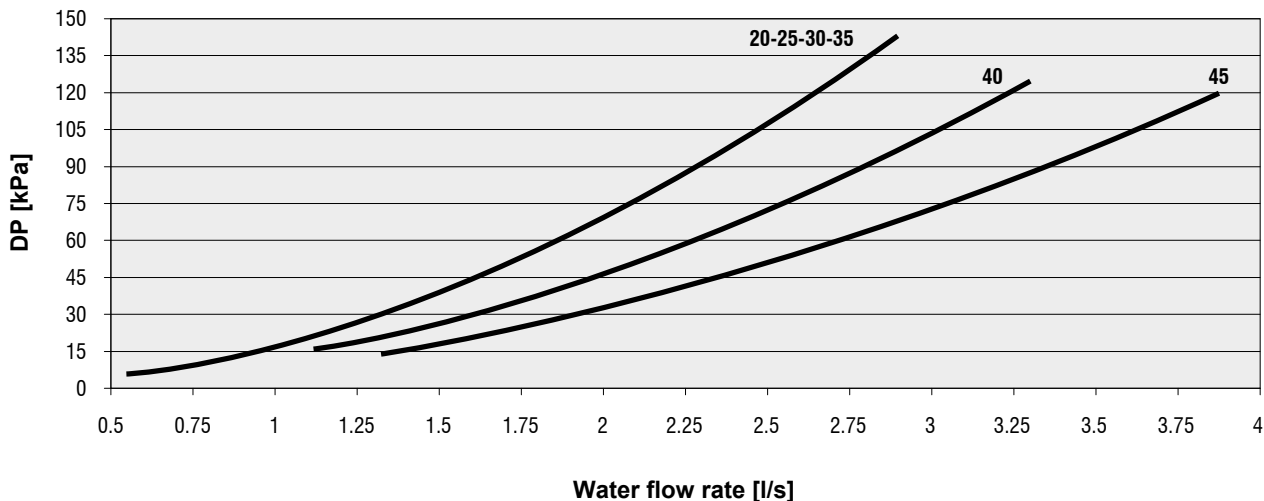

ECOi-W WQ 20-45 C/H - external heat exchanger pressure drop

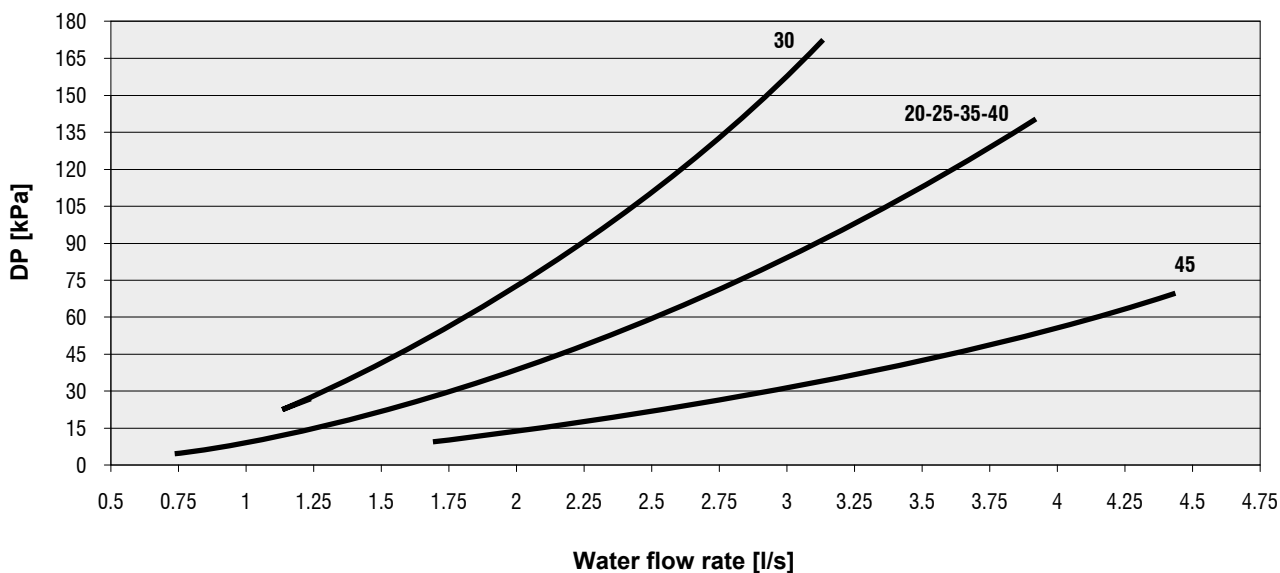

ECOi-W WQ 50-190 C/H/R - internal heat exchanger pressure drop

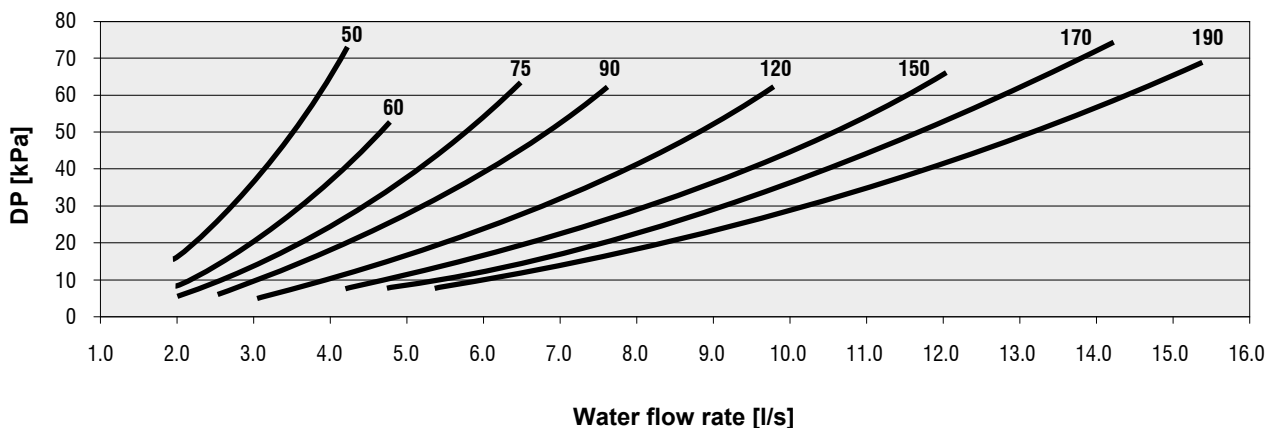

8 - Technical Data (continued)

ECOi-W WQ 50-190 C/H - external heat exchanger pressure drop

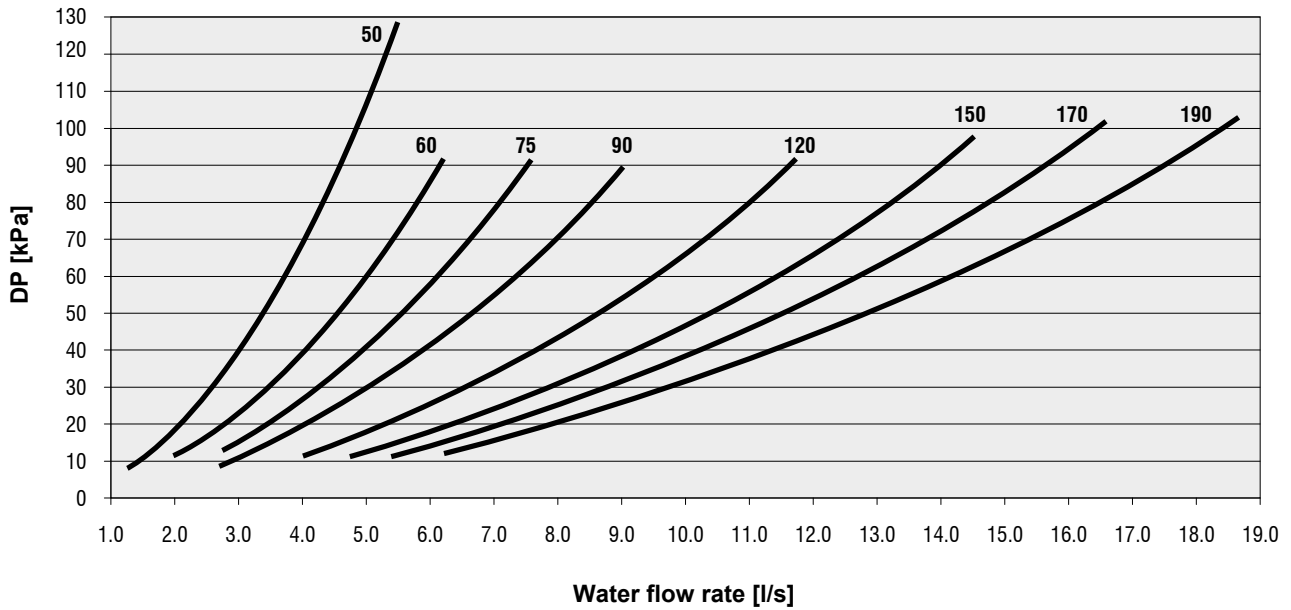

ECOi-W WQ 50-190 C/H/R - desuperheater pressure drop

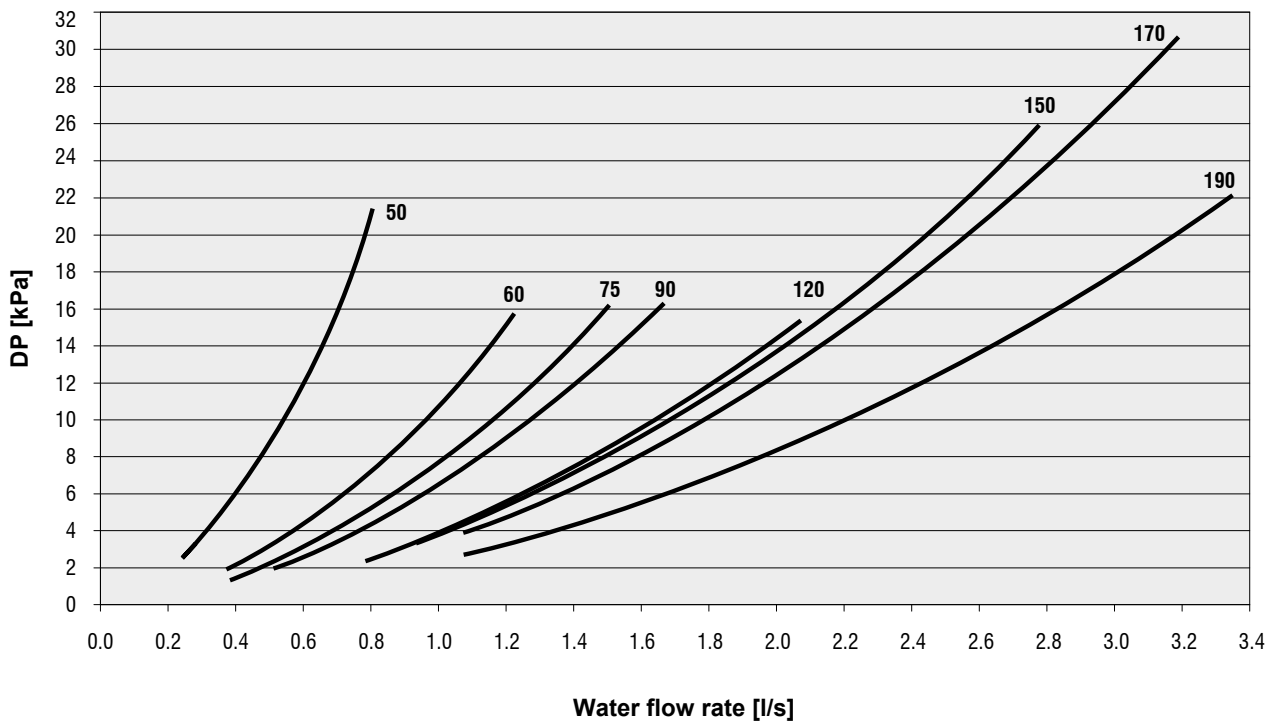

8 - Technical Data (continued)

8.6 Position of shock adsorbers and weight distribution on supports

ECOi-W WQ 20-45 C/H/R	Weight distribution (kg)				Operating weight (kg)	Shipping weight (kg)	P1-P4 coordinates		CG coordinates	
	P1	P2	P3	P4			a (mm)	b (mm)	x (mm)	y (mm)
45 STD	54	44	63	53	214	203	400	785	203	376
40 STD	45	43	53	51	191	185	400	785	217	378
35 STD	43	42	50	49	185	179	400	785	220	380
30 STD	40	42	48	49	179	174	400	785	224	377
25 STD	42	42	49	48	182	176	400	785	220	382
20 STD	39	40	41	42	162	156	400	785	222	402
45 1P.C	59	51	64	56	231	220	400	785	207	394
40 1P.C	51	50	54	53	208	202	400	785	221	399
35 1P.C	49	50	51	52	202	196	400	785	223	401
30 1P.C	46	49	49	52	196	191	400	785	227	399
25 1P.C	48	49	50	51	198	193	400	785	223	403
20 1P.C	45	47	42	44	179	173	400	785	226	423
45 1P.E	60	52	65	56	233	222	400	785	207	396
40 1P.E	51	51	54	53	209	204	400	785	220	401
35 1P.E	50	50	52	52	203	197	400	785	222	403
30 1P.E	47	49	49	52	197	192	400	785	226	401
25 1P.E	49	50	50	51	200	194	400	785	222	405
20 1P.E	46	48	43	44	181	175	400	785	225	426
45 2P	66	59	66	59	250	239	400	785	210	412
40 2P	57	58	55	56	227	221	400	785	223	418
35 2P	56	57	53	55	220	214	400	785	225	421
30 2P	53	57	50	54	214	210	400	785	229	419
25 2P	55	57	52	54	217	211	400	785	225	422
20 2P	52	55	44	47	197	191	400	785	228	443

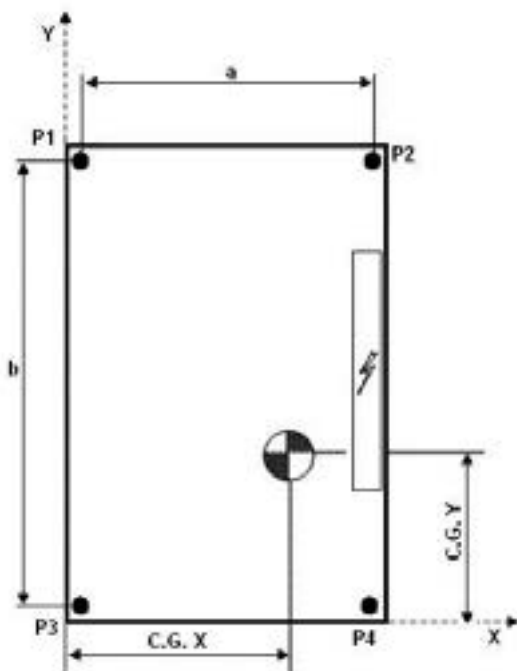

- STD → basic unit (no pumps)
- 1P.C → one pump / condenser
- 1P.E → one pump / evaporator
- 2P → two pumps (evaporator and condenser)

8 - Technical Data (continued)

	ECOI-W WQ 20-45 C/H/R	Weight distribution (kg)				Operating weight (kg)	Shipping weight (kg)	P1-P4 coordinates		CG coordinates	
		P1	P2	P3	P4			a (mm)	b (mm)	x (mm)	y (mm)
ECOI-W WQ H	45 STD	55	44	65	55	219	208	400	785	202	372
	40 STD	46	43	55	52	195	190	400	785	216	375
	35 STD	44	42	53	51	190	184	400	785	218	376
	30 STD	42	42	50	51	184	179	400	785	222	373
	25 STD	44	42	51	50	187	181	400	785	218	378
	20 STD	40	40	43	42	165	159	400	785	221	399
	45 1P.C	61	52	67	58	236	225	400	785	206	391
	40 1P.C	52	50	56	55	213	207	400	785	219	395
	35 1P.C	50	50	54	54	207	201	400	785	221	397
	30 1P.C	47	49	51	53	201	197	400	785	225	395
	25 1P.C	49	49	53	53	204	198	400	785	221	398
	20 1P.C	46	47	44	45	182	176	400	785	225	420
	45 1P.E	62	52	67	57	238	227	400	785	205	393
	40 1P.E	53	51	56	54	214	208	400	785	219	397
	35 1P.E	51	50	54	53	209	203	400	785	220	399
	30 1P.E	48	50	52	53	203	198	400	785	224	397
	25 1P.E	50	50	53	52	205	199	400	785	221	401
	20 1P.E	47	48	44	45	184	178	400	785	224	422
	45 2P	67	59	68	60	255	244	400	785	209	409
	40 2P	58	58	57	57	231	226	400	785	222	414
35 2P	57	58	55	56	226	220	400	785	223	416	
30 2P	54	57	53	56	220	215	400	785	227	415	
25 2P	56	57	54	55	222	216	400	785	223	418	
20 2P	53	55	45	48	201	195	400	785	227	440	
ECOI-W WQ R	45 STD	33	39	47	53	172	168	400	785	234	346
	40 STD	34	39	47	52	172	169	400	785	232	352
	35 STD	32	38	45	50	166	163	400	785	236	354
	30 STD	33	38	45	50	166	163	400	785	236	353
	25 STD	32	38	44	50	164	161	400	785	236	355
	20 STD	29	36	36	43	144	142	400	785	241	375
	45 1P.E	40	46	49	55	190	186	400	785	235	375
	40 1P.E	34	39	47	52	191	188	400	785	233	379
	35 1P.E	32	38	45	50	184	182	400	785	237	382
	30 1P.E	33	38	45	50	184	182	400	785	237	382
	25 1P.E	32	38	44	50	182	180	400	785	237	384
	20 1P.E	29	36	36	43	163	160	400	785	242	404

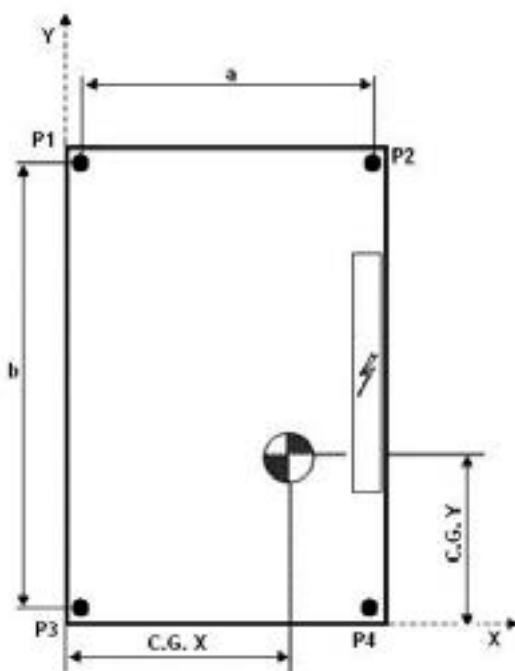

- STD → basic unit (no pumps)
- 1P.C → one pump / condenser
- 1P.E → one pump / evaporator
- 2P → two pumps (evaporator and condenser)

8 - Technical Data (continued)

	ECOI-W WQ 50-190 C/H/R (BASIC UNIT)	Weight distribution (kg)				Operating weight (kg)	Shipping weight (kg)	P1-P4 coordinates		CG coordinates	
		P1	P2	P3	P4			a (mm)	b (mm)	x (mm)	y (mm)
ECOI-W WQ C	50	114	123	53	62	352	345	796	600	443	704
	60	127	131	55	59	371	361	796	600	432	716
	75	138	138	58	57	392	380	796	600	423	724
	90	150	145	60	55	411	397	796	600	413	731
	120	212	224	74	86	597	578	796	600	439	739
	150	240	249	84	93	666	642	796	600	434	740
	170	255	260	90	95	701	673	796	600	429	741
	190	275	273	100	98	745	713	796	600	421	741
ECOI-W WQ H	50	117	124	56	63	360	353	796	600	438	702
	60	130	132	58	60	379	369	796	600	427	714
	75	143	139	62	59	403	391	796	600	416	720
	90	155	146	65	56	422	408	796	600	407	728
	120	217	226	79	88	610	591	796	600	434	736
	150	247	251	91	95	683	659	796	600	428	737
	170	262	262	97	97	718	691	796	600	423	738
	190	282	274	107	99	762	730	796	600	415	738
ECOI-W WQ R	50	94	111	55	72	332	329	796	600	462	670
	60	101	115	57	71	344	339	796	600	456	677
	75	110	121	62	72	365	359	796	600	446	680
	90	117	125	63	71	376	369	796	600	440	685
	120	173	200	79	106	558	548	796	600	462	701
	150	191	220	86	115	612	600	796	600	461	703
	170	202	230	92	119	643	629	796	600	457	703
	190	214	239	97	123	674	658	796	600	453	704

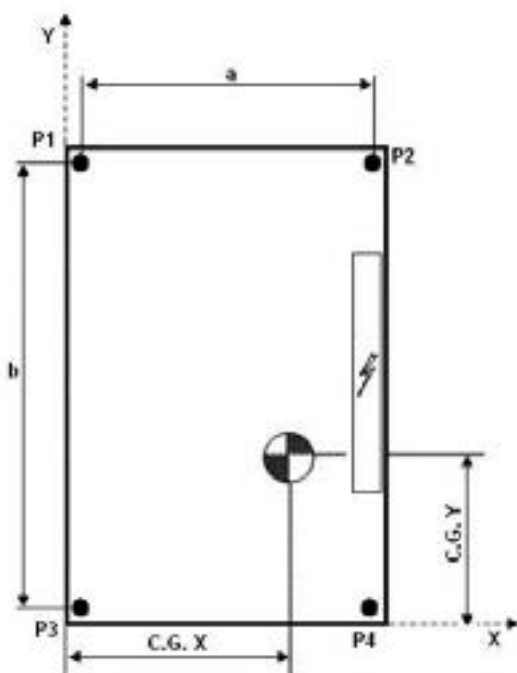

- STD → basic unit (no pumps)
- 1P.C → one pump / condenser
- 1P.E → one pump / evaporator
- 2P → two pumps (evaporator and condenser)

8 - Technical Data (continued)

	ECOI-W WQ 50-190 C/H/R (HYDRONIC OPTIONS)	Weight distribution (kg)				Operating weight (kg)	Shipping weight (kg)	P5-P8 coordinates		CG coordinates	
		P5	P6	P7	P8			a (mm)	b (mm)	x (mm)	y (mm)
50	1P SP.E	43	44	35	36	158	131	796	380	429	392
	1P SP.E 1P SP.C	45	47	39	41	172	137	796	380	435	386
	1P SP.C	37	39	30	31	136	128	796	380	430	395
	2P SP.E	46	48	40	42	176	148	796	380	435	386
	2P SP.E 2P SP.C	50	56	48	54	208	171	796	380	445	377
	2P SP.C	40	43	34	37	155	145	796	380	437	388
	1P HP.E	43	44	35	36	159	133	796	380	429	392
	1P HP.E 1P HP.C	45	48	39	42	175	140	796	380	437	385
	1P HP.C	38	39	30	31	138	130	796	380	430	394
	2P HP.E	46	49	40	43	179	151	796	380	436	385
	2P HP.E 2P HP.C	51	57	50	56	214	176	796	380	447	375
	2P HP.C	41	44	35	38	157	148	796	380	438	386
60	1P SP.E	43	44	35	36	158	131	796	380	429	392
	1P SP.E 1P SP.C	45	47	39	41	172	137	796	380	435	386
	1P SP.C	37	39	30	31	136	128	796	380	430	395
	2P SP.E	46	48	40	42	176	148	796	380	435	386
	2P SP.E 2P SP.C	50	56	48	54	208	171	796	380	445	377
	2P SP.C	40	43	34	37	155	145	796	380	437	388
	1P HP.E	43	44	35	36	159	133	796	380	429	392
	1P HP.E 1P HP.C	45	48	39	42	175	140	796	380	437	385
	1P HP.C	38	39	30	31	138	130	796	380	430	394
	2P HP.E	46	49	40	43	179	151	796	380	436	385
	2P HP.E 2P HP.C	51	57	50	56	214	176	796	380	447	375
	2P HP.C	41	44	35	38	157	148	796	380	438	386

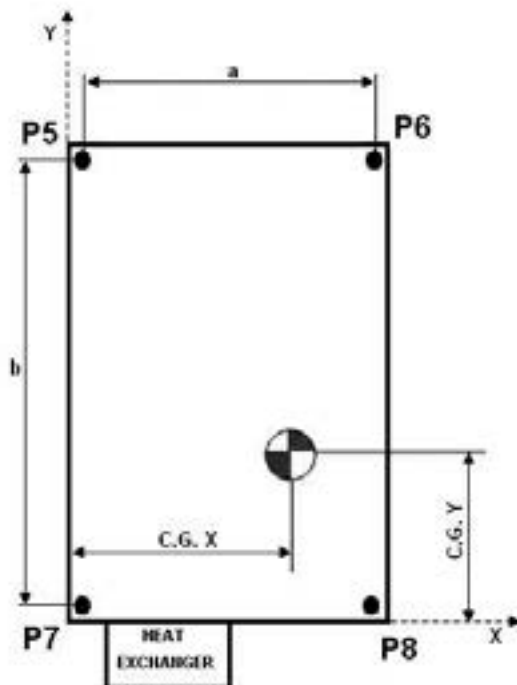

1P SP.E → one pump / standard pressure / evaporator
 1P SP.C → one pump / standard pressure / condenser
 2P SP.E → two pumps / standard pressure / evaporator
 2P SP.C → two pumps / standard pressure / condenser
 1P HP.E → one pump / high pressure / evaporator
 1P HP.C → one pump / high pressure / condenser
 2P HP.E → two pumps / high pressure / evaporator
 2P HP.C → two pumps / high pressure / condenser

8 - Technical Data (continued)

	ECOi-W WQ 50-190 C/H/R (HYDRONIC OPTIONS)	Weight distribution (kg)				Operating weight (kg)	Shipping weight (kg)	P5-P8 coordinates		CG coordinates	
		P5	P6	P7	P8			a (mm)	b (mm)	x (mm)	y (mm)
75	1P SP.E	43	45	36	37	161	134	796	380	430	391
	1P SP.E 1P SP.C	45	49	40	44	178	144	796	380	438	384
	1P SP.C	38	39	30	32	139	131	796	380	431	393
	2P SP.E	46	50	41	45	182	154	796	380	438	384
	2P SP.E 2P SP.C	52	59	51	59	221	183	796	380	449	373
	2P SP.C	41	44	36	39	161	151	796	380	440	385
	1P HP.E	44	46	37	39	166	139	796	380	433	389
	1P HP.E 1P HP.C	46	51	43	47	188	153	796	380	442	380
	1P HP.C	38	40	32	34	144	136	796	380	434	391
	2P HP.E	48	52	44	48	192	164	796	380	442	380
	2P HP.E 2P HP.C	54	63	57	66	240	203	796	380	454	369
	2P HP.C	42	47	39	43	171	161	796	380	444	381
90	1P SP.E	43	45	36	37	161	134	796	380	430	391
	1P SP.E 1P SP.C	45	49	40	44	178	144	796	380	438	384
	1P SP.C	38	39	30	32	139	131	796	380	431	393
	2P SP.E	46	50	41	45	182	154	796	380	438	384
	2P SP.E 2P SP.C	52	59	51	59	221	183	796	380	449	373
	2P SP.C	41	44	36	39	161	151	796	380	440	385
	1P HP.E	44	46	37	39	166	139	796	380	433	409
	1P HP.E 1P HP.C	46	51	43	47	188	153	796	380	442	414
	1P HP.C	38	40	32	34	144	136	796	380	434	416
	2P HP.E	48	52	44	48	192	164	796	380	442	415
	2P HP.E 2P HP.C	54	63	57	66	240	203	796	380	454	418
	2P HP.C	42	47	39	43	171	161	796	380	444	440

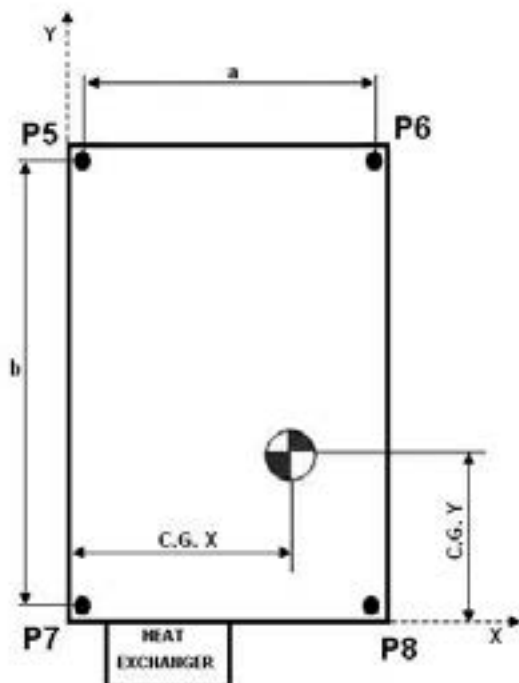

1P SP.E → one pump / standard pressure / evaporator
 1P SP.C → one pump / standard pressure / condenser
 2P SP.E → two pumps / standard pressure / evaporator
 2P SP.C → two pumps / standard pressure / condenser
 1P HP.E → one pump / high pressure / evaporator
 1P HP.C → one pump / high pressure / condenser
 2P HP.E → two pumps / high pressure / evaporator
 2P HP.C → two pumps / high pressure / condenser

8 - Technical Data (continued)

	ECOI-W WQ 50-190 C/H/R (HYDRONIC OPTIONS)	Weight distribution (kg)				Operating weight (kg)	Shipping weight (kg)	P5-P8 coordinates		CG coordinates	
		P5	P6	P7	P8			a (mm)	b (mm)	x (mm)	y (mm)
120	1P SP.E	43	45	36	38	162	136	796	380	431	390
	1P SP.E 1P SP.C	46	49	41	45	181	147	796	380	439	383
	1P SP.C	38	40	31	32	141	133	796	380	432	392
	2P SP.E	47	50	42	46	185	157	796	380	439	383
	2P SP.E 2P SP.C	52	60	53	61	227	190	796	380	451	372
	2P SP.C	41	45	37	41	164	154	796	380	441	384
	1P HP.E	47	51	43	47	188	160	796	380	441	381
	1P HP.E 1P HP.C	53	62	55	64	233	195	796	380	454	369
	1P HP.C	41	46	38	42	167	157	796	380	443	382
	2P HP.E	55	64	57	66	243	210	796	380	452	370
	2P HP.E 2P HP.C	70	88	84	102	344	295	796	380	465	357
	2P HP.C	50	59	52	61	222	207	796	380	455	369
	150	1P SP.E	43	45	36	38	162	136	796	380	431
1P SP.E 1P SP.C		49	56	48	54	207	171	796	380	447	375
1P SP.C		41	46	38	42	167	157	796	380	443	382
2P SP.E		47	50	42	46	185	157	796	380	439	383
2P SP.E 2P SP.C		61	74	69	82	285	242	796	380	459	363
2P SP.C		50	59	52	61	222	207	796	380	455	369
1P HP.E		47	51	43	47	188	160	796	380	441	381
1P HP.E 1P HP.C		53	63	57	66	240	202	796	380	455	368
1P HP.C		42	47	40	45	174	164	796	380	446	379
2P HP.E		55	64	57	66	243	210	796	380	452	370
2P HP.E 2P HP.C		71	91	88	108	358	309	796	380	467	356
2P HP.C		52	62	56	67	236	221	796	380	459	366

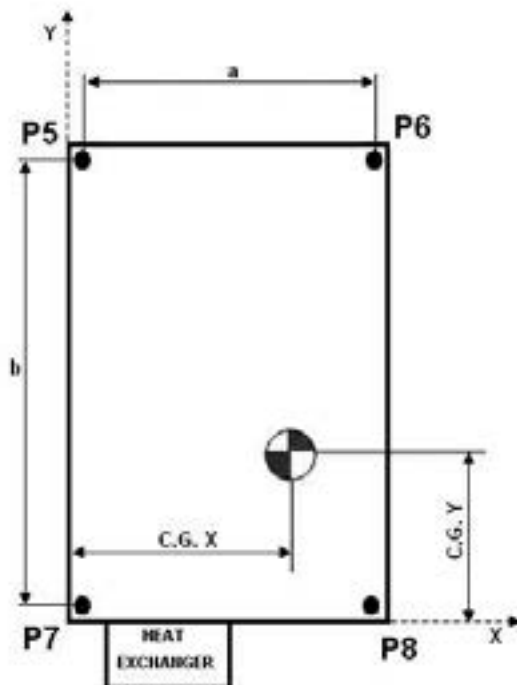

1P SP.E → one pump / standard pressure / evaporator
 1P SP.C → one pump / standard pressure / condenser
 2P SP.E → two pumps / standard pressure / evaporator
 2P SP.C → two pumps / standard pressure / condenser
 1P HP.E → one pump / high pressure / evaporator
 1P HP.C → one pump / high pressure / condenser
 2P HP.E → two pumps / high pressure / evaporator
 2P HP.C → two pumps / high pressure / condenser

8 - Technical Data (continued)

	ECOI-W WQ 50-190 C/H/R (HYDRONIC OPTIONS)	Weight distribution (kg)				Operating weight (kg)	Shipping weight (kg)	P5-P8 coordinates		CG coordinates	
		P5	P6	P7	P8			a (mm)	b (mm)	x (mm)	y (mm)
170	1P SP.E	47	51	43	47	188	160	796	380	441	381
	1P SP.E 1P SP.C	53	62	55	64	233	195	796	380	454	369
	1P SP.C	41	46	38	42	167	157	796	380	443	382
	2P SP.E	55	64	57	66	243	210	796	380	452	370
	2P SP.E 2P SP.C	70	88	84	102	344	295	796	380	465	357
	2P SP.C	50	59	52	61	222	207	796	380	455	369
	1P HP.E	48	53	45	50	195	167	796	380	444	379
	1P HP.E 1P HP.C	56	68	63	75	262	224	796	380	461	363
	1P HP.C	44	51	44	50	189	179	796	380	452	374
	2P HP.E	57	68	61	72	257	224	796	380	456	367
	2P HP.E 2P HP.C	76	101	99	124	402	353	796	380	473	351
	2P HP.C	55	69	64	78	266	251	796	380	465	360
190	1P SP.E	47	51	43	47	188	160	796	380	441	381
	1P SP.E 1P SP.C	53	63	57	66	240	202	796	380	455	368
	1P SP.C	42	47	40	45	174	164	796	380	446	379
	2P SP.E	55	64	57	66	243	210	796	380	452	370
	2P SP.E 2P SP.C	71	91	88	108	358	309	796	380	467	356
	2P SP.C	52	62	56	67	236	221	796	380	459	366
	1P HP.E	48	53	45	50	195	167	796	380	444	379
	1P HP.E 1P HP.C	56	68	63	75	262	224	796	380	461	363
	1P HP.C	44	51	44	50	189	179	796	380	452	374
	2P HP.E	57	68	61	72	257	224	796	380	456	367
	2P HP.E 2P HP.C	76	101	99	124	402	353	796	380	473	351
	2P HP.C	55	69	64	78	266	251	796	380	465	360

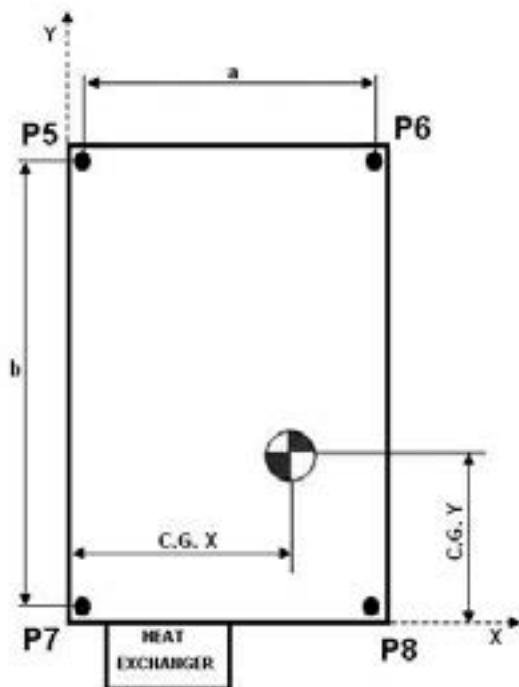

- 1P SP.E → one pump / standard pressure / evaporator
- 1P SP.C → one pump / standard pressure / condenser
- 2P SP.E → two pumps / standard pressure / evaporator
- 2P SP.C → two pumps / standard pressure / condenser
- 1P HP.E → one pump / high pressure / evaporator
- 1P HP.C → one pump / high pressure / condenser
- 2P HP.E → two pumps / high pressure / evaporator
- 2P HP.C → two pumps / high pressure / condenser

8 - Technical Data (continued)

8.7 Dimensional drawings

ECOi-W WQ 20-45 C/H/R

Side view

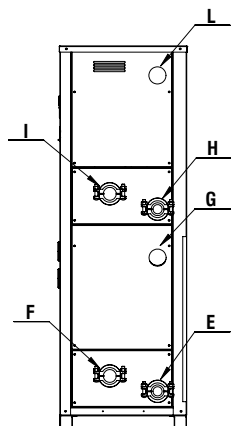

Side view

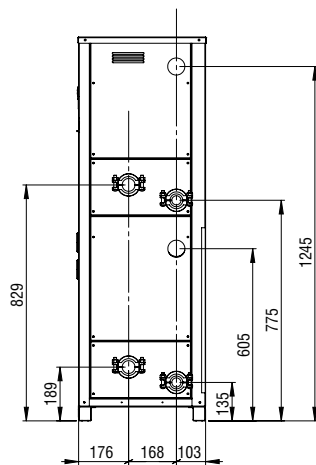

Front view

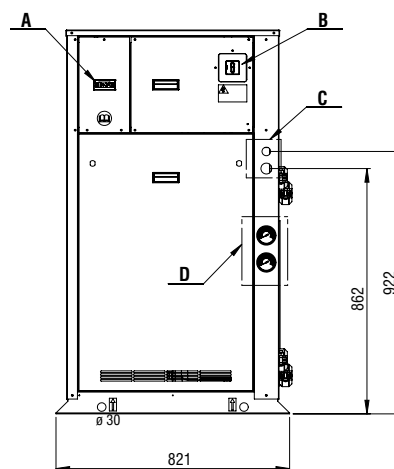

Side view

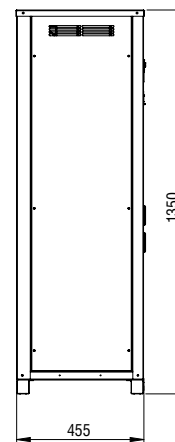

Top view

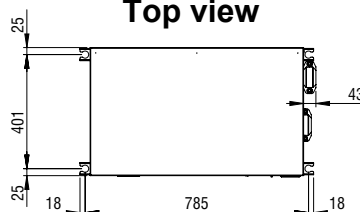

A	Control display
B	Main switch
C	Auxiliary lines, electrical connection
D	Gauge kit
E, F, G	Internal heat exchanger connections Ø1 1/2" Victaulic
H, I, L	External heat connections Ø1 1/2" Victaulic

		REFRIGERANT CONNECTIONS		
		IN	OUT	
ECOi-W WQ 20 R		H Ø 5/8"	L Ø 5/8"	
ECOi-W WQ 25 - 45 R		H Ø 5/8"	L Ø 7/8"	
WATER CONNECTIONS				
INT. H.E.		EXT. H.E.		
IN	OUT	IN	OUT	
BASIC UNIT	G	E	L	H
UNIT WITH PUMP	F	E	I	H

8 - Technical Data (continued)

ECOi-W WQ 50-190 C/H/R (without hydrokit)

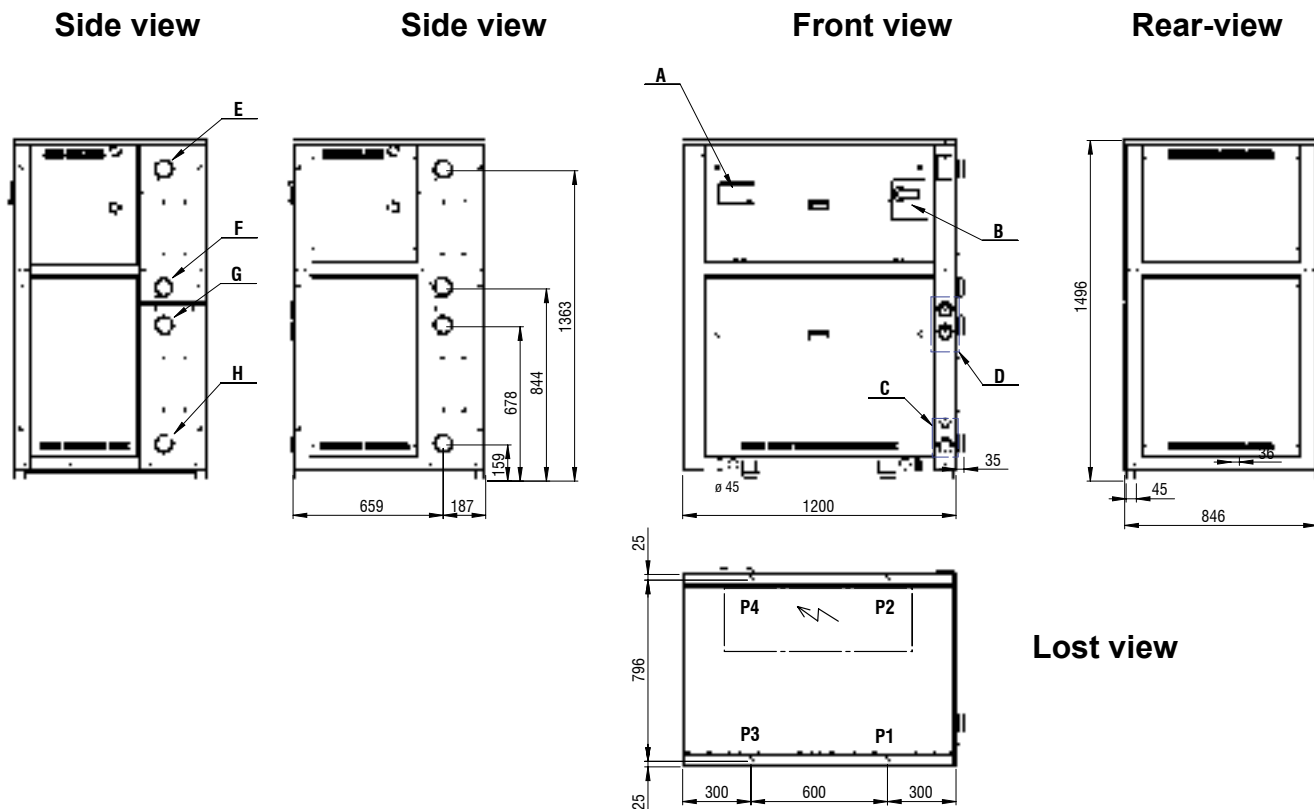

A	Control display
B	Main switch
C	Auxiliary lines, electrical connection
D	Gauge kit
G, H	Internal heat exchanger connections Ø2 1/2" Victaulic (Ø76.1 MM)
E, F	External heat connections Ø2 1/2" Victaulic (Ø76.1 MM)

WATER CONNECTIONS			
INT. H.E.		EXT. H.E.	
IN	OUT	IN	OUT
G	H	E	F

8 - Technical Data (continued)

ECOi-W WQ 50-190 C/H/R (with hydrokit)

Side view

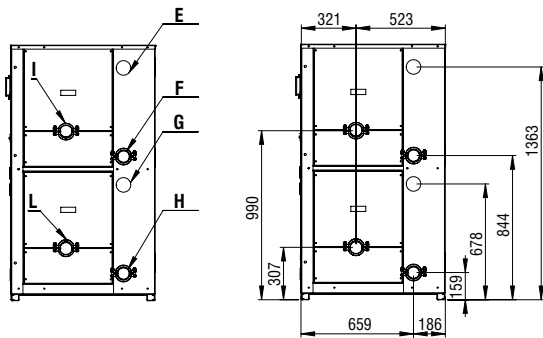

Front view

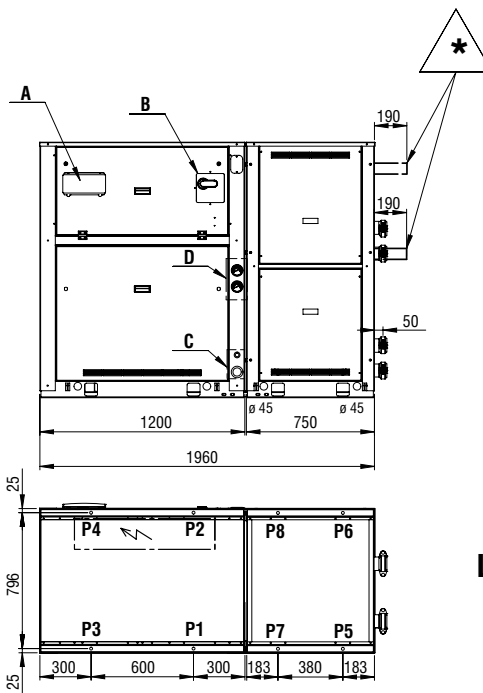

Rear-view

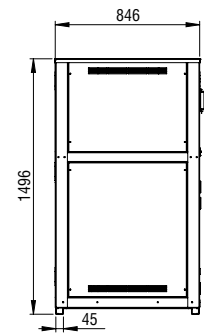

Low view

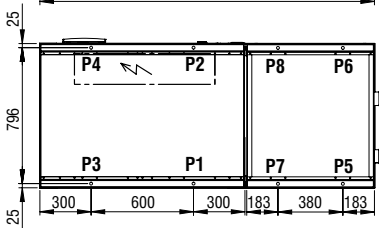

* Only for ECOi-W WQ R - for transport

A	Control display
B	Main switch
C	Auxiliary lines, electrical connection
D	Gauge kit
G, H, L	Internal heat exchanger connections Ø2 1/2" Victaulic (Ø76.1 MM)
E, F, I	External heat connections Ø2 1/2" Victaulic (Ø76.1 MM)

	REFRIGERANT CONNECTIONS				
	IN		OUT		
ECOi-W WQ 170-190 R	F Ø 1 1/8"		E Ø 1 5/8"		
ECOi-W WQ 150 R	F Ø 7/8"		E Ø 1 5/8"		
ECOi-W WQ 120 R	F Ø 7/8"		E Ø 1 3/8"		
ECOi-W WQ 75-90 R	F Ø 7/8"		E Ø 1 1/8"		
ECOi-W WQ 50-60 R	F Ø 5/8"		E Ø 7/8"		
WATER CONNECTIONS					
		INT. H.E.		EXT. H.E.	
	IN	OUT	IN	OUT	
BASIC UNIT	G	H	E	F	
UNIT WITH PUMP	L	H	I	F	

8 - Technical Data (continued)

8.8 Unit clearances (in mm)

ECOi-W WQ 20-45 C/H/R

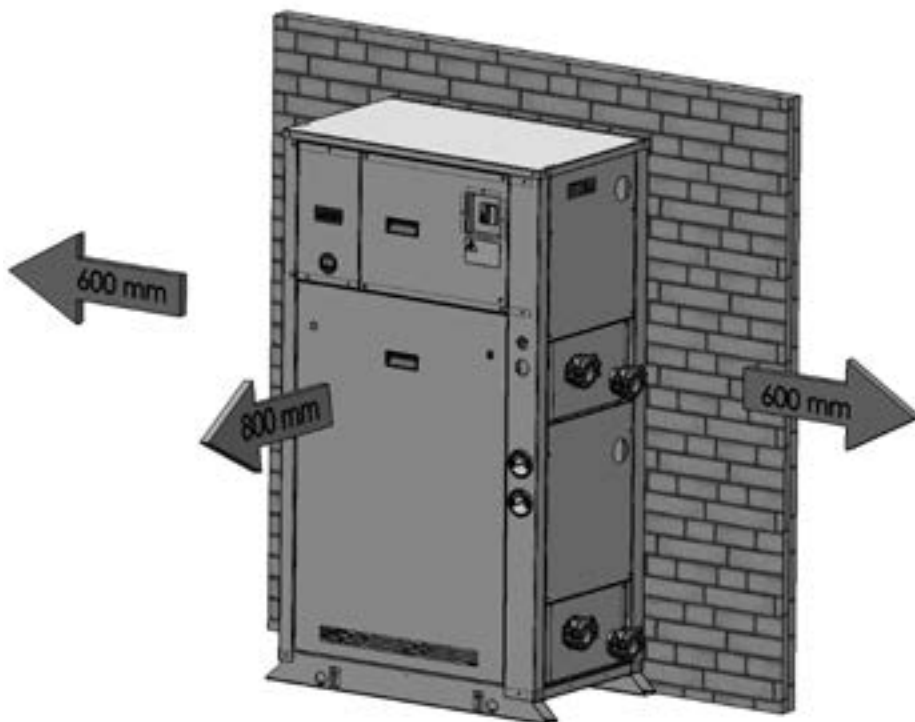

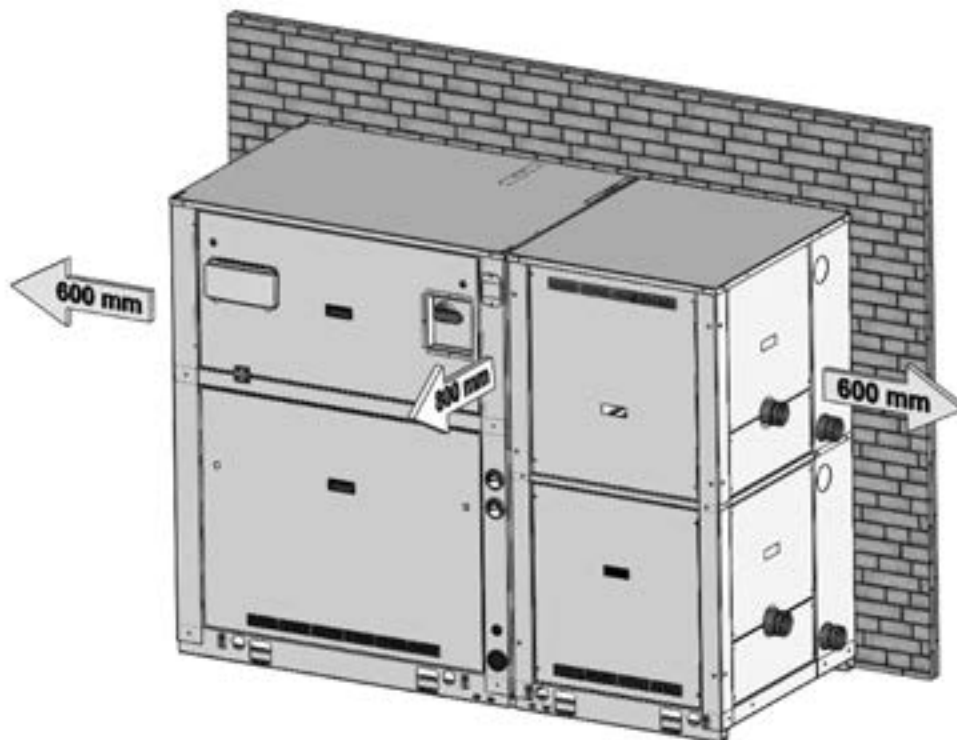

ECOi-W WQ 50-190 C/H/R



9 - Maintenance

Carefully read the section "2 - Safety" of this manual before carrying out any maintenance operations.

 DANGER	<p>Do not discharge the refrigerant into the atmosphere while the refrigeration circuits are being drained. Use appropriate recovery equipment.</p> <p>When the recovered refrigerant cannot be re-used, it should be disposed of in accordance with EU and local regulations.</p>
--	--

 DANGER	<p>Do not throw away the waste oil of the compressor, because it contains refrigerant in solution.</p> <p>The waste oil should be disposed of in accordance with EU and local regulations.</p>
--	--

Unless otherwise specified, the operations described below may be carried out only by a trained maintenance operator.

9.1 General requirements

Units have been designed for continuous operation, providing that they are subjected to regular maintenance within the limits specified in this manual. Each unit must be serviced according to the programme by the User/Customer, and must be inspected at regular intervals by the personnel of an Authorised Service Centre.

It is the responsibility of the User to meet these maintenance requirements and/or to enter into an agreement with an Authorised Service Centre, to properly safeguard the operation of the appliance.

During the warranty period, in case of damage or failures caused by improper maintenance, the manufacturer will not refund the costs incurred to repair the appliance in its original state.

The provisions of this section apply only to standard units; according to the order requirements, other documentation may be added, concerning any modifications or supplementary accessories.

9.2 Planned maintenance

Maintenance inspections must be carried out according to the program shown right, by a qualified person.

As a general rule, units cannot be repaired directly by the user, who shall not try to service or repair any failures or anomalies identified during daily inspections. If you are in doubt, please contact an Authorised Service Centre.

Operations	Daily	Weekly	Monthly	Beginning of season	End of season
Check the temperature of the leaving fluid	•				
Check the pressure drops in the heat exchanger		•			
Check for electric absorption		•			
Check suction pressure and temperature		•			
Check delivery pressure and temperature		•			
Check the oil level in the compressor		•			
Check that there are no gas bubbles in the liquid line		•			
Check the operation of the oil heaters			•		
Check the remote control switches			•		
Check the operation of the SP pressure switch				•	
Check the operation of the HP pressure switch				•	
Check the insulation of the heat exchanger				•	
Check that terminals are tightened				•	
Check that the terminals' screws are tightened				•	
Clean the exterior of the unit with water and soap				•	
Check the density of the antifreeze (if any)				•	•
Check the operation of differential pressure / flow switches				•	
Check the operation of the solenoid valve				•	•

9 - Maintenance (continued)

9.3 Refrigerant charge

Do not inject refrigerant liquid into the SP side of the circuit. Be very careful, and charge the circuit properly. If the charge is insufficient, the efficiency of the unit will be lower than expected. (In the worst case the SP transducer may stop the unit.)

In the presence of an excess charge, the condensing pressure will rise (in the worst case, the HP pressure switch may be activated, resulting in the equipment stopping), the consumption will also increase.

It is strictly forbidden to use the compressor as a vacuum pump to drain the plant.

Fill the refrigeration circuit after it has been drained for maintenance purposes (leaks, replacement of the compressor etc.). The charge amount is indicated on the plate affixed to the unit.

Before refilling, it is important to drain and de-hydrate the circuit, thus obtaining a minimum abs. pressure value of 50 Pa.

Inject the refrigerant fluid before removing the vacuum, then fill the circuit up to 90% of the total gas requirement (in liquid form). The appliance must be filled through the filling valve on the liquid line, on the outlet side of the condenser.

It is recommended to connect the refrigerant cylinder to the filling valve on the liquid line, and to arrange it in such a way as to inject only liquid refrigerant.

9.4 Compressor

Compressors are delivered with the necessary charge of lubricating oil. During normal operation, this charge is sufficient for the whole life of the unit, providing that the efficiency of the refrigeration circuit is satisfactory and if it has not been overhauled.

If the compressor needs to be replaced (following a mechanical failure or if burnt), contact an Authorised Service Centre.

Compressors use polyester oil. During maintenance operations on the compressor, or if you have to open the refrigerant circuit in any point, remember that this type of oil is highly hygroscopic, and accordingly it is important that it is not left exposed to atmosphere for prolonged periods, as this would require the replacement of the oil.

9.5 Condenser

Check at regular intervals that the water side of the heat exchanger is perfectly clean. To do this, measure the pressure drop, water side (see Section "8 - Technical Data") or measure the temperature of the liquid leaving and entering the heat exchanger, and compare it to the condensing temperature.

To obtain an effective heat exchange, the difference between the temperature of the leaving water and the saturated condensing temperature must be in the 3 - 5°C range. A greater difference would indicate a low efficiency of the heat exchanger (i.e. the heat exchanger is dirty).

In this case, the heat exchanger must be subjected to chemical cleaning, an operation that shall be carried out by authorised engineers.

For other maintenance operations (extraordinary overhauling, replacement of the heat exchanger etc.), contact an Authorised Service Centre.

9.6 Dehydrating filter

The refrigeration circuits are provided with dehydrating filters.

Filter clogging is marked by the presence of air bubbles in the sight glass, or by the difference between the temperatures measured from downstream and upstream of the drying filter. If, once the cartridge has been cleaned, there are still some air bubbles, the appliance has lost a part of the refrigerant charge in one or more points, that must be identified and serviced.

9.7 Sight glass

The sight glass is used for inspecting the refrigerant flow and the humidity % of the refrigerant. The presence of bubbles indicates that the dehydrating filter is clogged or insufficient refrigerant charge.

A colour indicator is positioned inside the sight glass. If you compare the colour of the indicator to the scale on the ring of the sight glass, you can calculate the percentage of humidity of the refrigerant. If it is excessive, replace the filter cartridge, operate the appliance for 1 day and then check the humidity % again. When the humidity % is within the pre-determined range, no other operations are required. If the humidity % is still too high, replace the dehydrating filter again, start the unit and operate it for another day, repeating the humidity % check after the test run.

9 - Maintenance (continued)

9.8 Mechanical expansion valve

The refrigerant circuit of the unit is equipped with a mechanical expansion valve, with external equaliser.

The valve is factory calibrated for an overheating of 5 °C.

Procedure to check for overheating:

- Measure the suction pressure with the pressure gauges on the board of the unit using a pressure gauge connected to the service valve on the suction side.
- From the pressure gauge's temperature scale, measure the saturated suction temperature (T_{sa}) which corresponds to the pressure value.
- Using a contact pressure gauge affixed to the gas outlet fitting of the evaporator, measure the actual temperature (T_{se}).

Overheating calculation (SH):

$$SH = T_{se} - T_{sa}$$

Overheating is regulated through the expansion valve.

Make a complete turn of the adjusting screw and operate the appliance for five minutes.

Check again and, if necessary, repeat the regulation.

If the expansion valve cannot be regulated, it is probably broken, and must be replaced. The replacement must be carried out by an Authorised Service Centre.

9.9 Evaporator

Check at regular intervals that the water side of the heat exchanger is perfectly clean. To do this, measure the pressure drop, water side (see Section "8 - Technical Data") or measure the temperature of the liquid leaving and entering the heat exchanger, and compare it to the evaporation temperature.

To obtain an effective heat exchange, the difference between the temperature of the leaving water and the saturated evaporating temperature must be in the 2 - 4°C range. A greater difference would indicate a low efficiency of the heat exchanger (i.e. the heat exchanger is dirty).

In this case, the heat exchanger must be subjected to chemical cleaning, an operation that shall be carried out by authorised engineers.

For other maintenance operations (extraordinary overhauling, replacement of the heat exchanger etc.), contact an Authorised Service Centre.

10 - Troubleshooting

The table below lists the anomalies of operation of the unit, the relevant causes and the corrective measures. For anomalies of any other type or not listed, contact an Authorised Service Centre for technical assistance.

Anomaly	Cause	Operation
The unit continues to work, but without cooling	Insufficient charge of refrigerant.	Refill.
	The dehydrating filter is clogged.	Replace.
Ice on the suction line	Wrong calibration of overheating.	Increase overheating.
		Check the charge.
Excessive noise	Vibration of lines.	Check the clamping brackets, if any.
	Whistle emitted by the thermostatic expansion valve.	Refill.
		Check the dehydrating filter.
	Noisy compressor.	Seized bearings; replace the compressor.
Check that the compressor's locknuts are tightened.		
Low oil level in the compressor	One or more gas or oil leaks in the circuit.	Identify and remove leaks.
	Mechanical failure of the compressor.	Request the intervention of an Authorised Service Centre.
	Compressor base pan oil heater anomaly.	Check the electric circuit and the resistor of the heater of the motor base, and replace defective components.
One or both compressors are not working	Circuit breaker activation.	Check the electric circuit and detect any ground dispersions and short circuits. Check fuses.
	Intervention of the HP pressure switch.	Reset the pressure switch and the control panel and restart the appliance. Identify and remove the cause that enabled the pressure switch.
	The fuse of the control circuit is broken.	Check for ground dispersions and short circuits. Replace fuses.
	Loosened terminals.	Check and tighten.
	Halt caused by thermal overload of the electric circuit.	Check the operation of check / safety devices. Identify and remove the cause.
	Wrong wiring.	Check wiring of check / safety devices.
	The line voltage is too low.	Check voltage. If problems regard the system, solve them. If they are caused by the distribution network, inform the Energy Distributor.
	Short-circuit of the compressor's motor.	Check the continuity of the winding.
	Seized compressor.	Replace the compressor.
Activation of the SP alarm, stop of the unit	Gas leak.	Identify and remove the leak.
	Insufficient charge.	Refill.
	Failure of the pressure switch.	Replace the pressure switch.
	Evaporator pump has stopped.	Check cables and motor. If defective, repair or replace.
Activation of the HP alarm, stop of the unit	Failure of the pressure switch.	Check the operation of the pressure switch, replace it if defective.
	The delivery valve is partially closed.	Open the valve and replace it, if faulty.
	Condenser pump has stopped.	Check cables and motor. If defective, repair or replace.
The liquid line is too hot	Insufficient charge.	Identify and remove the cause of the loss of charge and refill.
Frosting of the liquid line	The valve of the liquid line is partially closed.	Check that valves are open.
	The liquid filter is clogged.	Replace the cartridge or the filter.

11 - Spare Parts

11.1 Spare part list

The table below shows the list of spare parts recommended during the first two years of operation.

Component	Number
Pump	1
Differential pressure switch	1
High pressure transducer	1
Low pressure transducer	1
Expansion valve	1
Gas filter	1
4 way valve	1
Electronic main board	1
Auxiliary circuit transformer	1
Compressor contactor	2
Pump contactor	1
Water sensor	4
Auxiliary contact	4
Driver EEV	1
Fuses	4

11.2 Oil for compressors

The compressors are lubricated with polyester oil (P.O.E.).

11.3 Wiring diagrams

The wiring diagrams are installed inside the doors of the electrical panels of the unit. Any request for wiring diagrams shall be forwarded to manufacturer's Service Centre.

12 - Disassembly, recycling and/or disposal at end-of-life



During the draining of the refrigeration circuits, do not let the refrigerant overflow in the surrounding atmosphere.

The circuit must be drained using suitable recovery equipment.



Do not disperse the waste oil of the compressors in the environment, since it contains some dissolved refrigerant.

For the disposal, contact the competent authority for information.

Unless otherwise specified, the disassembly, recycling and/or disposal operations listed below may be carried out by any trained maintenance operator.

12.1 Generalities

Isolate each line that supplies the unit, including the ones of control circuits. Make sure that all disconnecting switches are secured in the off position. The power cables can be disconnected and disassembled. Refer to Chapter "4 - Installation" for the position of connection points.

Remove all the refrigerant from the refrigerant circuits of the unit and store it in suitable containers, using a recovery unit. If its characteristics have remained the same, the refrigerant may be recycled and used again. Contact the competent authority to obtain information about disposal. In **NO** event shall the refrigerant be discharged into the atmosphere. The oil in each refrigeration circuit must be drained and collected into a suitable container; then it shall be disposed of in conformity with local regulations that apply to the disposal of waste lubricants. Any oil spillage must be recovered and disposed of in a like manner.

Isolate the unit's heat exchangers from the external hydraulic circuits and drain the heat exchange sections of the plant.



If no shutoff valves have been provided, it may be necessary to drain the whole plant.

If a glycoled solution or a similar fluid has been used in the hydraulic circuits, or if chemical additives have been added to the circulating water, the circulating fluid MUST be drained in a proper way.

For NO reason shall a circuit containing glycoled water or a similar solution be discharged directly into the drains or surface waters.

After draining operations, the piping of the hydraulic networks can be disconnected and disassembled.

Once they have been disconnected as specified, the packaged units can be disassembled in a single piece. First of all, disassemble the anchoring screws and then lift the unit from the position of installation, and hook it to the lifting points provided, using suitable lifting equipment.

To this end, refer to Chapter "4 - Installation" for the installation of these appliances, to Chapter "8 - Technical Data" for their weights and Chapter "3 - Transport, Lifting and Positioning" for handling.

The units that, once disconnected, cannot be removed in a single piece, must be dismantled on site; in this case, be very careful with the weight and handling of every single component.

It is always advisable to dismantle the units following the installation steps, but in reverse.



Some residues of oil, glycoled water or similar solutions may remain in certain parts of the unit. These residues must be recovered and disposed of according to the procedures specified above.

It is very important to ensure that, while a component of the unit is being removed, all the others are properly supported.



Use only lifting means of adequate capacity.

Once disassembled, the components of the unit can be disposed of in conformity with current regulations.

12.2 WEEE Directive (only EU)



- The WEEE Directive requires that the disposal and recycling of electrical and electronic equipment must be handled through a special collection, in appropriate centres, separate from that used for the disposal of mixed urban waste.
- The user has the obligation not to dispose of the equipment at the end of the useful life as municipal waste, but to send it to a special collection centre.
- The units covered by the WEEE Directive are marked with the symbol shown above.
- The potential effects on the environment and human health are detailed in this manual.

Panasonic Heating & Ventilation Air-Conditioning Italy
Via XXV Aprile, 29
20825 Barlassina (MB) Italy

Tel. +39 0362 680 1
Fax +39 0362 680 693

www.aircon.panasonic.eu

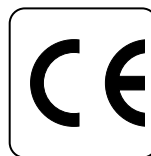

As part of our ongoing product improvement programme, our products are subject to change without prior notice. Non contractual photos.

